

NOTICE OF DECISION
MYRTLEWOOD SUBDIVISION TENTATIVE PLAN – SUB221-0002

December 9, 2021

Nick Daniken
16869 SW 65th Ave Suite 115,
Lake Oswego, OR 97035

The Newberg Community Development Director has approved the proposed tentative plan SUB221-0002 for a ten (10) lot subdivision for the Myrtlewood Subdivision, tax lot R320703202 subject to the conditions listed in the attached report. The decision will become final on December 23, 2021, unless an appeal is filed.

All persons entitled to notice or anyone providing written comments within 14 calendar days prior to the date of the decision may appeal this decision to the Newberg Planning Commission in accordance with Newberg Development Code 15.100.170. All appeals must be in writing on a form provided by the Planning Division. Anyone wishing to appeal must submit the written appeal form together with the required fee of \$550.20 to the Planning Division within 14 days of the date of this decision.

The deadline for filing an appeal is 4:30 pm on December 22, 2021.

At the conclusion of the appeal period, please remove all notices from the site.

In order to fully complete the subdivision process, the applicant must meet all conditions of tentative plan approval and file a final subdivision plat application with the Planning Division. The final subdivision plat must be recorded within two years of the effective date noted above. If you are approaching the expiration date, please contact the Planning Division regarding extension opportunities.

If you have any questions; please contact me at doug.rux@newbergoregon.gov or 503.537.1212.

Sincerely,

A handwritten signature in blue ink, appearing to read "Doug Rux".

Doug Rux, AICP
Community Development Director

cc: file SUB221-0002

DECISION AND FINDINGS
MYRTLEWOOD SUBDIVISION TENTATIVE PLAN SUB221-002

FILE NO: SUB221-0002
 REQUEST: Subdivide a 76,006 square foot property into 10 lots for single-family homes.
 LOCATION: 2900 Crater Ln.
 TAX LOT(S): Tax Map R3207; Tax Lot 03202
 APPLICANT: Nick Daniken, Greenwing Restorations, LLC
 OWNER: Greenwing Restorations, LLC
 ZONE: Low Density Residential District (R-1)
 PLAN DISTRICT: LDR Low Density Residential



- CONTENTS**
 Section I: Application Information
 Section II: Findings
 Section III: Conditions
 Attachments:
 1. Agency Comments
 2. Preliminary Plat
 4. Application

A. APPLICATION: The applicant, Nick Daniken , has requested a tentative plan approval for Myrtlewood Subdivision file number SUB221-0002. The applicant has proposed a 10-lot subdivision of Yamhill County Tax Lot, R3207 03202. The property is approximately 1.74 acres. Lot sizes will range from 5,000 square feet to 6,952 square feet. The average lot size in the subdivision is 5,664 square feet. Access to the subdivided lot will be provided from W Myrtlewood Drive and N Crater Lane, which both have functional classifications as Local Residential Streets in the Newberg Transportation System Plan (TSP). An extension of W Myrtlewood Drive through the site will be constructed along with frontage improvements on N Crater Lane. Each lot with street frontage has a utility easement. Lots with direct frontage on W Myrtlewood Drive will have access easements to provide access to the back lots. One lot will take access from N Crater Lane.

B. SITE INFORMATION:

Location: 2900 N Crater Lane

Size: 1.74 acres

Topography: There is a slight grade change of 8 feet across the property from the southwest corner of the site to the northeast corner, with the highest point at the northeast corner. A steep slope abuts the south property line where a drainage ditch exists.

Current Land Uses: Vacant

Natural Features: Groundcover and trees along the edge of the property.

Adjacent Land Uses:

North: Single-family homes

East: Single-family homes

South: Single-family homes

West: Single-family homes

Surrounding Zoning:

North: R-1 (Low Density Residential)

East: R-1 (Low Density Residential)

South: R-1 (Low Density Residential)

West: R-1 (Low Density Residential)

Access and Transportation: Access to the proposed subdivision is provided from the newly proposed street improvement connecting W Myrtlewood Drive to the east N Crater Lan on the west. W Myrtlewood Drive currently terminates on the east side of the site. The applicant will complete a full build-out of the W Myrtlewood Drive extension built to the standards for a local road, consistent with the Transportation System Plan. Nine of

the ten lots in the subdivision will take access from W Myrtlewood Drive. Four of the lots will have access through the shared access easement, Lots 3, 4, 8, and 9. Lot 1 will take access from N Crater Lane. Where the site abuts N Crater Lane a 10-foot-wide right-of-way dedication will be provided.

Water: There are existing 8-inch water lines along W Myrtlewood Drive east and west of the property and a 10-inch water line in N Crater Lane to the west of the site.

Wastewater: There is an existing 8-inch public wastewater line in N Crater Lane to the west of the site and an 8-inch wastewater line terminating in a manhole in W Myrtlewood Drive to the east of the site. There is also a 12-inch public force main on the southern border of the site.

Stormwater: Storm systems exist immediately south of the property, and east and west of the property along W Myrtlewood Drive. There is a 12-inch storm line with an inlet on the east boundary of the site where W Myrtlewood Drive is stubbed. There is a drainage ditch/creek that runs along the east and south boundaries of the site. The alignment of this open drainage crosses onto properties to the south. The applicant submitted a report by PHS which delineated the drainage ditch as a “water of the state” tributary to Chehalem Creek. Daniel Evans, a Division of State Lands (DSL) representative emailed on November 5, 2021, stating that “DSL is presuming jurisdiction on Tributary A.” There is a 15-inch storm line that appears to drain a large area south of the site into the drainage ditch (Tributary A) at the southern boundary of the site. There is a large area northeast of the site that also drains to the drainage ditch/creek. The drainage ditch flows under N Crater Lane in a group of culverts.

Overhead Lines: There are no overhead utilities serving the property or running parallel to the property frontage. Any new connection the property will need to be undergrounded. See NMC 15.430.010 for exception provisions.

- C. PROCESS:** The subdivision request is a Type II application and follows the procedures in Newberg Development Code 15.100.030. Following a 14-day public comment period, the Community Development Director decides on the application based on the criteria listed in the attached findings. The Community Development Director’s decision is final unless appealed. Important dates related to this application are as follows:

10/11/21: The Community Development Director deemed the application complete.

10/14/21: The applicant mailed notice to the property owners within 500 feet of the site.

10/14/21: The applicant posted notice on the site.

10/27/21: The 14-day public comment period ended.

11/26/21: The Community Development Director issued a decision on the application.

D. AGENCY COMMENTS: The application was routed to several public agencies for review and comment. Comments and recommendations from city departments have been incorporated into the findings and conditions. As of the writing of this report, the city received the following agency comments:

Building: Reviewed; no conflict.

Finance: Reviewed; no conflict.

Police Department: Reviewed; no conflict.

Public Works Maintenance: Reviewed; Comments incorporated into the decision.

Ziply Fiber: Reviewed; no conflict.

TVF&R: Comments, see attached.

Department of State Lands: Comments, see attached.

E. PUBLIC COMMENTS:

No public comments were received.

F. ANALYSIS:

Street Improvements: The applicant is proposing to extend W Myrtlewood Drive to complete the connection of W Myrtlewood Drive to N Crater Lane and N Main Street. They are proposing a full-street improvement and dedicating 54-feet of right-of-way. To meet the minimum requirements for a local residential street 56-feet of right-of-way is required. Ten feet of right-of-way on N Crater Lane will also be dedicated and frontage improvements will be completed.

Access: Lot 1 will take access from N Crater Lane. Lot 2 abuts N Crater Lane and W Myrtlewood Drive, and can take access on either frontage, but not both. The remaining lots will take access from W Myrtlewood Drive. Shared access easements will provide the access for lots that do not abut W Myrtlewood Drive. A 25-foot-wide shared access and utility easement will be provided on Lots 3 and 6 to serve Lots 4 and 5. Additionally, a 25-foot-wide shared access and utility easement will be provided on Lots 7 and 10 to serve Lots 8 and 9.

Stormwater Management: A preliminary stormwater report has been submitted in the application. The applicant is proposing to maintain a tract for on-site stormwater

management for the subdivision (see Tract A). Additionally, the applicant is proposing to replace the existing ditch located along the south and east property lines with a 42-inch stormwater pipeline.

Section II: Findings –File SUB221-0002 Myrtlewood Subdivision

II. Applicable Land Division Standards and Criteria

15.235.050 Preliminary plat approval criteria.

A. Approval Criteria. By means of a Type II procedure for a partition, or a Type II or III procedure for a subdivision per NMC 15.235.030(A), the applicable review body shall approve, approve with conditions, or deny an application for a preliminary plat. The decision shall be based on findings of compliance with all of the following approval criteria:

1. The land division application shall conform to the requirements of this chapter;

Finding: The application includes all of the required submittal elements and follows the proper process and public notice requirements for a subdivision.

2. All proposed lots, blocks, and proposed land uses shall conform to the applicable provisions of NMC Division 15.400, Development Standards;

Finding: Compliance with provisions of NMC 15.400, Development Standards, are addressed below.

15.405.010 Lot area – Lot areas per dwelling unit

A. In the following districts, each lot or development site shall have an area as shown below except as otherwise permitted by this code:

1. In the R-1 district, each lot or development site shall have a minimum area of 5,000 square feet or as may be established by a subdistrict. The average size of lots in a subdivision intended for single-family or duplex dwelling development shall not exceed 10,000 square feet.

B. Lot or Development Site Area per Dwelling Unit.

1. In the R-1 district, there shall be a minimum of 5,000 square feet per dwelling unit, except that there shall be a minimum of 5,000 square feet per duplex dwelling.

Finding: The applicant has chosen to comply with lot size standard by averaging lot sizes. As described below, the average lot size per dwelling in the subdivision is 5,023 square feet. The standards are met.

C. In calculating lot area for this section, lot area does not include land within public or private streets. In calculating lot area for maximum lot area/minimum density requirements, lot area does not include land within stream corridors, land reserved for public parks or open spaces, commons buildings, land for preservation of natural, scenic, or historic resources, land on slopes exceeding 15 percent or for avoidance of identified natural hazards, land in shared access easements, public walkways, or entirely used for utilities, land held in reserve in accordance with a future development plan, or land for uses not appurtenant to the residence.

D. Lot size averaging is allowed for any subdivision. Some lots may be under the minimum lot size required in the zone where the subdivision is located, as long as the average size of all lots is at least the minimum lot size.

Finding: The lot sizes of each lot in the subdivision, are as follows:

- Lot 1: 5,001 sq. ft.,
- Lot 2: 5,000 sq. ft.,
- Lot 3: 5,000 sq. ft.,
- Lot 4: 5,003 sq. ft.,
- Lot 5: 5,000 sq. ft.,
- Lot 6: 5,000 sq. ft.,
- Lot 7: 6,952 sq. ft.,
- Lot 8: 6,468 sq. ft.,
- Lot 9: 6,472 sq. ft., and
- Lot 10: 6,747 sq. ft.,

The average lot size in the subdivision is 5,664 square feet. Therefore, the average is above the minimum lot size permitted by the zone and the standard is met.

Through lot size averaging in the subdivision, the lot area requirements for the zone are met.

15.405.030 Lot Dimensions and Frontage

A. Width. Widths of lots shall conform to the standards of this code.

B. Depth to Width Ratio. Each lot and parcel shall have an average depth between the front and rear lines of not more than two and one-half times the average width between the side lines. Depths of lots shall conform to the standards of this code. Development of lots under 15,000 square feet are exempt from the lot depth to width ratio requirement.

Finding: The proposed lots are under 15,000 square feet.

This standard does not apply.

C. Area. Lot sizes shall conform to standards set forth in this code. Lot area calculations shall not include area contained in public or private streets as defined by this code.

Finding: The proposed lots conform to the lot area requirements for subdivisions in the R-1 zone.

The standard is met.

D. Frontage.

1. No lot or development site shall have less than the following lot frontage standards:

a. Each lot or development site shall have either frontage on a public street for a distance of at least 25 feet or have access to a public street through an easement that is at least 25 feet wide. No new private streets, as defined in NMC 15.05.030, shall be created to provide frontage or access except as allowed by NMC 15.240.020(L)(2).

Finding: All lots except Lot 1 will have access to W Myrtlewood Drive. Lots 4, 5, 8, and 9 will have access to W Myrtlewood Drive by shared access easements. Lot 1 will take access from N Crater Lane. Each shared access easement, providing access to two lots, is 25 feet wide. Lot 8 and 9 are served by a 25-foot-wide access easement. The same is true for Lots 4 and 5. The access easements are not a Private Street as defined by the NMC 15.05.030.

c. Each lot in R-1 zone shall have a minimum width of 35 feet at the front building line and AI or RP shall have a minimum width of 50 feet at the front building line.

Finding: Building locations are not proposed as a part of this subdivision plat application. All proposed lot widths are well more than 35 feet. The standard is met.

15.405.040 Lot coverage and parking coverage requirements.

Finding: This section of the NDC will be reviewed, if applicable, during the building permit review process. This section is not applicable at this stage of the subdivision review process because it is more appropriately reviewed during the building permit review process.

15.410.010 General yard regulations.

Finding: This section of the NDC will be reviewed, if applicable, during the building permit review process. This section is not applicable at this stage of the subdivision review process because it is more appropriately reviewed during the building permit review process.

15.410.060 Vision clearance setback.

The following vision clearance standards shall apply in all zones (see Appendix A, Figure 9).

B. At the intersection of a private drive and a street, a triangle formed by the intersection of the curb lines, each leg of the vision clearance triangle shall be a minimum of 25 feet in length.

C. Vision clearance triangles shall be kept free of all visual obstructions from two and one-half feet to nine feet above the curb line. Where curbs are absent, the edge of the asphalt or future curb location shall be used as a guide, whichever provides the greatest amount of vision clearance.

Finding: A 25-foot-long vision clearance triangle is required at the entrances to the shared access easements between Lots 3, 6, 7 and 10 and at the intersection of N Crater Lane and W Myrtlewood Drive. Future development on the proposed lots will be required to demonstrate vision clearance triangles on plans and keep them clear of all visual obstructions pursuant to this standard.

This criterion will be met if the aforementioned condition of approval is adhered to.

15.430.010 Underground utility installation.

A. All new utility lines, including but not limited to electric, communication, natural gas, and cable television transmission lines, shall be placed underground. This does not include surface-mounted transformers, connections boxes, meter cabinets, service cabinets, temporary facilities during construction, and high-capacity electric lines operating at 50,000 volts or above.

B. Existing utility lines shall be placed underground when they are relocated, or when an addition or remodel requiring a Type II design review is proposed, or when a developed area is annexed to the city.

C. The director may make exceptions to the requirement to underground utilities based on one or more of the following criteria:

- 1. The cost of undergrounding the utility is extraordinarily expensive.*
- 2. There are physical factors that make undergrounding extraordinarily difficult.*
- 3. Existing utility facilities in the area are primarily overhead and are unlikely to be changed.*

Finding: The proposed project narrative describes the utilities installed underground. This criterion is met.

Chapter 15.440 Off-Street Parking, Bicycle Parking, and Private Walkways

15.440.030 Parking Space Required

<i>Use</i>	<i>Minimum Parking Spaces Required</i>
<i>Residential Types</i>	
<i>Dwelling, single-family or two-family</i>	<i>2 for each dwelling unit on a single lot</i>

Finding: The applicant’s narrative states the proposed lots sizes will easily accommodate two car garages, as well as driveways capable of parking two (2) vehicles. Homes with more than four bedrooms are not anticipated for this subdivision. Ultimate compliance with the off- street parking requirements will be reviewed during the building permit process. This proposal satisfied the criteria.

15.440.060 Parking area and service drive improvements.

All public or private parking areas, outdoor vehicle sales areas, and service drives shall be improved according to the following:

G. Parking areas for residential uses shall not be located in a required front yard, except as follows:

1. Attached or detached single-family or two-family: parking is authorized in a front yard on a service drive which provides access to an improved parking area outside the front yard.

Finding: This section of the NDC will be reviewed, if applicable, during the building permit review process. This section is not applicable at this stage of the subdivision review process because it is more appropriately reviewed during the building permit review process.

15.235.050(A) Preliminary plat approval criteria (continued).

3. Access to individual lots, and public improvements necessary to serve the development, including but not limited to water, wastewater, stormwater, and streets, shall conform to NMC Division 15.500, Public Improvement Standards;

Chapter 15.505 Public Improvements Standards

15.505.020 Applicability.

The provision and utilization of public facilities and services within the City of Newberg shall apply to all land developments in accordance with this chapter. No development shall be approved unless the following improvements are provided for prior to occupancy or operation, unless future provision is assured in accordance with NMC 15.505.030(E).

A. Public Works Design and Construction Standards. The design and construction of all improvements within existing and proposed rights-of-way and easements, all improvements to be maintained by the city, and all improvements for which city approval is required shall comply with the requirements of the most recently adopted Newberg public works design and construction standards.

B. Street Improvements. All projects subject to a Type II design review, partition, or subdivision approval must construct street improvements necessary to serve the development.

Finding: The applicant's preliminary plans show installing an extension of W Myrtlewood Drive from N Crater Lane to W Myrtlewood Drive which is stubbed to the east boundary of the project site. Additionally, the proposed plan shows sidewalk and street improvements along the frontage adjacent to N Crater Lane.

These criteria will be met if all improvements necessary to serve the development meet City standards and are completed, see conditions in Section 15.505.030.

C. Water. All developments, lots, and parcels within the City of Newberg shall be served by the municipal water system as specified in Chapter 13.15 NMC.

Finding: Preliminary plans show a new water line in the extension of W Myrtlewood Drive connecting to the existing waterline in W Myrtlewood Drive and the existing water line in N Crater Lane. No size is given. Because the applicant has not submitted construction plans, plans for water system improvements meeting requirements of the Newberg Public Works Design and Construction Standards shall be submitted with the public improvement permit application. This criterion will be met if all improvements necessary to service the development meet City standards and are completed, see conditions in Section 15.505.040(D).

This criterion will be met if the aforementioned condition of approval is adhered to.

D. Wastewater. All developments, lots, and parcels within the City of Newberg shall be served by the municipal wastewater system as specified in Chapter 13.10 NMC.

Finding: Preliminary plans show a new wastewater line installed in the proposed extension of W Myrtlewood Drive. The proposed wastewater line is shown connecting to an existing wastewater line in N Crater Lane. The size of the proposed line is not shown. The plans do show wastewater

service extended in the shared driveways serving lots 8 & 9 and 5 & 4. Each set of lots on the shared driveways is shown served by one connection to the public line. Each lot will need its own connection to the public line. Because the applicant has not submitted construction plans, plans for wastewater system improvements meeting requirements of the Newberg Public Works Design and Construction Standards to be submitted with the public improvement permit application. Plans to include the size of the proposed wastewater line and individual services to lots 8, 9, 5, and 4. This criterion will be met if all wastewater improvements necessary to service the development meet City standards and are completed, see conditions in Section 15.505.040(E).

This criterion will be met if the aforementioned condition of approval is adhered to.

E. Stormwater. All developments, lots, and parcels within the City of Newberg shall manage stormwater runoff as specified in Chapters 13.20 and 13.25 NMC.

Finding: The proposed development will create more than 500 square feet of impervious area, public and private. The applicant proposes to treat and detain stormwater in a facility in Tract A. Lots 3,4,5,6,7,8,9, and 10 are shown connected to the stormwater line draining to the facility in Tract A. Lot 2 is shown connected to the storm line leaving the facility in Tract A and connecting to a storm line across N Crater Lane in the existing W Myrtlewood Drive. Lot 1 drains to a 42-inch storm line proposed along the southern boundary of the site to replace an existing drainage ditch. The drainage ditch is delineated as Tributary A, a “water of the state” tributary to Chehalem Creek, by Pacific Habitat Services, Inc. in their “Wetland delineation for 2900 Crater Lane August 2021” report which was submitted with the application. Daniel Evans, a Division of State Lands (DSL) representative emailed on November 5, 2021, stating that “DSL is presuming jurisdiction on Tributary A.” The applicant will be required to submit copies of any federal and/or state permits necessary to replace Tributary A with a storm collection pipe or provide documentation from federal and state agencies that no permits are required. This documentation of federal and/or state permitting is to be submitted with the public improvement permit application. Plans for stormwater system improvements meeting requirements of the Newberg Public Works Design and Construction Standards shall be submitted with the public improvement permit application. This criterion will be met if all stormwater improvements necessary to service the development meet City standards and are completed, see conditions in Section 15.505.050.

This criterion will be met if the aforementioned condition of approval is adhered to.

F. Utility Easements. Utility easements shall be provided as necessary and required by the review body to provide needed facilities for present or future development of the area.

Finding: The applicant’s preliminary plans show 8-foot-wide public utility easements along the frontages of lots on the proposed extension of W Myrtlewood Drive. These public utility easements are to be 10-feet wide. Because the applicant has not submitted construction plans, final plans showing the public utility easements as 10-feet wide will be required to be submitted

with the public improvement permit application. This criterion will be met if all easements necessary to service the development meet City standards and are completed, see conditions in Section 15.505.040(F).

This criterion will be met if the aforementioned condition of approval is adhered to.

G. City Approval of Public Improvements Required. No building permit may be issued until all required public facility improvements are in place and approved by the director, or are otherwise bonded for in a manner approved by the review authority, in conformance with the provisions of this code and the Newberg Public Works Design and Construction Standards.

Finding: A building permit will not be issued until the public facility improvements required in the conditions are in place and meet the Newberg Public Works Design and Construction Standards.

15.505.030 Street standards.

C. Layout of Streets, Alleys, Bikeways, and Walkways. Streets, alleys, bikeways, and walkways shall be laid out and constructed as shown in the Newberg transportation system plan. In areas where the transportation system plan or future street plans do not show specific transportation improvements, roads and streets shall be laid out so as to conform to previously approved subdivisions, partitions, and other developments for adjoining properties, unless it is found in the public interest to modify these patterns. Transportation improvements shall conform to the standards within the Newberg Municipal Code, the Newberg public works design and construction standards, the Newberg transportation system plan, and other adopted city plans.

D. Construction of New Streets. Where new streets are necessary to serve a new development, subdivision, or partition, right-of-way dedication and full street improvements shall be required. Three-quarter streets may be approved in lieu of full street improvements when the city finds it to be practical to require the completion of the other one-quarter street improvement when the adjoining property is developed; in such cases, three-quarter street improvements may be allowed by the city only where all of the following criteria are met:

- 1. The land abutting the opposite side of the new street is undeveloped and not part of the new development; and***
- 2. The adjoining land abutting the opposite side of the street is within the city limits and the urban growth boundary.***

Finding: W Myrtlewood Drive is designated as a “local residential” street. As part of the subdivision, the applicant is proposing to extend W Myrtlewood Drive through the site in a 54-foot-wide right-of-way, with a curb-to-curb pavement width of 34 ½ feet. The proposed

extension of W Myrtlewood Drive will require 56 feet of right-of-way. The cross section will reflect the City’s Transportation System Plan and Public Works Design and Construction Standards for a “local residential” street if it includes:

- 1-foot from back of walk to right-of-way
- 5-foot sidewalk
- 5.5-foot planter
- 0.5-foot curb
- 7-foot parking lane
- 9-foot drive lane
- 9-foot drive lane
- 7-foot parking lane
- 0.5-foot curb
- 5.5-foot planter
- 5-foot sidewalk
- 1-foot from back of walk to right-of-way

Because final construction plans have not been submitted, plans describing a 56-foot right-of-way for W Myrtlewood Drive with a cross section design matching the City’s Transportation System Plan and Public Works Design and Construction Standards for a “local residential” street shall be submitted with the public improvement permit application. This criterion will be met if all improvements necessary to serve the development meet City standards and are completed, see conditions in Section 15.505.030.

This criterion will be met if the aforementioned condition of approval is adhered to.

E. Improvements to Existing Streets.

1. All projects subject to partition, subdivision, or Type II design review approval shall dedicate right-of-way sufficient to improve the street to the width specified in subsection (G) of this section.

Finding: The Applicant is proposing a 10-foot right-of-way dedication along the site’s N Crater Lane frontage. This will increase the N Crater Lane right-of-way to 30 feet adjacent to the site

matching the right-of-way width south of the site and consistent with the right-of-way width of most of N Crater Lane between W Mountainview Drive and W Foothills Drive. The 10-foot right-of-way dedication along the site's N Crater Lane frontage shall be shown on construction plans and on the final plat.

This criterion will be met if the aforementioned condition of approval is adhered to.

2. All projects subject to partition, subdivision, or Type II design review approval must construct a minimum of a three-quarter street improvement to all existing streets adjacent to, within, or necessary to serve the development. The director may waive or modify this requirement where the applicant demonstrates that the condition of existing streets to serve the development meets city standards and is in satisfactory condition to handle the projected traffic loads from the development. Where a development has frontage on both sides of an existing street, full street improvements are required.

Finding: The Applicant is proposing improvements to N Crater Land to include 9 feet of pavement to provide a 16-foot-wide travel lane, sidewalks, planter strip and curb and gutter. Because final construction plans have not been submitted, final plans of the proposed N Crater Lane street improvements will need to be submitted with the public improvement permit application. This criterion will be met if all improvements necessary to serve the development meet City standards and are completed.

This criterion will be met if the aforementioned condition of approval is adhered to.

3. In lieu of the street improvement requirements outlined in NMC 15.505.040(B), the review authority may elect to accept from the applicant monies to be placed in a fund dedicated to the future reconstruction of the subject street(s). The amount of money deposited with the city shall be 100 percent of the estimated cost of the required street improvements (including any associated utility improvements), and 10 percent of the estimated cost for inflation. Cost estimates used for this purpose shall be based on preliminary design of the constructed street provided by the applicant's engineer and shall be approved by the director.

Finding: The applicant is proposing complete build-out of required improvements. No fee-in-lieu is proposed. The standard is not applicable.

F. Improvements Relating to Impacts. Improvements required as a condition of development approval shall be roughly proportional to the impact of the development on public facilities and services. The review body must make findings in the development approval that indicate how the required improvements are roughly proportional to the impact. Development may not occur until required transportation facilities are in place or guaranteed, in conformance with the provisions of this code. If

required transportation facilities cannot be put in place or be guaranteed, then the review body shall deny the requested land use application.

Finding: The proposed street improvements will serve the 10 lots and provide connectivity by completing a missing section of W Myrtlewood Drive, as well as a right-of-way dedication and improvements to part of N Crater Lane. This criterion is met.

G. Street Width and Design Standards.

1. Design Standards. All streets shall conform with the standards contained in Table 15.505.030(G). Where a range of values is listed, the director shall determine the width based on a consideration of the total street section width needed, existing street widths, and existing development patterns. Preference shall be given to the higher value. Where values may be modified by the director, the overall width shall be determined using the standards under subsections (G)(2) through (10) of this section.

Table 15.505.030(G)

<i>Type of Street</i>	<i>Right-of-Way Width</i>	<i>Curb-to-Curb Pavement Width</i>	<i>Motor Vehicle Travel Lanes</i>	<i>Median Type</i>	<i>Striped Bike Lane (Both Sides)</i>	<i>On-Street Parking</i>
<i>Local residential</i>	<i>54 – 60 feet</i>	<i>32 feet</i>	<i>2 lanes</i>	<i>None</i>	<i>No</i>	<i>Yes</i>

Finding: The proposed extension of W Myrtlewood Drive is a local residential street. The applicant has proposed a 54-foot-wide right-of-way with a curb-to-curb pavement width of 34 ½ feet. The applicant will be required to construct the proposed W Myrtlewood Drive extension as a 56-foot right-of-way with a cross section matching a “local residential” street. Because final construction plans have not been submitted, final plans showing the right-of-way of the proposed extension of W Myrtlewood Drive as 56 feet with a cross section matching a local residential street will be submitted with the public improvement permit application. The Applicant is also proposing improvements to N Crater Lane to include 9 feet of pavement to provide a 16-foot-wide travel lane, sidewalks, planter strip and curb and gutter. Because final construction plans have not been submitted, final plans of the proposed N Crater Lane street improvements will need to be submitted with the public improvement permit application.

This criterion will be met if all improvements necessary to serve the development meet City standards and are completed.

2. Motor Vehicle Travel Lanes. Collector and arterial streets shall have a minimum width of 12 feet.

Finding: No collector or arterial streets are proposed. This criterion is not applicable.

3. Bike Lanes. Striped bike lanes shall be a minimum of six feet wide. Bike lanes shall be provided where shown in the Newberg transportation system plan.

Finding: W Myrtlewood Drive and N Crater Lane are classified as a local residential street in the City's Transportation System Plan. No bike lanes are required. This criterion does not apply.

4. Parking Lanes. Where on-street parking is allowed on collector and arterial streets, the parking lane shall be a minimum of eight feet wide.

Finding: There are no collector or arterial streets proposed. This criterion is not applicable.

5. Center Turn Lanes. Where a center turn lane is provided, it shall be a minimum of 12 feet wide.

Finding: W Myrtlewood Drive and N Crater Lane are classified as a local residential street in the City's Transportation System Plan. This criterion is not applicable.

6. Limited Residential Streets. Limited residential streets shall be allowed only at the discretion of the review authority, and only in consideration of the following factors:

a. The requirements of the fire chief shall be followed.

b. The estimated traffic volume on the street is low, and in no case more than 600 average daily trips.

c. Use for through streets or looped streets is preferred over cul-de-sac streets.

d. Use for short blocks (under 400 feet) is preferred over longer blocks.

e. The total number of residences or other uses accessing the street in that block is small, and in no case more than 30 residences.

f. On-street parking usage is limited, such as by providing ample off-street parking, or by staggering driveways so there are few areas where parking is allowable on both sides.

Finding: There are no limited residential streets proposed as part of this project. These criteria do not apply.

7. Sidewalks. Sidewalks shall be provided on both sides of all public streets. Minimum width is five feet.

Finding: The submitted plans show Type ‘A’ sidewalks proposed on both sides of the planned extension of W Myrtlewood Drive. An 8-foot wide “sidewalk easement” is shown where the frontage improvements wrap around on N Crater Lane. A 10-foot sidewalk easement along the west side of N Crater north of W Myrtlewood is required for the sidewalk and planter strip widths north of W Myrtlewood to match those south of W Myrtlewood. Because final construction plans have not been submitted, plans showing Type ‘A’ sidewalks improvements on W Myrtlewood Drive and N Crater Lane shall be submitted with the public improvement permit application. The width of the Type ‘A’ sidewalks shall be 5-feet. The indicated sidewalk easement is to have a width of 10-feet where the frontage improvements wrap around on N Crater Lane and shall be recorded and submitted with the public improvement permit application.

This criterion will be met if all improvements necessary to serve the development meet City standards and are completed.

8. Planter Strips. Except where infeasible, a planter strip shall be provided between the sidewalk and the curb line, with a minimum width of five feet. This strip shall be landscaped in accordance with the standards in NMC 15.420.020. Curb-side sidewalks may be allowed on limited residential streets. Where curb-side sidewalks are allowed, the following shall be provided:

a. Additional reinforcement is done to the sidewalk section at corners.

b. Sidewalk width is six feet.

Finding: The submitted plans show planter strips along the proposed extension of W Myrtlewood Drive. The planter strip widths shall be 5.5 feet between the back of curb and the 5-foot-wide sidewalk. Because final construction plans have not been submitted, plans showing planter strips with a minimum of 5.5 feet in width between the back of the curb and the 5-foot-wide sidewalk shall be submitted with the public improvement permit application.

This criterion will be met if all improvements necessary to serve the development meet City standards and are completed.

9. Slope Easements. Slope easements shall be provided adjacent to the street where required to maintain the stability of the street.

Finding: These criteria are not applicable because there are no slopes involved in the proposed subdivision.

10. Intersections and Street Design. The street design standards in the Newberg public works design and construction standards shall apply to all public streets, alleys, bike facilities, and sidewalks in the city.

Finding: The applicant is not proposing modifications to the street standards. This criterion does not apply.

11. The planning commission may approve modifications to street standards for the purpose of ingress or egress to a minimum of three and a maximum of six lots through a conditional use permit.

Finding: The applicant is not proposing modifications to the street standards. This criterion does not apply.

H. Modification of Street Right-of-Way and Improvement Width. The director, pursuant to the Type II review procedures of Chapter 15.220 NMC, may allow modification to the public street standards of subsection (G) of this section, when the criteria in both subsections (H)(1) and (2) of this section are satisfied:

1. The modification is necessary to provide design flexibility in instances where:

a. Unusual topographic conditions require a reduced width or grade separation of improved surfaces; or

b. Lot shape or configuration precludes accessing a proposed development with a street which meets the full standards of this section; or

c. A modification is necessary to preserve trees or other natural features determined by the city to be significant to the aesthetic character of the area; or

d. A planned unit development is proposed and the modification of street standards is necessary to provide greater privacy or aesthetic quality to the development.

2. Modification of the standards of this section shall only be approved if the director finds that the specific design proposed provides adequate vehicular access based on anticipated traffic volumes.

Finding: The applicant is not proposing modifications to the street right-of-way or improvement width. This criterion does not apply.

I. Temporary Turnarounds. Where a street will be extended as part of a future phase of a development, or as part of development of an abutting property, the street may be terminated with a temporary turnaround in lieu of a standard street connection or circular cul-de-sac bulb. The director and fire chief shall approve the temporary turnaround. It shall have an all-weather surface, and may include a hammerhead-type turnaround meeting fire apparatus access road standards, a paved or graveled circular turnaround, or a paved or graveled temporary access road. For streets extending less than 150 feet and/or with no significant access, the director may approve the street without a temporary turnaround. Easements or right-of-way may be required as necessary to preserve access to the turnaround.

Finding: This criterion is not applicable because the fire marshal is not requiring a temporary turnaround.

J. Topography. The layout of streets shall give suitable recognition to surrounding topographical conditions in accordance with the purpose of this code.

Finding: This criterion is not applicable because the surrounding topography is predominately flat.

K. Future Extension of Streets. All new streets required for a subdivision, partition, or a project requiring site design review shall be constructed to be “to and through”:
through the development and to the edges of the project site to serve adjacent properties for future development.

Finding: This criterion is not applicable because the surrounding properties are already developed. There are no possible future street extensions as part of this project. This criterion does not apply.

L. Cul-de-Sacs.

Finding: These criteria are not applicable because no cul-de-sacs are planned for the proposed subdivision.

M. Street Names and Street Signs.

Finding: The applicant proposing W Myrtlewood Drive as the name of the new street. The existing street stubbed to the east boundary of the site is W Myrtlewood Drive. The proposed extension should match the name of the existing street. The applicant shall name the proposed extension W Myrtlewood Drive. This criterion will be met when the proposed extension is named W Myrtlewood Drive.

N. Platting Standards for Alleys.

Finding: These criteria are not applicable because no alleys are being proposed as part of this application.

O. Platting Standards for Blocks.

1. Purpose. Streets and walkways can provide convenient travel within a neighborhood and can serve to connect people and land uses. Large, uninterrupted blocks can serve as a barrier to travel, especially walking and biking. Large blocks also can divide rather than unite neighborhoods. To promote connected neighborhoods and to shorten travel distances, the following minimum standards for block lengths are established.

2. Maximum Block Length and Perimeter. The maximum length and perimeters of blocks in the zones listed below shall be according to the following table. The review body for a subdivision, partition, conditional use permit, or a Type II design review may require installation of streets or walkways as necessary to meet the standards below.

<i>Zone(s)</i>	<i>Maximum Block Length</i>	<i>Maximum Block Perimeter</i>
<i>R-1</i>	<i>800 feet</i>	<i>2,000 feet</i>

3. Exceptions.

a. If a public walkway is installed mid-block, the maximum block length and perimeter may be increased by 25 percent.

b. Where a proposed street divides a block, one of the resulting blocks may exceed the maximum block length and perimeter standards provided the average block length and perimeter of the two resulting blocks do not exceed these standards.

c. Blocks in excess of the above standards are allowed where access controlled streets, street access spacing standards, railroads, steep slopes, wetlands, water bodies, preexisting development, ownership patterns or similar circumstances restrict street and walkway location and design. In these cases, block length and perimeter shall be as small as practical. Where a street cannot be provided because of these circumstances but a public walkway is still feasible, a public walkway shall be provided.

d. Institutional campuses located in an R-1 zone may apply the standards for the institutional zone.

e. Where a block is in more than one zone, the standards of the majority of land in the proposed block shall apply.

f. Where a local street plan, concept master site development plan, or specific plan has been approved for an area, the block standards shall follow those approved in the plan. In approving such a plan, the review body shall follow the block standards listed above to the extent appropriate for the plan area.

Finding: W Myrtlewood Drive extension is a natural extension of the street and will complete the final connection of W Myrtlewood Drive between N Main Street and N Crater Lane. W Myrtlewood Drive between N Main Street and N Crater Lane is approximately 500 feet, well under the maximum block length permitted. No exceptions are necessary. The standard is met.

P. Private Streets.

Finding: This criterion is not applicable because no private streets are being proposed as part of the proposed subdivision.

Q. Traffic Calming.

1. The following roadway design features may be required in new street construction where traffic calming needs are anticipated:

a. Serpentine alignment.

b. Curb extensions.

c. Traffic diverters/circles.

d. Raised medians and landscaping.

e. Other methods shown effective through engineering studies.

2. Traffic-calming measures such as speed humps should be applied to mitigate traffic operations and/or safety problems on existing streets. They should not be applied with new street constructions.

Finding: The applicant is not proposing traffic calming. This criterion does not apply.

R. Vehicular Access Standards.

1. Purpose. The purpose of these standards is to manage vehicle access to maintain traffic flow, safety, roadway capacity, and efficiency. They help to maintain an adequate level of service consistent with the functional classification of the street. Major roadways, including arterials and collectors,

serve as the primary system for moving people and goods within and through the city. Access is limited and managed on these roads to promote efficient through movement. Local streets and alleys provide access to individual properties. Access is managed on these roads to maintain safe maneuvering of vehicles in and out of properties and to allow safe through movements. If vehicular access and circulation are not properly designed, these roadways will be unable to accommodate the needs of development and serve their transportation function.

2. Access Spacing Standards. Public street intersection and driveway spacing shall follow the standards in Table 15.505.R below. The Oregon Department of Transportation (ODOT) has jurisdiction of some roadways within the Newberg city limits, and ODOT access standards will apply on those roadways.

Finding: There are no access spacing standards for local streets. These criteria do not apply.

3. Properties with Multiple Frontages. Where a property has frontage on more than one street, access shall be limited to the street with the lesser classification.

Finding: Only one lot in the subdivision will have multiple frontages, Lot 2. It will abut N Crater Lane and W Myrtlewood Drive, both are classified as local streets according to the Newberg TSP. Therefore, Lot 2 can take access from either street. The standard is met.

4. Driveways. More than one driveway is permitted on a lot accessed from either a minor collector or local street as long as there is at least 40 feet of lot frontage separating each driveway approach. More than one driveway is permitted on a lot accessed from a major collector as long as there is at least 100 feet of lot frontage separating each driveway approach.

Finding: The applicant's preliminary plat does not show driveway locations. Future development on the lots will be required to adhere to this standard. This criterion does not apply.

5. Alley Access. Where a property has frontage on an alley and the only other frontages are on collector or arterial streets, access shall be taken from the alley only. The review body may allow creation of an alley for access to lots that do not otherwise have frontage on a public street provided all of the following are met:

a. The review body finds that creating a public street frontage is not feasible.

b. The alley access is for no more than six dwellings and no more than six lots.

c. The alley has through access to streets on both ends.

d. One additional parking space over those otherwise required is provided for each dwelling. Where feasible, this shall be provided as a public use parking space adjacent to the alley.

Finding: These criteria are not applicable because no alleys are proposed as part of this application.

6. Closure of Existing Accesses. Existing accesses that are not used as part of development or redevelopment of a property shall be closed and replaced with curbing, sidewalks, and landscaping, as appropriate.

Finding: This criterion is not applicable because no closure of existing accesses is proposed.

7. Shared Driveways.

a. The number of driveways onto arterial streets shall be minimized by the use of shared driveways with adjoining lots where feasible. The city shall require shared driveways as a condition of land division or site design review, as applicable, for traffic safety and access management purposes. Where there is an abutting developable property, a shared driveway shall be provided as appropriate. When shared driveways are required, they shall be stubbed to adjacent developable parcels to indicate future extension. "Stub" means that a driveway temporarily ends at the property line, but may be accessed or extended in the future as the adjacent parcel develops. "Developable" means that a parcel is either vacant or it is likely to receive additional development (i.e., due to infill or redevelopment potential).

b. Access easements (i.e., for the benefit of affected properties) and maintenance agreements shall be recorded for all shared driveways, including pathways, at the time of final plat approval or as a condition of site development approval.

c. No more than four lots may access one shared driveway.

d. Shared driveways shall be posted as no parking fire lanes where required by the fire marshal.

e. Where three lots or three dwellings share one driveway, one additional parking space over those otherwise required shall be provided for each dwelling. Where feasible, this shall be provided as a common use parking space adjacent to the driveway.

Finding: The applicant's preliminary plans show a 25-foot-wide shared driveway approach providing access to Lot 4 and 5, and a second shared driveway approach for Lots 8 and 9. The

applicant has not indicated the need for a shared access and maintenance agreement in addition to the proposed easement. Because a shared access and maintenance agreement and easement documentation have not been recorded, the applicant will be required to obtain and record a shared driveway approach, access, and maintenance agreement for the proposed shared driveway serving Lot 4 and Lot 5 and the shared driveway serving Lot 8 and Lot 9 at the time of final plat approval.

The criterion will be met if the aforementioned condition of approval is adhered to.

8. Frontage Streets and Alleys. The review body for a partition, subdivision, or design review may require construction of a frontage street to provide access to properties fronting an arterial or collector street.

Finding: This proposal does not include properties fronting arterial or collector streets. This criterion does not apply.

9. ODOT or Yamhill County Right-of-Way. Where a property abuts an ODOT or Yamhill County right-of-way, the applicant for any development project shall obtain an access permit from ODOT or Yamhill County.

Finding: The applicant's project is not located proximate to ODOT or Yamhill County right-of-way. This criterion is not applicable.

10. Exceptions. The director may allow exceptions to the access standards above in any of the following circumstances:

a. Where existing and planned future development patterns or physical constraints, such as topography, parcel configuration, and similar conditions, prevent access in accordance with the above standards.

b. Where the proposal is to relocate an existing access for existing development, where the relocated access is closer to conformance with the standards above and does not increase the type or volume of access.

c. Where the proposed access results in safer access, less congestion, a better level of service, and more functional circulation, both on street and on site, than access otherwise allowed under these standards.

11. Where an exception is approved, the access shall be as safe and functional as practical in the particular circumstance. The director may require that the applicant submit a traffic study by a registered engineer to show the proposed access meets these criteria.

Finding: The applicant is not proposing any exceptions. These criteria are not applicable.

S. Public Walkways.

1. Projects subject to Type II design review, partition, or subdivision approval may be required to provide public walkways where necessary for public safety and convenience, or where necessary to meet the standards of this code. Public walkways are meant to connect cul-de-sacs to adjacent areas, to pass through oddly shaped or unusually long blocks, to provide for networks of public paths according to adopted plans, or to provide access to schools, parks or other community destinations or public areas. Where practical, public walkway easements and locations may also be used to accommodate public utilities.

2. Public walkways shall be located within a public access easement that is a minimum of 15 feet in width.

3. A walk strip, not less than 10 feet in width, shall be paved in the center of all public walkway easements. Such paving shall conform to specifications in the Newberg public works design and construction standards.

4. Public walkways shall be designed to meet the Americans with Disabilities Act requirements.

5. Public walkways connecting one right-of-way to another shall be designed to provide as short and straight of a route as practical.

6. The developer of the public walkway may be required to provide a homeowners' association or similar entity to maintain the public walkway and associated improvements.

7. Lighting may be required for public walkways in excess of 250 feet in length.

8. The review body may modify these requirements where it finds that topographic, preexisting development, or similar constraints exist.

Finding: The applicant is not proposing public walkways. This criterion is not applicable.

T. Street Trees. Street trees shall be provided for all projects subject to Type II design review, partition, or subdivision. Street trees shall be installed in accordance with the provisions of NMC 15.420.010(B)(4).

Finding: The applicant preliminary plat shows curb side planter strips along both sides of W Myrtlewood Drive and on N Crater Lane where it abuts the site. The applicant will need to ensure the street trees are planted in accordance NMC 15.420.010(B)(4)(b), street trees shall be spaced approximately 35 to 40 feet on center.

The criterion will be met if the aforementioned condition of approval is adhered to.

U. Street Lights. All developments shall include underground electric service, light standards, wiring and lamps for street lights according to the specifications and standards of the Newberg public works design and construction standards. The developer shall install all such facilities and make the necessary arrangements with the serving electric utility as approved by the city. Upon the city's acceptance of the public improvements associated with the development, the street lighting system, exclusive of utility-owned service lines, shall be and become property of the city unless otherwise designated by the city through agreement with a private utility.

Finding: The applicant's plans show proposed street lighting. However, it is unclear if the City's requirements for street lighting are being met. Because a lighting analysis has not been provided, the applicant will be required to show via a lighting analysis that the street lighting along the proposed W Myrtlewood Drive extension and east side of N Crater Lane meets City standards or provide additional street lighting that is compliant with the City's Public Works Design and Construction Standards.

The criterion will be met if the aforementioned condition of approval is adhered to.

V. Transit Improvements.

Finding: These criteria are not applicable because no transit improvements are being proposed for this application.

15.505.040 Public utility standards.

C. General Standards.

1. The design and construction of all improvements within existing and proposed rights-of-way and easements, all improvements to be maintained by the city, and all improvements for which city approval is required shall conform to the Newberg public works design and construction standards and require a public improvements permit.

2. The location, design, installation and maintenance of all utility lines and facilities shall be carried out with minimum feasible disturbances of soil and site. Installation of all proposed public and private utilities shall be coordinated by the developer and be approved by the city to ensure the orderly extension of such utilities within public right-of-way and easements.

D. Standards for Water Improvements. All development that has a need for water service shall install the facilities pursuant to the requirements of the city and all of the following standards. Installation of such facilities shall be coordinated with the

extension or improvement of necessary wastewater and stormwater facilities, as applicable.

1. All developments shall be required to be linked to existing water facilities adequately sized to serve their intended area by the construction of water distribution lines, reservoirs and pumping stations which connect to such water service facilities. All necessary easements required for the construction of these facilities shall be obtained by the developer and granted to the city pursuant to the requirements of the city.

2. Specific location, size and capacity of such facilities will be subject to the approval of the director with reference to the applicable water master plan. All water facilities shall conform with city pressure zones and shall be looped where necessary to provide adequate pressure and fire flows during peak demand at every point within the system in the development to which the water facilities will be connected. Installation costs shall remain entirely the developer's responsibility.

3. The design of the water facilities shall take into account provisions for the future extension beyond the development to serve adjacent properties, which, in the judgment of the city, cannot be feasibly served otherwise.

4. Design, construction and material standards shall be as specified by the director for the construction of such public water facilities in the city.

Finding: Preliminary plans show a new water line in the extension of W Myrtlewood Drive connecting to the existing waterline in W Myrtlewood Drive and the existing water line in N Crater Lane. No size is given. One fire hydrant is shown on the proposed plan on the south side of the proposed extension in the sidewalk north of Lot 2. Because the applicant has not submitted construction plans, final plans for water system improvements meeting requirements of the Newberg Public Works Design and Construction Standards shall be submitted with the public improvement permit application. These criteria will be met if all improvements necessary to service the development meet City standards and are completed.

The criterion will be met if the aforementioned condition of approval is adhered to.

E. Standards for Wastewater Improvements. All development that has a need for wastewater services shall install the facilities pursuant to the requirements of the city and all of the following standards. Installation of such facilities shall be coordinated with the extension or improvement of necessary water services and stormwater facilities, as applicable.

1. All septic tank systems and on-site sewage systems are prohibited. Existing septic systems must be abandoned or removed in accordance with Yamhill County standards.

Finding: The applicant's existing conditions plan indicate an existing septic field will be decommissioned per City of Newberg specification and Oregon Administrative Rules. The applicant will need to submit confirmation of abandonment or removal of the septic field pursuant to applicable Yamhill County and state regulations prior to issuance of final plat.

The criterion will be met if the aforementioned condition of approval is adhered to.

2. All properties shall be provided with gravity service to the city wastewater system, except for lots that have unique topographic or other natural features that make gravity wastewater extension impractical as determined by the director. Where gravity service is impractical, the developer shall provide all necessary pumps/lift stations and other improvements, as determined by the director.

3. All developments shall be required to be linked to existing wastewater collection facilities adequately sized to serve their intended area by the construction of wastewater lines which connect to existing adequately sized wastewater facilities. All necessary easements required for the construction of these facilities shall be obtained by the developer and granted to the city pursuant to the requirements of the city.

4. Specific location, size and capacity of wastewater facilities will be subject to the approval of the director with reference to the applicable wastewater master plan. All wastewater facilities shall be sized to provide adequate capacity during peak flows from the entire area potentially served by such facilities. Installation costs shall remain entirely the developer's responsibility.

5. Temporary wastewater service facilities, including pumping stations, will be permitted only if the director approves the temporary facilities, and the developer provides for all facilities that are necessary for transition to permanent facilities.

6. The design of the wastewater facilities shall take into account provisions for the future extension beyond the development to serve upstream properties, which, in the judgement of the city, cannot be feasibly served otherwise.

7. Design, construction and material standards shall be as specified by the director for the construction of such wastewater facilities in the city.

Finding: Preliminary plans show a new wastewater line installed in the proposed extension of W Myrtlewood Drive. The proposed wastewater line is shown connecting to an existing wastewater line in N Crater Lane. The size of the proposed line is not shown. The plans do show wastewater services extended in the shared driveways serving lots 8 & 9 and 5 & 4. Each set of lots on the shared driveways is shown served by one connection to the public line. Each lot will need its own connection to the public line. Because the applicant has not submitted construction plans,

final plans for the wastewater system improvements meeting requirements of the Newberg Public Works Design and Construction Standards will be submitted with the public improvement permit application. This criterion will be met if all wastewater improvements necessary to service the development meet City standards and are completed.

The criterion will be met if the aforementioned condition of approval is adhered to.

F. Easements. Easements for public and private utilities shall be provided as deemed necessary by the city, special districts, and utility companies. Easements for special purpose uses shall be of a width deemed appropriate by the responsible agency. Such easements shall be recorded on easement forms approved by the city and designated on the final plat of all subdivisions and partitions. Minimum required easement width and locations are as provided in the Newberg public works design and construction standards. [Ord. 2810 § 2 (Exhs. B, C), 12-19-16.]

Finding: The applicant has submitted preliminary drawings that show 8-foot public utility easements, an 8-foot sidewalk easement, 25-foot access and utility easements over each shared driveway, and an easement of variable width across the 42-inch pipe proposed to collect flows from the creek on the southern boundary of the property. There is no easement shown where the 42-inch pipe leaves the property extending across the northern end of the property adjacent to the south. Public utility easements are to be 10-feet in width. Because the applicant has not recorded all utility easements, the applicant will be required to submit recorded documents that include necessary utility easements meeting the specifications and standards of the City's Public Works Design and Construction Standards, but not necessarily limited to:

- 1) 10-foot public utility easements along all public street frontages
- 2) 10-foot sidewalk easement for the N Crater Lane street improvements north of W Myrtlewood
- 3) 25-foot utility easement over the water and sewer line in both shared driveways and over the storm line shown in the shared driveway serving lots 4 & 5.
- 4) For the east-west section of the proposed 42-inch storm line the easement shall be 10-foot minimum offset from the centerline of the 42-inch pipe to the north and extending south of the 42-inch pipe to the boundary line, terminating at the public right-of-way.
- 5) Maintain and protect all existing utilities easements encumbered on the property.

The criterion will be met if the aforementioned condition of approval is adhered to.

15.505.050 Stormwater system standards.

A. Purpose. The purpose of this section is to provide for the drainage of surface water from all development; to minimize erosion; and to reduce degradation of water quality due to sediments and pollutants in stormwater runoff.

B. Applicability. The provisions of this section apply to all developments subject to site development review or land division review and to the reconstruction or expansion of such developments that increases the flow or changes the point of discharge to the city stormwater system. Additionally, the provisions of this section shall apply to all drainage facilities that impact any public storm drain system, public right-of-way or public easement, including but not limited to off-street parking and loading areas.

C. General Requirement. All stormwater runoff shall be conveyed to a public storm wastewater or natural drainage channel having adequate capacity to carry the flow without overflowing or otherwise causing damage to public and/or private property. The developer shall pay all costs associated with designing and constructing the facilities necessary to meet this requirement.

Finding: The applicant's narrative and preliminary plans show the applicant will be installing stormwater facilities in Tract A to address the quality and quantity of stormwater runoff from the development prior to being released into an existing storm pipe in N Crater Lane. Additionally, the applicant is proposing to replace a drainage ditch/tributary A that runs around the southeast corner of the property, along the southern property line, along the northern edges of the properties to the south of the site, and under N Crater Lane in a group of culverts with a 42-inch pipe and increase the size of the culverts that convey flows under N Crater Lane. Preliminary conveyance calculations have been submitted as part of this application. The group of culverts that convey flows under N Crater Lane were proposed to be increased in size due to flooding. It is not clear whether modifying the flow regime from a drainage ditch to a 42-inch pipe will impact the downstream channel stability. Additionally, there is a public force main installed over a part of the drainage ditch alignment. Any construction will have to protect that public force main from damage during and after construction. Because the applicant has not provided construction plans or a final stormwater report, the applicant will be required to provide detailed construction plans and a final stormwater report with the public improvement permit application that address requirements outlined in the Public Works Design and Construction Standards in accordance with NMC 13.25 Stormwater Management. These requirements include a paved access to any stormwater facilities within the proposed public storm easement. This includes providing a maintenance access road to the proposed storm manholes along the proposed 42" storm line along the southern boundary of the site. As part of the public improvement permit plan review process, it may be determined that this access road requires a wider easement than shown for accessing the storm manhole on lot 4 of the preliminary plat. Any construction will have to protect that public force main from damage during and after construction.

The criterion will be met if the aforementioned condition of approval is adhered to.

D. Plan for Stormwater and Erosion Control. No construction of any facilities in a development included in subsection (B) of this section shall be permitted until an engineer registered in the State of Oregon prepares a stormwater report and erosion control plan for the project. This plan shall contain at a minimum:

1. The methods to be used to minimize the amount of runoff, sedimentation, and pollution created from the development both during and after construction.

2. Plans for the construction of stormwater facilities and any other facilities that depict line sizes, profiles, construction specifications, and other such information as is necessary for the city to review the adequacy of the stormwater plans.

3. Design calculations shall be submitted for all drainage facilities. These drainage calculations shall be included in the stormwater report and shall be stamped by a licensed professional engineer in the State of Oregon. Peak design discharges shall be computed based upon the design criteria outlined in the public works design and construction standards for the city.

Finding: The applicant's plans show site disturbance of greater than one acre. Because the applicant as not provided documentation of an erosion and sedimentation control permit for the development site, the applicant will be required to obtain and submit a DEQ 1200-C permit prior to issuance of a public improvement permit.

The applicant has submitted a preliminary stormwater management report. The report describes stormwater detention and treatment in Tract A. Lots 3,4,5,6,7,8,9, and 10 are shown connected to the stormwater line draining to the facility in Tract A. Lot 2 is shown connected to the storm line leaving the facility in Tract A and connecting to a storm line across N Crater Lane in the existing Myrtlewood Drive. Lot 1 drains to a 42-inch storm line proposed along the southern boundary of the site to replace an existing drainage ditch. The application indicates that these lots as well as some impervious area in the proposed street improvements cannot drain to Tract A because of grading. The preliminary drainage report proposes routing drainage from a basin upstream of the existing W Myrtlewood Drive (Basin 301) to Tract A for treatment in place of the impervious area from lots 1 and 2 and pavement from street improvements which cannot be routed to Tract A. It is unclear if the drainage from the basin upstream of the existing W Myrtlewood Drive is already being treated and detained from a previously conditioned stormwater quality facility.

A final stormwater report will need to be submitted with the Public Improvement Permit and will be completely reviewed at that time. Because the applicant has not submitted a final stormwater report or construction plans, the applicant will need to submit a final stormwater report and

construction plans meeting the City’s Public Works Design and Construction Standards and NMC 13.25 Stormwater Management requirements and obtain a Public Improvement Permit.

The criterion will be met if the aforementioned conditions of approval are adhered to.

E. Development Standards. Development subject to this section shall be planned, designed, constructed, and maintained in compliance with the Newberg public works design and construction standards. [Ord. 2810 § 2 (Exhs. B, C), 12-19-16.]

Finding: The applicant’s narrative and preliminary plans show the applicant will be installing stormwater facilities to address quality and quantity of stormwater runoff from the development prior to being released into an existing storm pipe in N Crater Lane. A stormwater final report will need to be submitted with the Public Improvement Permit and will be completely reviewed at that time. Because the applicant has not submitted a final stormwater report or construction plans, the applicant will need to submit a final stormwater report and construction plans meeting the City’s Public Works Design and Construction Standards and NMC 13.25 Stormwater Management requirements and obtain a Public Improvement Permit. Utility designs and alignments will be reviewed as part of the Public Improvement Permit.

The criterion will be met if the aforementioned condition of approval is adhered to.

15.235.050(A) Preliminary plat approval criteria (continued).

4. The proposed plat name is not already recorded for another subdivision, and satisfies the provisions of ORS Chapter 92;

Finding: The proposed plat name of the subdivision is “Myrtlewood Subdivision,” which is not already recorded for another subdivision, and satisfies the provisions of ORS Chapter 92. The applicant narrative states they are in process of receiving approval to reserve the name from Yamhill County. Once received, a notification of reservation from Yamhill County must be provided.

This criterion is met, subject to the condition.

5. The proposed streets, utilities, and stormwater facilities are adequate to serve the proposed development at adopted level of service standards, conform to city of Newberg adopted master plans and applicable Newberg public works design and construction standards, and allow for transitions to existing and potential future development on adjacent lands. The preliminary plat shall identify all proposed public improvements and dedications;

Finding: The proposed streets, utility, and stormwater improvements comply with adopted master plans and design standards, as conditioned in Section III.

6. All proposed private common areas and improvements, if any, are identified on the preliminary plat and maintenance of such areas is assured through the appropriate legal instrument;

Finding: There are proposed shared-access drives serving Lots 4, 5, 8 and 9. A tract for a stormwater facility is proposed on the plans, but the applicant does not address on-going maintenance or ownership of the tract. Access easements and stormwater maintenance agreements shall be recorded for all shared driveways and private stormwater facilities as part of the final platting process.

This criterion will be met with the adherence to the aforementioned condition of approval.

7. Evidence that any required state and federal permits, as applicable, have been obtained or can reasonably be obtained prior to development; and

Finding: Based on the applicant's submittal, the application identifies a wetland on the site. Daniel Evans, a Division of State Lands (DSL) representative emailed on November 5, 2021, stating that "DSL is presuming jurisdiction on Tributary A." The applicant will be required to submit copies of any federal and/or state permits necessary to replace Tributary A with a storm collection pipe or provide documentation from federal and state agencies that no permits are required. This documentation of federal and/or state permitting is to be submitted with the public improvement permit application. Plans for stormwater system improvements meeting requirements of the Newberg Public Works Design and Construction Standards shall be submitted with the public improvement permit application.

8. Evidence that improvements or conditions required by the city, road authority, Yamhill County, special districts, utilities, and/or other service providers, as applicable to the project, have been or can be met.

Finding: This provision can be met through the submission and review of subdivision plans. The required improvements will be made prior to final plat approval. Conditions of Approval are listed in Section III attached hereto.

Conclusion: Based on the above-mentioned findings, the application meets the required criteria within the Newberg Development Code, subject to completion of the attached conditions.

Section III: Conditions –File SUB218-0002 Myrtlewood Subdivision

- A.** The applicant is conditioned to complete construction (i.e. required public improvements, utilities, streets) for the subdivision phase within two years of the decision date.
- B.** The applicant is conditioned to record the final plat within the subdivision approval period.
- C.** General Requirements for the Public Improvement Permit:

The Public Works Design and Construction Standards require that the applicant submit engineered construction plans for review and approval of all utilities, public street improvements, and any new public streets being constructed. Please note that additional Engineering Department plan review application and fees apply for review of plans. Submit any required easements for review and approval and record approved easements. No construction of, or connection to, any existing or proposed public utility/improvements will be permitted until all plans are approved and all necessary permits have been obtained.

- D.** The plans must note the following (Conditions of Approval):
- E.** The applicant must provide the following information for review and approval prior to construction of any improvements:

1. Vision Clearance

- a. Future development on the proposed lots will be required to demonstrate vision clearance triangles on plans and keep them clear of all visual obstructions pursuant to this standard.

2. Streets, Sidewalks, and Street Trees

- a. Final plans of the proposed N Crater Lane street improvements will need to be submitted with the public improvement permit application.
- b. The 10-foot right-of-way dedication along the site's N Crater Lane frontage shall be shown on construction plans and on the final plat.
- c. Final plans showing the right-of-way of the proposed extension of W Myrtlewood Drive as 56 feet with a cross section matching a local residential street shall be submitted with the public improvement permit application.
- d. Plans describing a 56-foot right-of-way for W Myrtlewood Drive with a cross section design matching the City's Transportation System Plan and Public Works Design and Construction Standards for a "local residential" street shall be submitted with the public improvement permit application:
 - i. 1-foot from back of walk to right-of-way

- ii. 5-foot sidewalk
- iii. 5.5-foot planter
- iv. 0.5-foot curb
- v. 7-foot parking lane
- vi. 9-foot drive lane
- vii. 9-foot drive lane
- viii. 7-foot parking lane
- ix. 0.5-foot curb
- x. 5.5-foot planter
- xi. 5-foot sidewalk
- xii. 1-foot from back of walk to right-of-way
- e. Plans showing Type ‘A’ sidewalks improvements on W Myrtlewood Drive and N Crater Lane shall be submitted with the public improvement permit application. The width of the Type ‘A’ sidewalks shall be 5-feet.
- f. The indicated sidewalk easement is to have a width of 10-feet where the frontage improvements wrap around on N Crater Lane and shall be recorded and submitted with the public improvement permit application.
- g. Plans showing planter strips with a minimum of 5.5 feet in width between the back of the curb and the 5-foot-wide sidewalk shall be submitted with the public improvement permit application.
- h. The applicant shall name the proposed extension W Myrtlewood Drive.
- i. The applicant will need to ensure the street trees are planted in accordance NMC 15.420.010(B)(4)(b), street trees shall be spaced approximately 35 to 40 feet on center.
- j. The applicant will be required to obtain and record a shared driveway approach, access, and maintenance agreement for the proposed shared driveway serving Lot 4 and Lot 5 and the shared driveway serving Lot 8 and Lot 9 at the time of final plat approval.
- k. The applicant will be required to show via a lighting analysis that the street lighting along the proposed W Myrtlewood extension and east side of N Crater Lane meets City standards or provide additional street lighting that is compliant with the City’s Public Works Design and Construction Standards.

3. Utilities

- a. Final plans showing the public utility easements as 10-feet wide will be required to be submitted with the public improvement permit application.

4. Water

- a. Plans for water system improvements meeting requirements of the Newberg Public Works Design and Construction Standards shall be submitted with the public improvement permit application.

- b. Final plans for water system improvements meeting requirements of the Newberg Public Works Design and Construction Standards shall be submitted with the public improvement permit application.

5. Wastewater

- a. Plans for wastewater system improvements meeting requirements of the Newberg Public Works Design and Construction Standards shall be submitted with the public improvement permit application. Plans to include the size of the proposed wastewater line and individual services to lots 8, 9, 5, and 4.
- b. The applicant will need to submit confirmation of abandonment or removal of the septic field pursuant to applicable Yamhill County and state regulations prior to issuance of final plat.
- c. Final plans for the wastewater system improvements meeting requirements of the Newberg Public Works Design and Construction Standards shall be submitted with the public improvement permit application.

6. Stormwater

- a. The applicant will be required to submit copies of any federal and/or state permits necessary to replace Tributary A with a storm collection pipe or provide documentation from federal and state agencies that no permits are required. This documentation of federal and/or state permitting is to be submitted with the public improvement permit application.
- b. The applicant will be required to provide detailed construction plans and a final stormwater report with the public improvement permit application that address requirements outlined in the Public Works Design and Construction Standards in accordance with NMC 13.25 Stormwater Management. These requirements include a paved access to any stormwater facilities within the proposed public storm easement. This includes providing a maintenance access road to the proposed storm manholes along the proposed 42" storm line along the southern boundary of the site. As part of the public improvement permit plan review process, it may be determined that this access road requires a wider easement than shown for accessing the storm manhole on lot 4 of the preliminary plat. Any construction will have to protect that public force main from damage during and after construction.
- c. The applicant will be required to obtain and submit a DEQ 1200-C permit prior to issuance of a public improvement permit.
- d. The applicant will need to submit a final stormwater report and construction plans meeting the City's Public Works Design and Construction Standards and NMC 13.25 Stormwater Management requirements and obtain a Public Improvement Permit.
- e. The applicant will need to submit a final stormwater report and construction plans meeting the City's Public Works Design and

Construction Standards and NMC 13.25 Stormwater Management requirements and obtain a Public Improvement Permit. Utility designs and alignments will be reviewed as part of the Public Improvement Permit.

7. Easements

- a. The applicant will be required to submit recorded documents that include necessary utility easements meeting the specifications and standards of the City's Public Works Design and Construction Standards, but not necessarily limited to:
 - i. 10-foot public utility easements along all public street frontages
 - ii. 10-foot sidewalk easement for the N Crater Lane street improvements north of W Myrtlewood
 - iii. 25-foot utility easement over the water and sewer line in both shared driveways and over the storm line shown in the shared driveway serving lots 4 & 5.
 - iv. For the east-west section of the proposed 42-inch storm line the easement shall be 10-foot minimum offset from the centerline of the 42-inch pipe to the north and extending south of the 42-inch pipe to the boundary line, terminating at the public right-of-way.
 - v. Maintain and protect all existing utilities easements encumbered on the property.

8. Other

- a. The applicant must submit a notification of name reservation from Yamhill County once available.

F. The applicant must complete the following prior to final plat approval.

- a. **Substantially Complete the Construction Improvements:** Prior to final plat approval, the applicant must substantially complete the construction improvements and secure for them in accordance with city policy. Complete construction and call for a walk-through inspection with the Engineering Division (503-537-1273). In addition to those items listed below, the inspector will also be looking for completion of items such as sidewalks, street signs, streetlights, and fire hydrants.
 - i. Construct all approved public utility lines.
 - ii. Underground all utilities crossing the site.

G. Final plat submission requirements and approval criteria: In accordance with NDC 15.235.070, final plats require review and approval by the director prior to recording with

Yamhill County. The final plat submission requirements, approval criteria, and procedure are as follows:

1. Submission Requirements:

The applicant shall submit the final plat within two years, or as otherwise provided for in NMC 15.235.030. The format of the plat shall conform to ORS Chapter 92. The final plat application shall include the following items:

- a. One original and one identical copy of the final plat for signature. The plat copies shall be printed on mylar, and must meet the requirements of the county recorder and county surveyor. The plat must contain a signature block for approval by the city recorder and community development director, in addition to other required signature blocks for county approval. Preliminary paper copies of the plat are acceptable for review at the time of final plat application.
- b. Written response to any conditions of approval assigned to the land division.
- c. A title report for the property, current within six months of the final plat application date.
- d. Copies of any required dedications, easements, or other documents.
- e. Copies of all homeowner's agreements, codes, covenants, and restrictions, or other bylaws, as applicable. This shall include documentation of the formation of a homeowner's association, including but not limited to a draft homeowner's association agreement regarding the maintenance of planter strips adjacent to the rear yard of proposed through lots.
- f. Copies of any required maintenance agreements for common property.
- g. A bond, as approved by the city engineer, for public infrastructure improvements, if the improvements are not substantially complete prior to the final plat.
- h. Any other item required by the city to meet the conditions of approval assigned to the land division.

2. Approval Process and Criteria. By means of a Type I procedure, the director shall review and approve, or deny, the final plat application based on findings of compliance or noncompliance with the preliminary plat conditions of approval

H. Filing and recording: In accordance with NDC 15.235.080, a new lot is not a legal lot for purposes of ownership (title), sale, lease, or development/land use until a final plat is

recorded for the subdivision or partition containing the lot. The final plat filing and recording requirements are as follows:

1. **Filing Plat with County.** Within 60 days of the city approval of the final plat, the applicant shall submit the final plat to Yamhill County for signatures of county officials as required by ORS Chapter 92.
2. **Proof of Recording.** Upon final recording with the county, the applicant shall submit to the city a paper copy of all sheets of the recorded final plat. This shall occur prior to the issuance of building permits for the newly created lots.
3. **Prerequisites to Recording the Plat.**

a. No plat shall be recorded unless all ad valorem taxes and all special assessments, fees, or other charges required by law to be placed on the tax roll have been paid in the manner provided by ORS Chapter 92;

No plat shall be recorded until the county surveyor approves it in the manner provided by ORS Chapter 92.

I. Development Notes:

1. **Postal Service:** The applicant shall submit plans to the Newberg Postmaster for approval of proposed mailbox delivery locations. Contact the Newberg Post Office for assistance at 503-554-8014.
2. **PGE:** PGE can provide electrical service to this project under terms of the current tariff which will involve developer expense and easements. Contact the Service & Design Supervisor, PGE, at 503-463-4348.
3. **Zipty:** The developer must coordinate trench/conduit requirements with Zipty. Contact the Engineering Division, Zipty, at 541-269-3375.
4. **Addresses:** The Planning Division will assign addresses for the new subdivision. Planning Division staff will send out notice of the new addresses after they receive a recorded copy of the final subdivision plat.

Attachment 1: Agency Comments



Community Development Planning Division Land Use Application Referral

REFERRAL TO: Building Official, Brooks Bateman

The enclosed material has been referred to you for your information and comment. Any comments you wish to make should be returned to the Community Development Department prior to November 2, 2021. Please refer questions and comments to Doug Rux.

NOTE: Full size plans are available at the Community Development Department Office.

APPLICANT: Nick Daniken

REQUEST: 10 Lot residential subdivision in the low-density residential district.

SITE ADDRESS: 2900 N Crater Lane,

LOCATION: Newberg

TAX LOT: R3207 03202

FILE NO: SUB221-0002

ZONE: R-1

RECEIVED
OCT 25 2021
 Initial: _____

-
- Reviewed, no conflict.
 - Reviewed; recommend denial for the following reasons:
 - Require additional information to review. (Please list information required)
 - Meeting requested.
 - Comments. (Attach additional pages as needed)

Brooks Bateman
 Reviewed By:

10/22/21
 Date:



Community Development Planning Division
Land Use Application Referral

REFERRAL TO: Finance,

The enclosed material has been referred to you for your information and comment. Any comments you wish to make should be returned to the Community Development Department prior to November 2, 2021. Please refer questions and comments to Doug Rux.

NOTE: Full size plans are available at the Community Development Department Office.

APPLICANT: Nick Daniken
REQUEST: 10 Lot residential subdivision in the low-density residential district.
SITE ADDRESS: 2900 N Crater Lane,
LOCATION: Newberg
TAX LOT: R3207 03202
FILE NO: SUB221-0002
ZONE: R-1

RECEIVED

OCT 20 2021

Initial: _____

- Reviewed, no conflict. *no city lien*
- Reviewed; recommend denial for the following reasons:
- Require additional information to review. (Please list information required)
- Meeting requested.
- Comments. (Attach additional pages as needed)

Reviewed By:

10/19/21

Date:

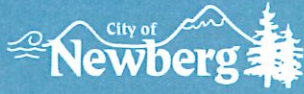

Community Development Planning Division
Land Use Application Referral

REFERRAL TO: Police Department, Chief Jeff Kosmicki

The enclosed material has been referred to you for your information and comment. Any comments you wish to make should be returned to the Community Development Department prior to November 2, 2021. Please refer questions and comments to Doug Rux.

NOTE: Full size plans are available at the Community Development Department Office.

APPLICANT: Nick Daniken
REQUEST: 10 Lot residential subdivision in the low-density residential district.
SITE ADDRESS: 2900 N Crater Lane,
LOCATION: Newberg
TAX LOT: R3207 03202
FILE NO: SUB221-0002
ZONE: R-1

-
- Reviewed, no conflict.
 Reviewed; recommend denial for the following reasons:
 Require additional information to review. (Please list information required)
 Meeting requested.
 Comments. (Attach additional pages as needed)



Reviewed By:

10/20/2021
Date:



Community Development Planning Division
Land Use Application Referral

REFERRAL TO: Public Works: Maintenance , Vance Barton

The enclosed material has been referred to you for your information and comment. Any comments you wish to make should be returned to the Community Development Department prior to November 2, 2021. Please refer questions and comments to Doug Rux.

NOTE: Full size plans are available at the Community Development Department Office.

APPLICANT: Nick Daniken
REQUEST: 10 Lot residential subdivision in the low-density residential district.
SITE ADDRESS: 2900 N Crater Lane,
LOCATION: Newberg
TAX LOT: R3207 03202
FILE NO: SUB221-0002
ZONE: R-1

Carl Ramseyer

Vance Barton

Comments on page 34 10/26/2021

[Signature]

11/3/21

- Reviewed, no conflict.
- Reviewed; recommend denial for the following reasons:
- Require additional information to review. (Please list information required)
- Meeting requested.
- Comments. (Attach additional pages as needed)

Reviewed By:

Date:

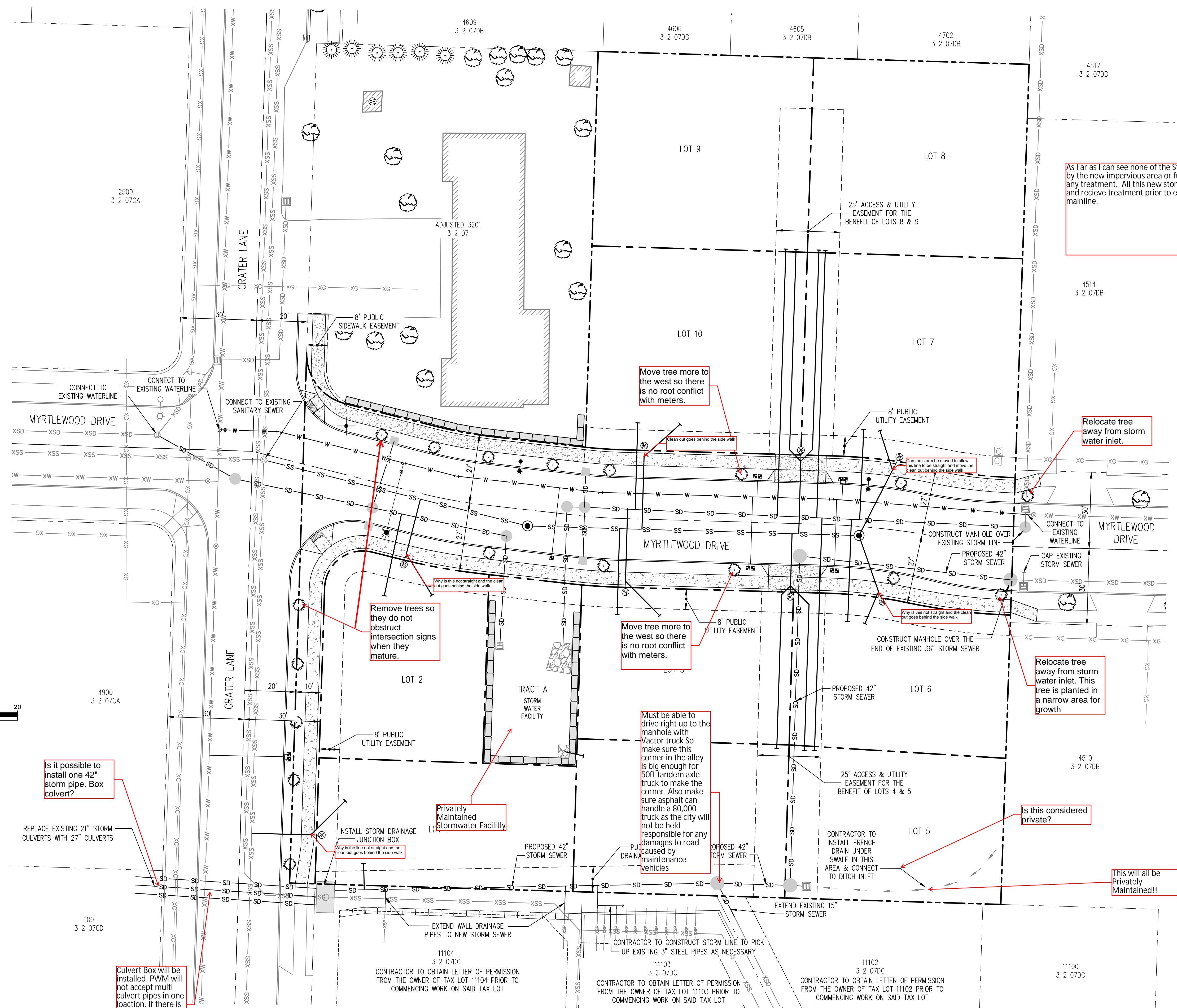

As Far as I can see none of the Stormwater that will be caught by the new impervious area or future home rain drains receives any treatment. All this new stormwater should be collected and receive treatment prior to entering the down stream public mainline.

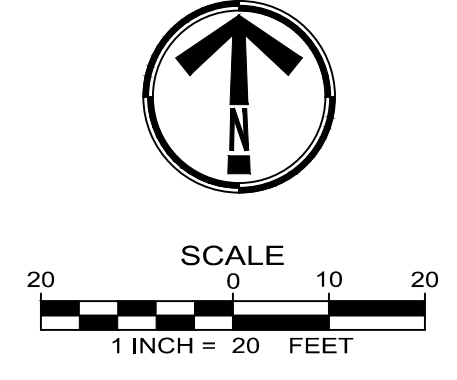

Is it possible to install one 42" storm pipe. Box culvert?

Culvert Box will be installed. PWM will not accept multi culvert pipes in one location. If there is any question if a culvert box can be used the answer is Yes.

Remove trees so they do not obstruct intersection signs when they mature.

Move tree more to the west so there is no root conflict with meters.

Move tree more to the west so there is no root conflict with meters.

Must be able to drive right up to the manhole with tractor truck So make sure this corner in the alley is big enough for 50ft tandem axle truck to make the corner. Also make sure asphalt can handle a 80,000 truck as the city will not be held responsible for any damages to road caused by maintenance vehicles

Relocate tree away from storm water inlet.

Relocate tree away from storm water inlet. This tree is planted in a narrow area for growth

Is this considered private?

This will all be Privately Maintained!!

PRELIMINARY SITE PLAT
SCALE: 1" = 20'

MYRTLEWOOD SUBDIVISION
A 10 LOT SUBDIVISION OF
ADJUSTED TAX LOT 3202
TAX MAP 3 2 07
CITY OF NEWBERG, OREGON

PRELIMINARY PLAT
PRELIMINARY SITE PLAN

NO.	DATE	DESCRIPTION

EMERIO
ENGINEERING • SURVEYING • DESIGN
6445 SW FALLBROOK PLACE, SUITE 100
BEAVERTON, OREGON 97008
TEL: (503) 746-9612
FAX: (503) 639-9892
www.emeriodesign.com

SHEET
4 OF 7

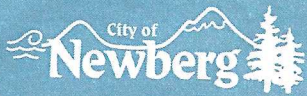

Community Development Planning Division
Land Use Application Referral

REFERRAL TO: TVFR , Deputy Fire Marshall, Ty Darby

The enclosed material has been referred to you for your information and comment. Any comments you wish to make should be returned to the Community Development Department prior to November 2, 2021. Please refer questions and comments to Doug Rux.

NOTE: Full size plans are available at the Community Development Department Office.

APPLICANT: Nick Daniken
REQUEST: 10 Lot residential subdivision in the low-density residential district.
SITE ADDRESS: 2900 N Crater Lane,
LOCATION: Newberg
TAX LOT: R3207 03202
FILE NO: SUB221-0002
ZONE: R-1

-
- Reviewed, no conflict.
 Reviewed; recommend denial for the following reasons:
 Require additional information to review. (Please list information required)
 Meeting requested.
 Comments. (Attach additional pages as needed)

Reviewed By:

DARBY / 0306

11/16/21
Date:



November 16, 2021

City of Newberg
Doug Rux
414 E. First St.
Newberg, OR 97132

Re: SUB221-0002, 2900 Crater Lane, 10 lot residential subdivision, Newberg, OR 97132

Dear Doug,

Thank you for the opportunity to review the proposed site plan surrounding the above-named development project. There may be more or less requirements needed based upon the final project design, however, Tualatin Valley Fire & Rescue will endorse this proposal predicated on the following criteria and conditions of approval:

1. **FIREFIGHTING WATER SUPPLY FOR INDIVIDUAL ONE- AND TWO-FAMILY DWELLINGS:** The minimum available fire flow for one and two-family dwellings served by a municipal water supply shall be 1,000 gallons per minute. If the structure(s) is (are) 3,600 square feet or larger, the required fire flow shall be determined according to OFC Appendix B. (OFC B105.2)
2. **FIRE FLOW WATER AVAILABILITY:** Applicants shall provide documentation of a fire hydrant flow test or flow test modeling of water availability from the local water purveyor if the project includes a new structure or increase in the floor area of an existing structure. Tests shall be conducted from a fire hydrant within 400 feet for commercial projects, or 600 feet for residential development. Flow tests will be accepted if they were performed within 5 years as long as no adverse modifications have been made to the supply system. Water availability information may not be required to be submitted for every project. (OFC Appendix B)
3. **FIRE HYDRANTS – ONE- AND TWO-FAMILY DWELLINGS & ACCESSORY STRUCTURES:** Where the most remote portion of a structure is more than 600 feet from a hydrant on a fire apparatus access road, as measured in an approved route around the exterior of the structure(s), on-site fire hydrants and mains shall be provided. (OFC 507.5.1)

If you have questions or need further clarification or would like to discuss any alternate methods and/or materials, please feel free to contact me at **(503)259-1409**.

Sincerely,

Ty Darby
Deputy Fire Marshal II



Community Development Planning Division
Land Use Application Referral

REFERRAL TO: Ziplly Fiber, Attn: Engineering

The enclosed material has been referred to you for your information and comment. Any comments you wish to make should be returned to the Community Development Department prior to November 2, 2021. Please refer questions and comments to Doug Rux.

NOTE: Full size plans are available at the Community Development Department Office.

APPLICANT: Nick Daniken
REQUEST: 10 Lot residential subdivision in the low-density residential district.
SITE ADDRESS: 2900 N Crater Lane,
LOCATION: Newberg
TAX LOT: R3207 03202
FILE NO: SUB221-0002
ZONE: R-1

-
- Reviewed, no conflict.
 Reviewed; recommend denial for the following reasons:
 Require additional information to review. (Please list information required)
 Meeting requested.
 Comments. (Attach additional pages as needed)

Reviewed By: SCOTT AUBERT ZIPLY FIBER

10/21/21
Date:

Doug Rux

From: EVANS Daniel * DSL <Daniel.EVANS@dsl.oregon.gov>
Sent: Friday, November 5, 2021 12:29 PM
To: ms@pacifichabitat.com
Cc: BLAUVELT Katie * DSL; DEBLASI Michael * DSL; Doug Rux; Nick Daniken
Subject: WD2021-0464 2900 Crater Lane, Newberg Wetland Delineation Review Questions

This email originated from outside the City of Newberg's organization. Do not click links or open attachments unless you recognize the sender and know the content is safe.

Hi Michael,

Thanks for submitting the 2900 Crater Lane Delineation in Newberg, Oregon. Based on the site photographs and recent Google Earth aerial images, it looks like you came into this project after substantial earth movement occurred. This makes a delineation report and consequently the review, much more difficult to complete. Currently there is insufficient levels of information provided in the report for DSL to make a concurrence. It may also be determined that a wetland removal-fill violation has occurred. The level of information in the report does not allow for a sufficient determination at this time. I'm copying DSL Resource Coordinators Katie Blauvelt (Yamhill County), Mike De Blasi (formerly Yamhill County), and Newberg Community Development Director Doug Rux so they are informed.

I would like to receive additional information, after which, Katie and I will discuss the possibility of a DSL site visit and/or if additional forensic delineation work is needed before continuing with the delineation review. Please embed replies in a different color.

Landscape Setting and Land Use

- Describe how the land was being used prior to the site grading. If being farmed what were the tilling, draining, disking, etc practices?
- What is the residential development planned for this site? Is it a subdivision?

Site Alteration-This delineation report is missing a great amount of detail regarding recent site alteration. Please provide a robust description for:

- When did construction grading and the site-wide vegetation removal occur? Is work still occurring?
- What occurred and where?
 - The field-How deep was soil disturbed during vegetation removal, were soils brought in or excavated?
 - Was the landscape graded?
 - Tributary A.-What was the bank profile before excavation activities occurred? V-shaped or a U-shaped trough?
 - Has it been widened and/or deepened?
 - Is there construction debris in the waters now? Something is visible in Google Earth.
 - Has erosion control been installed on the Tributary A cuts exposing bare earth on the sides and in the water?
- Are there any pre-construction photos available for anywhere across the site?
- Fully describe any additional construction grading or other activities that have occurred since the July 2021 site visit

Precipitation

- Data sheets describe hydrologic conditions as not normal at this time of year. Based on the antecedent rainfall data, DSL agrees with the data sheets in that regards. However, the report says “PHS believes that normal conditions for this site still prevailed even given the dryer than normal conditions”. Please clarify. What specific field determinations were made/not made because PHS determined that hydrology was normal.

Method

- Clarify how “the entire study area was investigated” in regard to the almost site-wide disturbance of soils and vegetation. Provide a robust description of why Plots 1 and 2 were chosen, the levels of disturbance within those plots (especially Plot 1-the data sheet is absent of information on disturbance information for a location that clearly has been cleared of vegetation and possibly has disturbed soils), and clarify why those should stand in as representative of uplands for the remainder of the site that looks to have been fully disturbed.
- Clarify how PHS characterizes the site vegetation as representative of “vegetation throughout the site”. Did you have other information about pre-disturbance conditions that hasn’t been shared to date?
- Clarify how dry season water table was tested for. The report describes testing to 20”. Plots 1-2 are only dug to 12”. Dry Season Water Table indicator requires digging to 24”.

Description of Wetlands/Waters

- Information on *specific OHWL indicators* to determine Tributary A extents is not included in the report. Please provide.
 - Explain how the boundaries were placed in the field, with a robust description of how the scraping, widening, and possibly deepening that is seen in the photo report, did not confound that determination. Approximately 160’ of the channel now appears as a steep sided trough devoid of most vegetation.
- What is the culvert size for Trib A on the east and west sides of the site?
- What are the sources of hydrology for Trib A? There was water moving through in July? Is this a perennial stream?
- PHS determined that Wetlands Below Ordinary High Water did not need mapping at this site. It appears from photos that the stream channel has had entire quantities of vegetation removed. Is it possible that the “vegetation <10% of the overall channel” only represents the immediate post-disturbance conditions and that conditions would be different following the first season of regrowth after the first wet season?
- What’s PHS thinking on how hydric soils formed at Plot 2, how far they may extend?
- A review of the 1995 Google Earth image indicates that the stream continued upgradient from the project site, and lines up with USGS 24k map topography showing a channel landform. DSL is presuming jurisdiction on Tributary A. Is there other information or review that was conducted to demonstrate otherwise? Was a historic aerial imagery search conducted going back to the 1930’s?

Thank you for your prompt attention to these questions.

Daniel Evans, PWS

Jurisdictional Coordinator

Columbia, Clatsop, Marion, Polk, Tillamook, Yamhill,

[Oregon Department of State Lands](#)

Desk: 503-986-5271 | Cell: 503-428-8188 | Fax: 503-378-4844

Attachment 2: Preliminary Plat

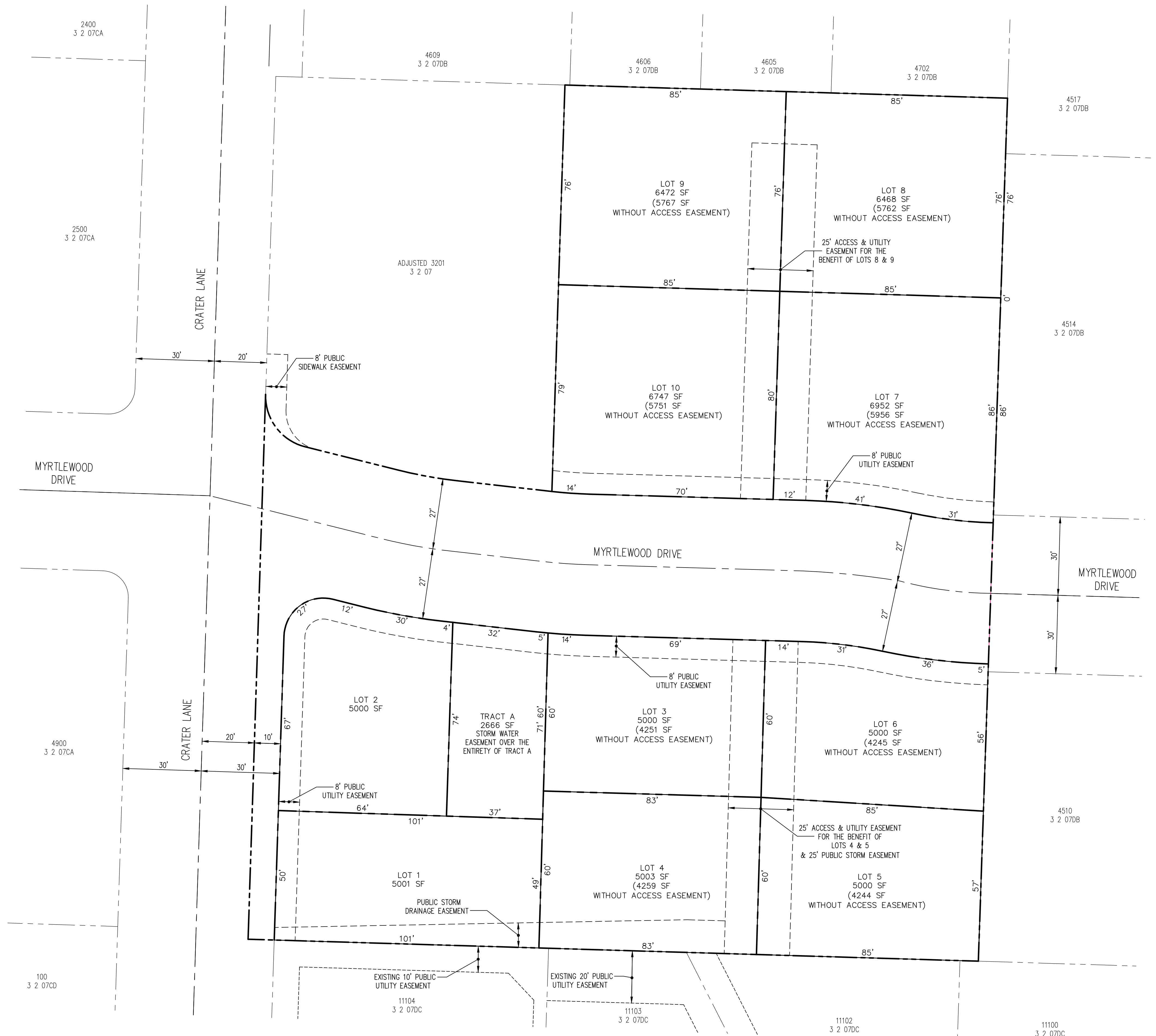
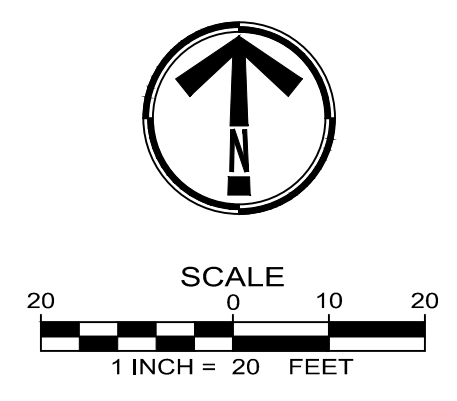

PRELIMINARY PLAT
SCALE: 1" = 20'

MYRTLEWOOD SUBDIVISION
A 10 LOT SUBDIVISION OF
ADJUSTED TAX LOT 3202
TAX MAP 3 2 07
CITY OF NEWBERG, OREGON

PRELIMINARY PLAT
PRELIMINARY PLAT

NO.	DATE	DESCRIPTION

EMERIO
ENGINEERING • SURVEYING • DESIGN
6445 SW FALLBROOK PLACE, SUITE 100
BEAVERTON, OREGON 97008
TEL: (503) 746-9812
FAX: (503) 639-9892
www.emeriodesign.com

SHEET
3
OF
7

Attachment 3: Application



TYPE II APPLICATION – LAND USE

File #: SEP 13 2021

TYPES – PLEASE CHECK ONE:

- Design review
- Tentative Plan for Partition
- Tentative Plan for Subdivision
- Type II Major Modification
- Variance
- Other: (Explain) _____

APPLICANT INFORMATION:

APPLICANT: Nick Daniken
 ADDRESS: 16869 SW 65th Ave Suite 115, Lake Oswego, OR 97035
 EMAIL ADDRESS: nick@greenwingpdx.com
 PHONE: _____ MOBILE: (541) 778-9333 FAX: _____
 OWNER (if different from above): Greenwing Restorations LLC PHONE: (503) 473 - 8870
 ADDRESS: 16869 SW 65th Ave Suite 115, Lake Oswego, OR 97035
 ENGINEER/SURVEYOR: Emerio Design PHONE: (503) 746 - 8812
 ADDRESS: 6445 SW Fallbrook Place Suite 100, Beaverton OR 97008

GENERAL INFORMATION:

PROJECT NAME: Myrtlewood Subdivision PROJECT LOCATION: Crater Lane
 PROJECT DESCRIPTION/USE: Subdivide for (10) NSFR PROJECT VALUATION: _____
 MAP/TAX LOT NO. (i.e.3200AB-400): R3207 03202 ZONE: _____ SITE SIZE: 1.74 SQ. FT. ACRE
 COMP PLAN DESIGNATION: R1 TOPOGRAPHY: Flat
 CURRENT USE: Raw Land
 SURROUNDING USES:
 NORTH: Single Family Homes SOUTH: Single Family Homes
 EAST: Single Family Homes WEST: Single Family Homes

SPECIFIC PROJECT CRITERIA AND REQUIREMENTS ARE ATTACHED

General Checklist: Fees Public Notice Information Current Title Report Written Criteria Response Owner Signature

For detailed checklists, applicable criteria for the written criteria response, and number of copies per application type, turn to:

- Design Reviewp. 12
- Partition Tentative Platp. 14
- Subdivision Tentative Platp. 17
- Variance Checklistp. 20

The above statements and information herein contained are in all respects true, complete, and correct to the best of my knowledge and belief. Tentative plans must substantially conform to all standards, regulations, and procedures officially adopted by the City of Newberg. All owners must sign the application or submit letters of consent. Incomplete or missing information may delay the approval process.

Nicholas Daniken 8/26/21
 Applicant Signature Date
Nicholas Daniken
 Print Name

JEFF T. EDWARDS, MANAGING MEMBER 08.26.21
 Owner Signature Date
JEFF T. EDWARDS, MANAGING MEMBER
 Print Name

EMERIO *Design*

CIVIL ENGINEERS & PLANNERS

DATE: 8-30-2021

PROPERTY OWNERS: Greenwing Restorations, LLC
16869 SW 65th Ave., Suite 115
Lake Oswego, OR 97035

**CIVIL ENGINEER,
PLANNING &
SURVEYOR:**

Emerio Design, LLC
Attn: Steve Miller
6445 SW Fallbrook Pl., Suite 100
Beaverton, OR 97008
Cell: (541) 318-7487
E-mail: stevem@emeriodesign.com

REQUEST: 10 Lot residential subdivision in the Low-Density Residential District (R-1). The proposal will be developed pursuant to the applicable criteria of the City of Newberg Municipal Code (NMC) requirements.

SITE

LOCATION: 2900 N Crater Ln.

ZONING: Low Density Residential District (R-1)

TOTAL

SITE SIZE: 76,006 Square Feet / 1.74 Acres

LEGAL DESCRIPTION: Tax Map 3-2-07; Tax Lot 3202

LIST OF EXHIBITS:

- 1 – Detailed Development Plans
- 2 – Yamhill Co Assessor Map
- 3 – Preliminary Storm Drainage Report
- 4 – Pre-Application Notes
- 5 – Title Report
- 6 – Neighborhood Mailing List and Labels

10-Lot Subdivision
Myrtlewood Subdivision

City of Newberg Municipal Code (NMC): The following sections of the Newberg Municipal Code are applicable to this land use approval:

- Chapter 15.235 – Land Divisions
 - Chapter 15.305 – Zoning Use Table
 - Chapter 15.405 – Lot Requirements
 - Chapter 15.410 – Yard Setback Requirements
 - Chapter 15.430 – Underground Utility Installation
 - Chapter 15.440 – Off Street Parking, Bicycle Parking, and Private Walkways
 - Chapter 15.505 – Public Improvement Standards
-

I. INTRODUCTION

The subject site is located at 2900 N Crater Ln. and is further identified on Yamhill County Assessor Map 3-2-07; Tax Lot 3202. The subject property is approximately 1.74 acres in size. The site area is generally oriented in a reverse "L" shape and is undeveloped. The site area is vegetated with a mix of trees, shrubs, and grass fields, and has an undulating topography. The subject site does not contain any flood plain or drainage hazard areas.

The applicant and property owner are requesting preliminary plat approval for a 10-Lot residential subdivision for single-family detached dwelling lots. The subject site is currently zoned Low Density Residential (R-1).

The subdivision will utilize the City's potable water, sanitary sewer and storm water services. The required number of street trees will be planted as part of the improvements. Storm water will be managed for the entire site via Tract A, which is the water quality detention/treatment facility to detain and treat storm water as per City standards.

2900 N CARTER LN. – VICINITY MAP

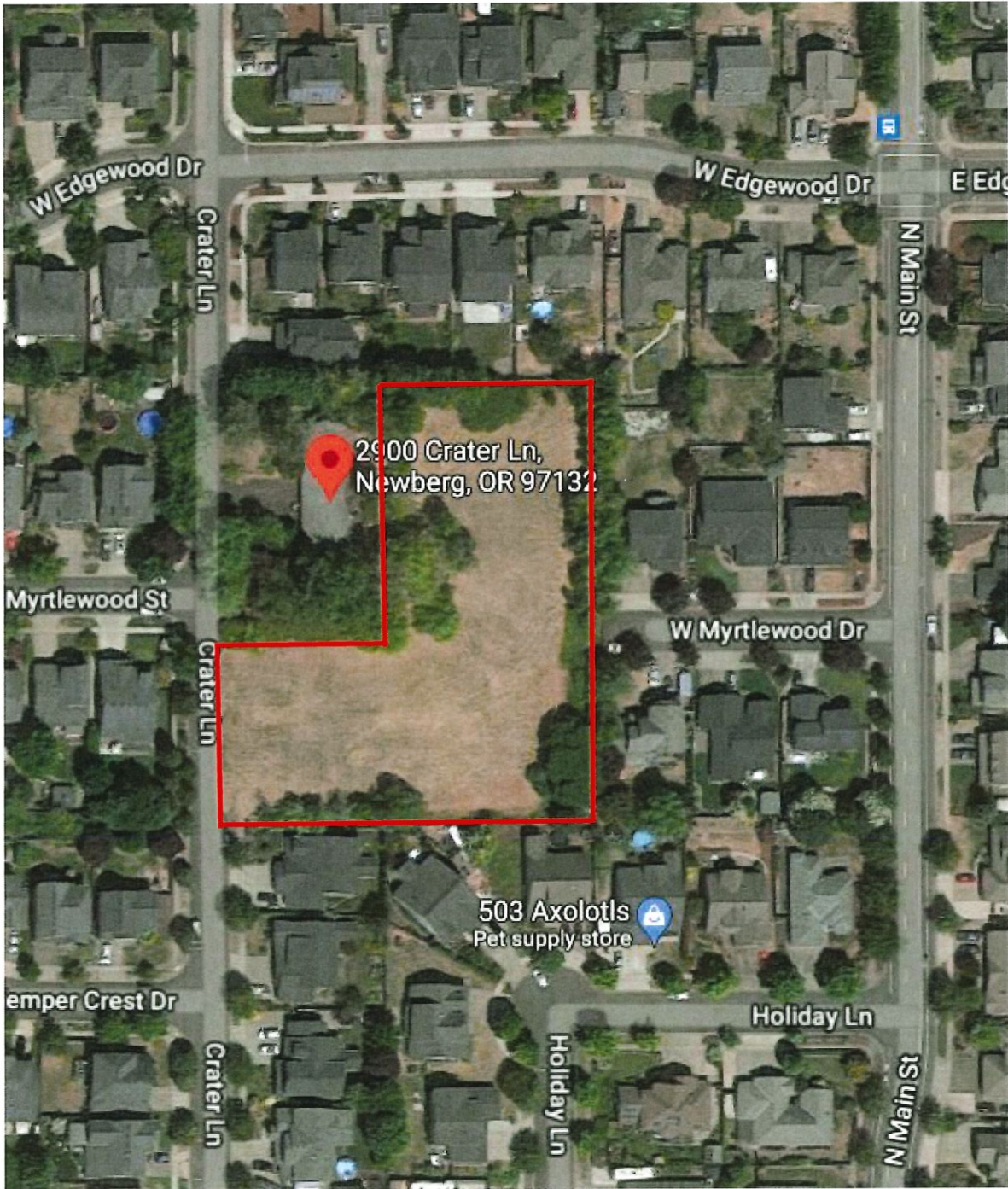

II. CONFORMANCE WITH CITY OF NEWBERG MUNICIPAL CODE (NMC) APPROVAL CRITERIA

**NEWBERG MUNICIPAL CODE (NMC)
Title 15 – DEVELOPMENT CODE**

10-Lot Subdivision
Myrtlewood Subdivision

Chapter 15.235 LAND DIVISIONS

15.235.050 Preliminary plat approval criteria

A. Approval Criteria. By means of a Type II procedure for a partition, or a Type II or III procedure for a subdivision per NMC 15.235.030(A), the applicable review body shall approve, approve with conditions, or deny an application for a preliminary plat. The decision shall be based on findings of compliance with all of the following approval criteria:

1. The land division application shall conform to the requirements of this chapter;

RESPONSE: The Applicant is proposing a 10-lot residential subdivision in the Low Density Residential District (R-1). As such, the Applicant has demonstrated through the submitted application materials and this narrative that the proposed subdivision conforms to the requirements of this chapter. Perceived

2. All proposed lots, blocks, and proposed land uses shall conform to the applicable provisions of NMC Division 15.400, Development Standards;

RESPONSE: See the Applicant's responses below under NMC Division 15.400, Development Standards.

3. Access to individual lots, and public improvements necessary to serve the development, including but not limited to water, wastewater, stormwater, and streets, shall conform to NMC Division 15.500, Public Improvement Standards;

RESPONSE: See the Applicant's responses below under NMC Division 15.500, Development Standards.

4. The proposed plat name is not already recorded for another subdivision, and satisfies the provisions of ORS Chapter 92;

RESPONSE: The Applicant is currently working with the Yamhill County Surveyor's office to reserve the "Myrtlewood" name for the proposed subdivision plat. As demonstrated through the submitted application materials and this narrative, the Applicant's proposed subdivision satisfies the provisions of ORS Chapter 92.

5. The proposed streets, utilities, and stormwater facilities conform to city of Newberg adopted master plans and applicable Newberg public works design and construction standards, and allow for transitions to existing and potential future development on adjacent lands. The preliminary plat shall identify all proposed public improvements and dedications;

RESPONSE: The Applicant's proposal satisfies the above criterion because the proposed

development will be extending Myrtlewood Dr., which is currently stubbed to the site's eastern property boundary, through the site to connect with Crater Lane. With the extension of Myrtlewood Dr., it will allow for transitions to existing and potential future development on surrounding lands. The proposed extension of Myrtlewood Dr. has been designed to conform to the City of Newberg adopted master plans and applicable Newberg public works standards.

In addition, the Applicant will also be dedicating additional right-of-way along the site's Crater Ln. frontage and making the necessary frontage improvements to comply with the City of Newberg public works design standards. Lastly, all proposed utility improvements and the proposed stormwater facilities conform to the City of Newberg public works design and construction standards. Sheets 4 and 5 of the submitted plan set provide additional detail demonstrating compliance with the City of Newberg design and construction standards for the proposed public improvements.

- 6. All proposed private common areas and improvements, if any, are identified on the preliminary [plat](#) and maintenance of such areas is assured through the appropriate legal instrument;**

RESPONSE: There are no proposed private common areas and/or improvements associated with the proposed development; therefore, the above criterion does not apply to the Applicant's proposal.

- 7. Evidence that any required state and federal permits, as applicable, have been obtained or can reasonably be obtained prior to development; and**
- 8. Evidence that improvements or conditions required by the [city](#), road authority, Yamhill County, special districts, [utilities](#), and/or other service providers, as applicable to the project, have been or can be met.**

RESPONSE: To the best of the Applicant's knowledge there are no required state and/or federal permits required for the proposed development. As part of the overall application submittal, the Applicant has provided detailed plans that show preliminary profiles & typical street sections, preliminary grading plan, and a preliminary site utility plan to demonstrate compliance with the City's road authority and utility requirements. To the best of the Applicant's knowledge, there are not special districts or Yamhill County code standards that apply to the Applicant's proposal. The Applicant's proposal satisfies the above criteria.

B. Conditions of Approval. The [city](#) may attach such conditions as are necessary to carry out provisions of this [code](#), and other applicable ordinances and regulations.

RESPONSE: The Applicant is aware of the above criterion and understands that the City may attach conditions of approval as are necessary to carry out the provisions of this code, as well as other applicable ordinances and regulations.

Chapter 15.305 ZONING USE TABLE

15.305.020 Zoning use table – Use districts.

Newberg Development Code – Zoning Use Table

#	Use	R-1	R-2	R-3	R-4	RP	C-1	C-2	C-3	C-4	M-1	M-2	M-3	M-4-I	M-4-C	CF	I	AR	AI	Notes and Special Use Standards
100	AGRICULTURAL USES																			
Def.	Horticulture	P	P	P(1)	P(1)	P(1)	P(1)	P(1)	P(1)	P(1)	P(1)	P(1)	P(1)	P(1)	P(1)	P(1)	P(1)	P(1)	P(1)	
Def.	Livestock and poultry farming	X	X	X	X	X	X	X	X	X	X	X	X	X	X	X	X	X	X	X
Def.	Home gardening	P	P	P	P	P	P	P	P	P	P	P	P	P	P	P	P	P	P	
Def.	Home livestock and poultry raising	S	S															S		NMC Title 6
200	RESIDENTIAL USES																			
Def.	Dwelling, single-family detached	P(2)	P	P(3)		P		C(4)	C(5)								P	P(6)		Subject to density limits of NMC 15.405.010(B)

RESPONSE: The subject property is zoned R-1, which is a low-density residential district. The Applicant is proposing a 10 Lot single-family residential subdivision, which is a permitted use in the R-1 Zone.

Chapter 15.405 LOT REQUIREMENTS

15.405.010 Lot area – Lot areas per dwelling unit.

A. In the following districts, each [lot](#) or [development site](#) shall have an area as shown below except as otherwise permitted by this code:

- 1. In the R-1 district, each lot or development site shall have a minimum area of 5,000 square feet or as may be established by a subdistrict. The average size of lots in a subdivision intended for single-family development shall not exceed 10,000 square feet.**

B. [Lot](#) or [Development Site](#) Area per [Dwelling Unit](#).

- 1. In the R-1 district, there shall be a minimum of 5,000 square feet per [dwelling unit](#).**

RESPONSE: As noted above, the subject property is located in the R-1 zoning district. The Applicant’s proposal satisfies the above criteria because all proposed lots are 5,000 sq. ft. in size or greater.

C. In calculating [lot](#) area for this section, [lot](#) area does not include land within public or [private streets](#). In calculating [lot](#) area for maximum [lot](#) area/minimum density requirements, [lot](#) area does not include land within [stream corridors](#), land reserved for public [parks](#) or [open spaces](#), commons [buildings](#), land for

preservation of natural, scenic, or historic resources, land on slopes exceeding 15 percent or for avoidance of identified natural hazards, land in shared [access](#) easements, [public walkways](#), or entirely used for [utilities](#), land held in reserve in accordance with a future [development plan](#), or land for [uses](#) not appurtenant to the residence.

RESPONSE: The Applicant has relied on the above criterion when calculating the lot area for each lot. The proposed lot areas do not include lands within public or private streets. Also, there are no stream corridors, land reserved for public parks or open spaces, commons buildings, land for preservation of natural, scenic, or historic resources, land on slopes exceeding 15 percent or for avoidance of identified natural hazards, public walkways, or entirely used for utilities, land held in reserve in accordance with a future development plan, or land for uses not appurtenant to the residence either located on the subject property or being proposed as part of this development proposal.

Lots 3 – 10 have land in shared access easements over these lots. The land located within the access easements of these lots has not be used in calculating lot area for these lots. Lots 3 – 6 are all 5,000 sq. ft. lots with the inclusion of the access and utility easements. After subtracting the square footage of the access and utility easement over these lots, though, these lots range in size between 4,244 sq. ft. to 4,259 sq. ft. in size. Lots 7 – 10 range in size from 6,468 sq. ft. to 6,952 sq. ft. with the inclusion of the access and utility easements. After subtracting the square footage of the access and utility easement over these lots, the lot sizes are as follows: Lot 7: 5,956 sq. ft., Lot 8: 5,762 sq. ft., Lot 9: 5,767 sq. ft., and Lot 10: 5,751 sq. ft. Lots 1 and 2 are not encumbered by an access easement and are both 5,000 sq. ft. in size or greater.

D. Lot size averaging is allowed for any subdivision. Some lots may be under the minimum lot size required in the zone where the subdivision is located, as long as the average size of all lots is at least the minimum lot size.

RESPONSE: Since the Newberg code does not allow for shared access easements to be included as part of the overall lot area when calculating lot sizes, the Applicant will be using the lot size averaging provided by the above criterion for the proposed subdivision. The Applicant is proposing the following lot sizes for the subdivision: Lot 1: 5,001 sq. ft., Lot 2: 5,000 sq. ft., Lot 3: 4,251 sq. ft., Lot 4: 4,259 sq. ft., Lot 5: 4,244 sq. ft., Lot 6: 4,245 sq. ft., Lot 7: 5,956 sq. ft., Lot 8: 5,762 sq. ft., Lot 9 5,767 sq. ft., and Lot 10: 5,751 sq. ft., for an average lot size of 5,023 sq. ft.

The Applicant's proposal satisfies the lot averaging criteria as the average lot size is at least the minimum lot size of 5,000 square feet as required by the R-1 zone.

15.405.030 Lot dimensions and frontage.

A. Width. Widths of [lots](#) shall conform to the standards of this [code](#).

RESPONSE: The Applicant's proposal satisfies the lot width standards of the R-1 zone as each lot has either frontage on a public street for a distance of at least 25 feet or has access to a public street through an easement that is at least 25 feet wide.

- B. Depth to Width Ratio.** Each lot and parcel shall have an average depth between the front and rear lines of not more than two and one-half times the average width between the side lines. Depths of lots shall conform to the standards of this code. Development of lots under 15,000 square feet are exempt from the lot depth to width ratio requirement.

RESPONSE: The above criterion does not apply to the applicant's proposal because all proposed lots are between 4,244 sq. ft. to 5,956 sq. ft., therefore, they are all under 15,000 sq. ft. in size and are exempt from the lot depth to width ratio requirement.

- C. Area.** Lot sizes shall conform to standards set forth in this code. Lot area calculations shall not include area contained in public or private streets as defined by this code.

RESPONSE: As noted above, the Applicant is utilizing the lot averaging criterion to satisfy the lot size requirements for the proposed subdivision. As such, the average lot size for the proposed 10 lot subdivision is 5,023 square feet, which meets the minimum lot size of the R-1 zone, and satisfies the above criterion.

D. Frontage.

1. No lot or development site shall have less than the following lot frontage standards:
 - a. Each lot or development site shall have either frontage on a public street for a distance of at least 25 feet or have access to a public street through an easement that is at least 25 feet wide. No new private streets, as defined in NMC 15.05.030, shall be created to provide frontage or access except as allowed by NMC 15.240.020(L)(2).
 - b. Each lot in R-2 zone shall have a minimum width of 25 feet at the front building line and R-3 zone shall have a minimum width of 30 feet at the front building line.
 - c. Each lot in R-1 zone shall have a minimum width of 35 feet at the front building line and AI or RP shall have a minimum width of 50 feet at the front building line.

RESPONSE: All proposed lots have a minimum frontage of 35 feet at the front building line, except for Lots 4, 5, 8, and 9, which have or have access to the public street through an easement that is at least 25 feet wide. All proposed lots will have a minimum width of 35 feet at the front building line. The Applicant's proposal satisfies the above criteria for new lots created in the R-1 zoning district.

15.405.040 Lot coverage and parking coverage requirements.

- B. Residential uses in residential zones shall meet the following maximum lot**

coverage and parking coverage standards. See the definitions in NMC 15.05.030 and Appendix A, Figure 4.

1. **Maximum Lot Coverage.**

a. R-1: 40 percent, or 50 percent if all structures on the lot are one story.

2. **Maximum Parking Coverage. R-1, R-2, R-3, and RP: 30 percent.**

RESPONSE: No new dwellings are being proposed at this time. Compliance with the lot coverage and parking coverage requirements will be reviewed during the building permit review process for the new dwellings.

Chapter 15.410 YARD SETBACK REQUIREMENTS

15.410.020 Front yard setback.

A. Residential (see Appendix A, Figure 10).

1. AR, R-1 and R-2 districts shall have a front yard of not less than 15 feet. Said yard shall be landscaped and maintained.

...

3. The entrance to a garage or carport, whether or not attached to a dwelling, shall be set back at least 20 feet from the nearest property line of the street to which access will be provided. However, the foregoing setback requirement shall not apply where the garage or carport will be provided with access to an alley only.

RESPONSE: No new dwellings are being proposed at this time. Compliance with the applicable setbacks will be reviewed during the building permit review process for the new dwellings.

15.410.030 Interior yard setback.

A. Residential.

1. All lots or development sites in the AR, R-1, R-2 and R-3 districts shall have interior yards of not less than five feet, except that where a utility easement is recorded adjacent to a side lot line, there shall be a side yard no less than the width of the easement.

RESPONSE: No new dwellings are being proposed at this time. Compliance with the applicable setbacks will be reviewed during the building permit review process for the new dwellings.

15.410.050 Special setback requirements to planned rights-of-way.

- B. Planned Street Right-of-Way Widths.** Planned street right-of-way widths are established as indicated in subsection (C) of this section for the various categories of streets shown in the transportation system plan.
- C. A lot or parcel of land in any district adjoining a street for which the planned right-of-way width and alignment have been determined shall have a building setback line equal to the yard required in the district, plus a distance of:**
1. Fifty feet from and parallel with the centerline of expressways.
 2. Thirty-five feet from and parallel with the centerline of major and minor arterials.
 3. Thirty feet from and parallel with the centerline of multifamily, commercial and industrial streets and single-family collector streets.
 4. Thirty feet from and parallel with the centerline of single-family local streets.
 5. Twenty-five feet from and parallel with the centerline of single-family hillside, cul-de-sacs and local streets which will never be extended more than 2,400 feet in length and which will have a relatively even division of traffic to two or more exits.

RESPONSE: Myrtlewood Dr. is currently stubbed to the site's eastern property boundary, and it is a street for which the planned right-of-way width and alignment have been determined. Myrtlewood Dr. between N. Main St. and Crater Ln. will be 530 feet in length and is a local street. Myrtlewood Dr. will never be extended more than 2,400 feet in length and will have a relatively even division of traffic to two exits. Thus, the lots adjoining Myrtlewood Dr. will have a building setback line equal to the yard required in the district plus a distance of twenty-five feet from and parallel with the centerline of Myrtlewood Dr. or criterion C(5) above.

15.410.060 Vision clearance setback.

The following vision clearance standards shall apply in all zones (see Appendix A, Figure 9).

- A. At the intersection of two streets, including private streets, a triangle formed by the intersection of the curb lines, each leg of the vision clearance triangle shall be a minimum of 50 feet in length.**
- B. At the intersection of a private drive and a street, a triangle formed by the intersection of the curb lines, each leg of the vision clearance triangle shall be a minimum of 25 feet in length.**
- C. Vision clearance triangles shall be kept free of all visual obstructions from two**

and one-half feet to nine feet above the [curb line](#). Where curbs are absent, the edge of the asphalt or future curb location shall be used as a guide, whichever provides the greatest amount of vision clearance.

RESPONSE: The required clear vision areas will be maintained at the following intersections: Myrtlewood Dr. and Crater Ln., as well as at the access easement intersections between Lots 3 and 6, and 7 and 10. The required clear vision setbacks will be shown at these intersections on the civil plans upon gaining land use approval. The vision clearance triangles will be kept free of all visual obstructions from two and one-half feet to nine feet above the curb line as required by the above criteria.

15.430.010 UNDERGROUND UTILITY INSTALLATION

- A. All new utility lines, including but not limited to electric, communication, natural gas, and cable television transmission lines, shall be placed underground. This does not include surface-mounted transformers, connections boxes, meter cabinets, service cabinets, temporary facilities during construction, and high-capacity electric lines operating at 50,000 volts or above.**
- B. Existing utility lines shall be placed underground when they are relocated, or when an addition or remodel requiring a Type II design review is proposed, or when a developed area is annexed to the [city](#).**

RESPONSE: The Applicant is proposing to install all new utility lines, including electric, communication, natural gas, and cable television transmission lines, underground as part of the proposed subdivision. Additionally, existing overhead utility lines serving the subject property will be placed underground to the extent practicable.

Chapter 15.440 OFF-STREET PARKING, BICYCLE PARKING, AND PRIVATE WALKWAYS

- A. Off-street parking shall be provided on the [development site](#) for all R-1, C-1, M-1, M-2 and M-3 zones. In all other zones, the required parking shall be on the [development site](#) or within 400 feet of the [development site](#) which the parking is required to serve. All required parking must be under the same ownership as the [development site](#) served except through special covenant agreements as approved by the [city](#) attorney, which bind the parking to the [development site](#).**
 - 1. In cases where the [applicant](#) is proposing off-street parking, refer to subsection (F) of this section for the maximum number of [parking spaces](#).**
- F. Maximum Number of Off-Street Automobile [Parking Spaces](#). The maximum number of off-street automobile [parking spaces](#) allowed per site equals the minimum number of required spaces, pursuant to NMC [15.440.030](#), multiplied by a factor of:**

1. One and one-fifth spaces for uses fronting a street with adjacent on-street parking spaces; or
2. One and one-half spaces for uses fronting no street with adjacent on-street parking

15.440.030 Parking spaces required.

<u>Use</u>	Minimum <u>Parking Spaces</u> Required
Residential Types	
<u>Dwelling, multifamily</u> and multiple <u>single-family dwellings</u> on a single <u>lot</u>	
Studio or one-bedroom unit	1 per <u>dwelling unit</u>
Two-bedroom unit	1.5 per <u>dwelling unit</u>
Three- and four-bedroom unit	2 per <u>dwelling unit</u>
Five- or more bedroom unit	0.75 spaces per bedroom
• Unassigned spaces	If a development is required to have more than 10 spaces on a <u>lot</u> , then it must provide some unassigned spaces. At least 15 percent of the total required <u>parking spaces</u> must be unassigned and be located for convenient <u>use</u> by all occupants of the development. The location shall be approved by the <u>director</u> .
• Visitor spaces	If a development is required to have more than 10 spaces on a <u>lot</u> , then it must provide at least 0.2 visitor spaces per <u>dwelling unit</u> .

RESPONSE: Based on the above criteria, the proposed subdivision will be required to provide a minimum of two (2) off street parking space per dwelling unit, as no five (5) bedroom houses are anticipated. Even though no houses are being proposed at this time, the proposed lot sizes will easily be able to accommodate two (2) car garages, as well as driveways capable of parking two (2) vehicles. Ultimate compliance with the off-street parking requirements will be reviewed during the building permit process. The Applicant's proposal satisfies the above criteria.

Chapter 15.505 PUBLIC IMPROVEMENTS STANDARDS

15.505.020 Applicability.

The provision and utilization of public facilities and services within the City of Newberg shall apply to all land developments in accordance with this chapter. No development shall be approved unless the following improvements are provided for prior to

occupancy or operation, unless future provision is assured in accordance with NMC [15.505.030\(E\)](#).

- A. Public Works Design and Construction Standards.** *The design and construction of all improvements within existing and proposed rights-of-way and [easements](#), all improvements to be maintained by the [city](#), and all improvements for which [city](#) approval is required shall comply with the requirements of the most recently adopted Newberg public works design and construction standards.*

RESPONSE: The Applicant is aware of the above requirements and understands that all proposed improvements within existing and proposed rights-of-ways and easements must comply with the requirements of the most recently adopted Newberg public works design and construction standards. The Applicant has provided detailed plans that demonstrate that all proposed public improvements can and will comply with the requirements of the most recently adopted Newberg public works design and construction standards. Nevertheless, ultimate compliance will be determined during the civil plan review upon gaining land use approval for the proposed subdivision.

- B. Street Improvements.** *All projects subject to a Type II design review, partition, or subdivision approval must construct street improvements necessary to serve the development.*

RESPONSE: The Applicant's proposal satisfies the above criterion because all proposed street improvements necessary to serve the proposed subdivision will be constructed with the development.

- C. Water.** *All developments, [lots](#), and [parcels](#) within the [City](#) of Newberg shall be served by the municipal water system as specified in Chapter [13.15](#) NMC.*
- D. Wastewater.** *All developments, [lots](#), and [parcels](#) within the [City](#) of Newberg shall be served by the municipal wastewater system as specified in Chapter [13.10](#) NMC.*
- E. Stormwater.** *All developments, [lots](#), and [parcels](#) within the [City](#) of Newberg shall manage stormwater runoff as specified in Chapters [13.20](#) and [13.25](#) NMC.*
- F. Utility [Easements](#).** *Utility [easements](#) shall be provided as necessary and required by the review body to provide needed facilities for present or future development of the area.*
- G. [City](#) Approval of Public Improvements Required.** *No [building](#) permit may be issued until all required public facility improvements are in place and approved by the [director](#), or are otherwise bonded for in a manner approved by the review authority, in conformance with the provisions of this [code](#) and the Newberg Public Works Design and Construction Standards.*

RESPONSE: The Applicant's proposal satisfies the above criteria because all proposed lots will be served by municipal water, wastewater, and stormwater systems as required

by Newberg code. Additionally, the necessary utility easements have been provided as necessary to provide the needed facilities for the development.

Upon gaining land use approval for the proposed subdivision, the Applicant will be submitting detailed civil plans to the City's Public Works Dept. for approval of the proposed public improvements. The Applicant understands that no building permits will be issued until all required public facility improvements are in place and approved by the City or are otherwise bonded for in a manner approved by the City.

15.505.030 Street standards.

- C. *Layout of Streets, Alleys, Bikeways, and Walkways. Streets, alleys, bikeways, and walkways shall be laid out and constructed as shown in the Newberg transportation system plan. In areas where the transportation system plan or future street plans do not show specific transportation improvements, roads and streets shall be laid out so as to conform to previously approved subdivisions, partitions, and other developments for adjoining properties, unless it is found in the public interest to modify these patterns. Transportation improvements shall conform to the standards within the Newberg Municipal Code, the Newberg public works design and construction standards, the Newberg transportation system plan, and other adopted city plans.***

RESPONSE: The Applicant's proposal satisfies the above criterion because the proposed layout of streets, alleys, bikeways and walkways are laid out and will be constructed as shown in the Newberg transportation system plan. As part of the proposed subdivision, Myrtlewood Dr. will be extended west through the site to connect with Crater Ln. as anticipated in the Newberg transportation system plan. In addition, a 10-foot right-of-way dedication is proposed for Crater Ln. to widen the street as expected by the Newberg transportation system plan. Lastly, the proposed access easements (i.e. alleys) will be designed and constructed to the Newberg public works design and construction standards.

- D. *Construction of New Streets. Where new streets are necessary to serve a new development, subdivision, or partition, right-of-way dedication and full street improvements shall be required. Three-quarter streets may be approved in lieu of full street improvements when the city finds it to be practical to require the completion of the other one-quarter street improvement when the adjoining property is developed; in such cases, three-quarter street improvements may be allowed by the city only where all of the following criteria are met:***

- 1. *The land abutting the opposite side of the new street is undeveloped and not part of the new development; and***
- 2. *The adjoining land abutting the opposite side of the street is within the city limits and the urban growth boundary.***

RESPONSE: As part of the proposed subdivision, the Applicant is proposing to dedicate right-of-way and make full street improvements for the extension of Myrtlewood Dr.

through the site. In addition, the Applicant is proposing to make a 10-foot right-of-way dedication for Crater Ln. so it can be improved to the full width adjacent to the subject site. The Applicant's proposal satisfies the above criterion.

E. Improvements to Existing Streets.

- 1. All projects subject to partition, subdivision, or Type II design review approval shall dedicate right-of-way sufficient to improve the street to the width specified in subsection (G) of this section.**
- 2. All projects subject to partition, subdivision, or Type II design review approval must construct a minimum of a three-quarter street improvement to all existing streets adjacent to, within, or necessary to serve the development. The director may waive or modify this requirement where the applicant demonstrates that the condition of existing streets to serve the development meets city standards and is in satisfactory condition to handle the projected traffic loads from the development. Where a development has frontage on both sides of an existing street, full street improvements are required.**

RESPONSE: As noted previously, the Applicant is proposing a 10-foot right-of-way dedication for Crater Ln., which is sufficient to improve the width of Crater Ln. adjacent to the subject site. The proposed right-of-way dedication and associated improvements to Crater Ln. will allow the existing street adjacent to the site to serve the proposed development. The Applicant's proposal satisfies the above criterion.

F. Improvements Relating to Impacts. Improvements required as a condition of development approval shall be roughly proportional to the impact of the development on public facilities and services. The review body must make findings in the development approval that indicate how the required improvements are roughly proportional to the impact. Development may not occur until required transportation facilities are in place or guaranteed, in conformance with the provisions of this code. If required transportation facilities cannot be put in place or be guaranteed, then the review body shall deny the requested land use application.

RESPONSE: The Applicant's proposal satisfies the above criterion because all proposed improvements relating to the anticipated impacts associated with the proposed subdivision are roughly proportional to the impacts of the development on public facilities and services. The Applicant will be extending Myrtlewood Dr. through the site to connect with Crater Ln., extending public and private utilities to all lots, dedicating 10-feet of right-of-way along the sites Crater Ln. frontage and making required frontage improvement, and a stormwater facility will be located in Tract A.

G. Street Width and Design Standards.

- 1. Design Standards. All streets shall conform with the standards contained in Table 15.505.030(G). Where a range of values is listed, the director shall determine the width based on a consideration of the total street section width**

needed, existing street widths, and existing development patterns. Preference shall be given to the higher value. Where values may be modified by the director, the overall width shall be determined using the standards under subsections (G)(2) through (10) of this section.

Table 15.505.030(G) Street Design Standards

Type of <u>Street</u>	<u>Right-of-Way</u> Width	Curb-to-Curb Pavement Width	Motor Vehicle Travel Lanes	Median Type	Striped <u>Bike Lane</u> (Both Sides)	On-Street Parking
Arterial Streets						
Expressway**	<u>ODOT</u>	<u>ODOT</u>	<u>ODOT</u>	<u>ODOT</u>	<u>ODOT</u>	<u>ODOT</u>
<u>Major arterial</u>	95 - 100 feet	74 feet	4 lanes	TWLTL or median*	Yes	No*
<u>Minor arterial</u>	69 - 80 feet	48 feet	2 lanes	TWLTL or median*	Yes	No*
Collectors						
Major	57 - 80 feet	36 feet	2 lanes	None*	Yes	No*
Minor	61 - 65 feet	40 feet	2 lanes	None*	Yes*	Yes*
Local Streets						
Local residential	54 - 60 feet	32 feet	2 lanes	None	No	Yes
Limited residential, parking both sides	44 - 50 feet	28 feet	2 lanes	None	No	Yes
Limited residential, parking one side	40 - 46 feet	26 feet	2 lanes	None	No	One side
Local commercial/ industrial	55 - 65 feet	34 feet	2 lanes	None*	No*	Yes*

RESPONSE: Myrtlewood Drive is designated as a "local residential" street. As part of the proposed subdivision, the Applicant is proposing to extend Myrtlewood Dr. through the site in a 54-foot-wide right-of-way, with a curb to curb pavement width of 34 ½ - feet. In

addition, the Applicant is proposing a 10 – foot right-of-way dedication along the sites Crater Ln. frontage, which will increase the Crater Ln. right-of-way to 30-feet adjacent to the site. Crater Ln. will also be improved with 9-feet of pavement to provide a 16-foot-wide travel lane along the sites Crater Ln. frontage. See Sheet 5, Preliminary Profiles & Typical Street Sections, for more detail. The Applicant's proposal satisfies the above criterion.

2. **Motor Vehicle Travel Lanes.** Collector and arterial streets shall have a minimum width of 12 feet.
3. **Bike Lanes.** Striped bike lanes shall be a minimum of six feet wide. Bike lanes shall be provided where shown in the Newberg transportation system plan.
4. **Parking Lanes.** Where on-street parking is allowed on collector and arterial streets, the parking lane shall be a minimum of eight feet wide.
5. **Center Turn Lanes.** Where a center turn lane is provided, it shall be a minimum of 12 feet wide.

RESPONSE: The above criteria do not apply to the Applicant's proposal because the site does not abut a collector or arterial street.

6. **Limited Residential Streets.** Limited residential streets shall be allowed only at the discretion of the review authority, and only in consideration of the following factors:
 - a. The requirements of the fire chief shall be followed.
 - b. The estimated traffic volume on the street is low, and in no case more than 600 average daily trips.
 - c. Use for through streets or looped streets is preferred over cul-de-sac streets.
 - d. Use for short blocks (under 400 feet) is preferred over longer blocks.
 - e. The total number of residences or other uses accessing the street in that block is small, and in no case more than 30 residences.
 - f. On-street parking usage is limited, such as by providing ample off-street parking, or by staggering driveways so there are few areas where parking is allowable on both sides.

RESPONSE: The Applicant is proposing to extend Myrtlewood St. through the site (approximately 270-feet) to connect with Crater Ln. With the proposed extension of Myrtlewood Dr. through the site it will connect N. Main St. with Crater Ln., which is

approximately 530-foot centerline to centerline. Due to existing development in the area, it is not possible for the Applicant reduce the block length by stubbing a new local street to the north or south as the existing homes preclude any future street connections. As such, the proposed block length is the minimum necessary to connect Myrtlewood St. with Crater Ln. and complete the block between N. Main St. and Crater Ln. With the extension of Myrtlewood Dr. through the site, there will be a total of 15 residences accessing the street in the block, which includes the six (6) existing residences currently accessing Myrtlewood Dr. east of the subject property. All proposed lots will be able to provide a minimum of two (2) off-street parking spaces, which will help to limit on-street parking. The Applicant's proposal satisfies the above criteria.

7. **Sidewalks. Sidewalks shall be provided on both sides of all public streets. Minimum width is five feet.**
8. **Planter Strips. Except where infeasible, a planter strip shall be provided between the sidewalk and the curb line, with a minimum width of five feet. This strip shall be landscaped in accordance with the standards in NMC 15.420.020. Curb-side sidewalks may be allowed on limited residential streets. Where curb-side sidewalks are allowed, the following shall be provided:**
 - a. **Additional reinforcement is done to the sidewalk section at corners.**
 - b. **Sidewalk width is six feet.**
9. **Slope Easements. Slope easements shall be provided adjacent to the street where required to maintain the stability of the street.**
10. **Intersections and Street Design. The street design standards in the Newberg public works design and construction standards shall apply to all public streets, alleys, bike facilities, and sidewalks in the city.**
11. **The planning commission may approve modifications to street standards for the purpose of ingress or egress to a minimum of three and a maximum of six lots through a conditional use permit.**

RESPONSE: Five-foot wide sidewalks and 5-foot-wide planter strips will be provided on both sides of Myrtlewood Dr. for the section of the street extended through the subject property. In addition, a 5-foot sidewalk and a 5-foot-wide planter strip will be added to the sites Crater Ln. frontage. No slope easements are necessary for the proposed subdivision. See Sheet 5, Preliminary Profiles & Typical Street Sections, for more detail.

- K. **Future Extension of Streets. All new streets required for a subdivision, partition, or a project requiring site design review shall be constructed to be "to and through": through the development and to the edges of the project site to serve adjacent properties for future development.**

L. Cul-de-Sacs.

RESPONSE: The Applicant is proposing to extend the currently stubbed portion of Myrtlewood Dr. to and through the site so it can connect with Crater Ln. No other streets are required or necessary to serve future development as all surrounding property has been developed. Additionally, no cul-de-sacs are being proposed. The Applicant's proposal satisfies the above criteria.

M. Street Names and Street Signs. *Streets that are in alignment with existing named streets shall bear the names of such existing streets. Names for new streets not in alignment with existing streets are subject to approval by the director and the fire chief and shall not unnecessarily duplicate or resemble the name of any existing or platted street in the city. It shall be the responsibility of the land divider to provide street signs.*

RESPONSE: As noted previously, the Applicant will be extending an existing street, Myrtlewood Dr., to and through the site to connect with Crater Ln. The existing street name will continue to be used for the street extension. No other streets are being proposed.

N. Platting Standards for Alleys.

RESPONSE: No alleys are being proposed; therefore, this criterion does not apply to the Applicant's proposal.

O. Platting Standards for Blocks.

- 1. Purpose. Streets and walkways can provide convenient travel within a neighborhood and can serve to connect people and land uses. Large, uninterrupted blocks can serve as a barrier to travel, especially walking and biking. Large blocks also can divide rather than unite neighborhoods. To promote connected neighborhoods and to shorten travel distances, the following minimum standards for block lengths are established.**
- 2. Maximum Block Length and Perimeter. The maximum length and perimeters of blocks in the zones listed below shall be according to the following table. The review body for a subdivision, partition, conditional use permit, or a Type II design review may require installation of streets or walkways as necessary to meet the standards below.**

Zone(s)	Maximum Block Length	Maximum Block Perimeter
R-1	800 feet	2,000 feet
R-2, R-3, RP, I	1,200 feet	3,000 feet

4. **Public Pedestrian Walkways and Bicycle Access.** The approval authority in approving a land use application with conditions may require a developer to provide an access way where the creation of a street consistent with street spacing standards is infeasible and the creation of a cul-de-sac or dead-end street is unavoidable. A public walkway provides a connection through a block that is longer than established standards or connects the end of the street to another right-of-way or a public access easement. A public walkway shall be contained within a public right-of-way or public access easement, as required by the city. A public walkway shall be a minimum of 10 feet wide and shall provide a minimum six-foot-wide paved surface or other all-weather surface approved by the city (see subsection (S) of this section for public walkway standards).

Design features should be considered that allow access to emergency vehicles but that restrict access to non-emergency motorized vehicles.

RESPONSE: Due to existing residential development surrounding the subject property, the block lengths in the vicinity of the subject property have been predetermined. With the extension of Myrtlewood Dr. through the subject property, it will complete the block consisting of W Edgewood Dr. (norther boundary), N Main St. (eastern boundary), Myrtlewood Dr. (southern boundary), and Crater Ln. (west boundary). The block length and perimeter block distances are as follows: W Edgewood Dr. to Myrtlewood Dr. along N Main St. is 340-feet, Myrtlewood Dr. between N Main St. and Crater Ln. is 534-feet, Myrtlewood Dr. to W Edgewood Dr. along Crater Ln. is 330-feet, and Crater Ln. to N. Main St. along W Edgewood Dr. is 534-feet for a total perimeter block length of 1,737 feet. The existing streets and walkways, together with the proposed extension of Myrtlewood Dr. through the site, will create block lengths consistent with the above criteria and will provide convenient travel within the neighborhood to connect people and surrounding land uses.

- P. **Private Streets.** New private streets, as defined in NMC 15.05.030, shall not be created, except as allowed by NMC 15.240.020(L)(2).

RESPONSE: No private streets are being proposed as part of this development proposal. Even though there will be easements serving some of the proposed lots, the easements will not be classified as private streets. The above criterion does not apply to the Applicant's proposal.

Q. Traffic Calming.

RESPONSE: No traffic calming measures are required or necessary for the proposed subdivision, therefore, the above criterion does not apply to the Applicant's proposal.

R. Vehicular Access Standards.

1. **Purpose.** The purpose of these standards is to manage vehicle access to maintain traffic flow, safety, roadway capacity, and efficiency. They help to

maintain an adequate level of service consistent with the functional classification of the street. Major roadways, including arterials and collectors, serve as the primary system for moving people and goods within and through the city. Access is limited and managed on these roads to promote efficient through movement. Local streets and alleys provide access to individual properties. Access is managed on these roads to maintain safe maneuvering of vehicles in and out of properties and to allow safe through movements. If vehicular access and circulation are not properly designed, these roadways will be unable to accommodate the needs of development and serve their transportation function.

- 2. Access Spacing Standards. Public street intersection and driveway spacing shall follow the standards in Table 15.505.R below. The Oregon Department of Transportation (ODOT) has jurisdiction of some roadways within the Newberg city limits, and ODOT access standards will apply on those roadways.*

RESPONSE: The subject property does not abut an arterial or collector street, so the vehicular access standards for those street classifications do not apply to this proposal.

Because some of the proposed lots will be taking access from a shared access easement (i.e. Lots 3 – 6 and 7 – 10), driveway spacing along Myrtlewood Dr. will be limited to only two (2) total driveways (i.e. easements serving Lots 3 – 6 and 7 – 10). The only other driveway on Myrtlewood Dr. will be for the water quality facility in Tract A. Lots 1 and 2 will take access from Crater Ln. Myrtlewood Dr. and Crater Ln. are designated as local public streets and the proposed driveway spacing follows the standards listed in Table 15.505 R. The Applicant's proposal satisfies the driveway spacing standards for a local public street.

- 3. Properties with Multiple Frontages. Where a property has frontage on more than one street, access shall be limited to the street with the lesser classification.*
- 4. Driveways. More than one driveway is permitted on a lot accessed from either a minor collector or local street as long as there is at least 40 feet of lot frontage separating each driveway approach. More than one driveway is permitted on a lot accessed from a major collector as long as there is at least 100 feet of lot frontage separating each driveway approach.*
- 5. Alley Access. Where a property has frontage on an alley and the only other frontages are on collector or arterial streets, access shall be taken from the alley only. The review body may allow creation of an alley for access to lots that do not otherwise have frontage on a public street provided all of the following are met:*

RESPONSE: Except for Lot 2, which is a corner lot, no other lots have multiple frontages. Lot 2 will take access from Crater Ln. as it will not be able to meet the spacing

standards from the new intersection of Myrtlewood Dr. and Crater Ln. Shared driveways (i.e. easement) is proposed for Lots 3 – 6 and 7 – 10.

- 6. Closure of Existing Accesses. Existing accesses that are not used as part of development or redevelopment of a property shall be closed and replaced with curbing, sidewalks, and landscaping, as appropriate.**

RESPONSE: The above criterion does not apply to the Applicant's proposal because closure of an existing access is not being proposed as part of this development proposal.

7. Shared Driveways.

- a. The number of driveways onto arterial streets shall be minimized by the use of shared driveways with adjoining lots where feasible. The city shall require shared driveways as a condition of land division or site design review, as applicable, for traffic safety and access management purposes. Where there is an abutting developable property, a shared driveway shall be provided as appropriate. When shared driveways are required, they shall be stubbed to adjacent developable parcels to indicate future extension. "Stub" means that a driveway temporarily ends at the property line, but may be accessed or extended in the future as the adjacent parcel develops. "Developable" means that a parcel is either vacant or it is likely to receive additional development (i.e., due to infill or redevelopment potential).**

RESPONSE: The above criterion does not apply to the Applicant's proposal because the subject property does not abut an arterial street; therefore, no driveways will have access to a street classified as an arterial.

- b. Access easements (i.e., for the benefit of affected properties) and maintenance agreements shall be recorded for all shared driveways, including pathways, at the time of final plat approval or as a condition of site development approval.**
- c. No more than four lots may access one shared driveway.**
- d. Shared driveways shall be posted as no parking fire lanes where required by the fire marshal.**
- e. Where three lots or three dwellings share one driveway, one additional parking space over those otherwise required shall be provided for each dwelling. Where feasible, this shall be provided as a common use parking space adjacent to the driveway.**

RESPONSE: Access easements are proposed for lots 3 – 6 and 7 – 10 and no more than four (4) lots will have access from the shared driveways. The proposed shared driveways will be posted as "no parking fire lanes" as required by the fire marshal.

Lastly, because the proposed shared access easements will serve four (4) lots each, one (1) additional parking space over those otherwise required will be provided for each dwelling. Where feasible, this will be provided as a common use parking space adjacent to the driveway. The Applicant's proposal satisfies the above criteria.

- 8. Frontage Streets and Alleys. The review body for a partition, subdivision, or design review may require construction of a frontage street to provide access to properties fronting an arterial or collector street.**

RESPONSE: The above criterion does not apply to the Applicant's proposal because the subject property does not abut an arterial or collector street; therefore, no frontage street or alley is necessary.

- 9. ODOT or Yamhill County Right-of-Way. Where a property abuts an ODOT or Yamhill County right-of-way, the applicant for any development project shall obtain an access permit from ODOT or Yamhill County.**

- 10. Exceptions. The director may allow exceptions to the access standards above in any of the following circumstances:**

RESPONSE: The above criteria do not apply to the Applicant's proposal because the subject property does not abut an ODOT or Yamhill County right-of-way; therefore, an access permit from these jurisdictions is not required.

S. Public Walkways.

- 1. Projects subject to Type II design review, partition, or subdivision approval may be required to provide public walkways where necessary for public safety and convenience, or where necessary to meet the standards of this code. Public walkways are meant to connect cul-de-sacs to adjacent areas, to pass through oddly shaped or unusually long blocks, to provide for networks of public paths according to adopted plans, or to provide access to schools, parks or other community destinations or public areas. Where practical, public walkway easements and locations may also be used to accommodate public utilities.**
- 2. Public walkways shall be located within a public access easement that is a minimum of 15 feet in width.**
- 3. A walk strip, not less than 10 feet in width, shall be paved in the center of all public walkway easements. Such paving shall conform to specifications in the Newberg public works design and construction standards.**
- 4. Public walkways shall be designed to meet the Americans with Disabilities Act requirements.**
- 5. Public walkways connecting one right-of-way to another shall be designed to provide as short and straight of a route as practical.**

6. **The developer of the public walkway may be required to provide a homeowners' association or similar entity to maintain the public walkway and associated improvements.**
7. **Lighting may be required for public walkways in excess of 250 feet in length.**
8. **The review body may modify these requirements where it finds that topographic, preexisting development, or similar constraints exist.**

RESPONSE: The above criteria do not apply to the Applicant's proposal because no cul-de-sacs are being proposed which would require a "public walkway" to connect to adjacent areas. Additionally, a "public walkway" is not needed for the project to allow pass through of oddly shaped or unusually long blocks, to provide for networks of public paths according to adopted City plans, or to provide access to schools, parks or other community destinations or public areas. With that being said, the proposed extension of Myrtlewood Dr. through the site will include sidewalks on both sides of the street, as well as a new sidewalk along the sites Crater Ln. frontage.

- T. **Street Trees. Street trees shall be provided for all projects subject to Type II design review, partition, or subdivision. Street trees shall be installed in accordance with the provisions of NMC 15.420.010(B)(4).**

RESPONSE: The Applicant's proposal satisfies the above criterion because the submitted plans show street trees will be installed on both sides of the Myrtlewood Dr. street extension through the site, as well as along the sites Crater Ln. street frontage. All proposed street trees will be installed in accordance with the provisions of NMC 15.420.010(B)(4).

- U. **Street Lights. All developments shall include underground electric service, light standards, wiring and lamps for street lights according to the specifications and standards of the Newberg public works design and construction standards. The developer shall install all such facilities and make the necessary arrangements with the serving electric utility as approved by the city. Upon the city's acceptance of the public improvements associated with the development, the street lighting system, exclusive of utility-owned service lines, shall be and become property of the city unless otherwise designated by the city through agreement with a private utility.**

RESPONSE: As required by the above criterion, the proposed development will include underground electric service, light standards, wiring and lamps for streetlights in accordance with the specifications and standards of the Newberg public works design and construction standards. All required streetlights will be installed in the public right-of-way and will become property of the City upon the City's acceptance of the public improvements associated with the development.

- V. **Transit Improvements. Development proposals for sites that include or are adjacent to existing or planned transit facilities, as shown in the Newberg**

transportation system plan or adopted local or regional transit plan, shall be required to provide any of the following, as applicable and required by the review authority:

RESPONSE: The above criterion does not apply to the Applicant's proposal because the subject property is not located adjacent to an existing or planned transit facility, as shown in the Newberg Transportation System Plan (TSP) or adopted local or regional transit plans.

15.505.040 Public utility standards.

C. General Standards.

- 1. The design and construction of all improvements within existing and proposed rights-of-way and easements, all improvements to be maintained by the city, and all improvements for which city approval is required shall conform to the Newberg public works design and construction standards and require a public improvements permit.**
- 2. The location, design, installation and maintenance of all utility lines and facilities shall be carried out with minimum feasible disturbances of soil and site. Installation of all proposed public and private utilities shall be coordinated by the developer and be approved by the city to ensure the orderly extension of such utilities within public right-of-way and easements.**

RESPONSE: All proposed and required improvements within the existing and proposed rights-of-ways will be designed and constructed conform to the Newberg public works design and construction standards. Upon gaining land use approval for the proposed subdivision, the Applicant will submit detailed civil plans to the City's Public Works department for review and approval in order to obtain a public improvements permit.

Additionally, the location, design, installation and maintenance of all required utility lines and facilities will be done with minimum disturbances of the soils and the site. Installation of all required public and private utilities will be coordinated by the developer and approved by the city to ensure the extension of such utilities within public right-of-way and easements are done in an organized fashion.

D. Standards for Water Improvements. All development that has a need for water service shall install the facilities pursuant to the requirements of the city and all of the following standards. Installation of such facilities shall be coordinated with the extension or improvement of necessary wastewater and stormwater facilities, as applicable.

- 1. All developments shall be required to be linked to existing water facilities adequately sized to serve their intended area by the construction of water distribution lines, reservoirs and pumping stations which connect to such water service facilities. All necessary easements required for the construction of these facilities shall be obtained by the developer and granted to**

the [city](#) pursuant to the requirements of the [city](#).

2. Specific location, size and capacity of such facilities will be subject to the approval of the [director](#) with reference to the applicable water master plan. All water facilities shall conform with [city](#) pressure zones and shall be looped where necessary to provide adequate pressure and fire flows during peak demand at every point within the system in the development to which the water facilities will be connected. Installation costs shall remain entirely the developer's responsibility.
3. The design of the water facilities shall take into account provisions for the future extension beyond the development to serve adjacent properties, which, in the judgment of the [city](#), cannot be feasibly served otherwise.
4. Design, construction and material standards shall be as specified by the [director](#) for the construction of such public water facilities in the [city](#).

RESPONSE: All proposed water improvements have been designed pursuant to the requirements of the City and the above standards. Upon gaining land use approval for the proposed subdivision, the Applicant will be submitting detailed civil plans to the City's Public Works department to further demonstrate compliance with the applicable City requirements for the installation of the water facilities.

E. Standards for Wastewater Improvements. All development that has a need for wastewater services shall install the facilities pursuant to the requirements of the [city](#) and all of the following standards. Installation of such facilities shall be coordinated with the extension or improvement of necessary water services and stormwater facilities, as applicable.

1. All septic tank systems and on-site sewage systems are prohibited. Existing septic systems must be abandoned or removed in accordance with Yamhill County standards.

2. All properties shall be provided with gravity service to the [city](#) wastewater system, except for [lots](#) that have unique topographic or other natural features that make gravity wastewater extension impractical as determined by the [director](#). Where gravity service is impractical, the developer shall provide all necessary pumps/lift stations and other improvements, as determined by the [director](#).

3. All developments shall be required to be linked to existing wastewater collection facilities adequately sized to serve their intended area by the construction of wastewater lines which connect to existing adequately sized wastewater facilities. All necessary [easements](#) required for the construction of these facilities shall be obtained by the developer and granted to the [city](#) pursuant to the requirements of the [city](#).

4. Specific location, size and capacity of wastewater facilities will be subject to the approval of the [director](#) with reference to the applicable wastewater master plan. All wastewater facilities shall be sized to provide adequate capacity during peak flows from the entire area potentially served by such facilities. Installation costs shall remain

entirely the developer's responsibility.

5. Temporary wastewater service facilities, including pumping stations, will be permitted only if the [director](#) approves the temporary facilities, and the developer provides for all facilities that are necessary for transition to permanent facilities.

6. The design of the wastewater facilities shall take into account provisions for the future extension beyond the development to serve upstream properties, which, in the judgment of the [city](#), cannot be feasibly served otherwise.

7. Design, construction and material standards shall be as specified by the [director](#) for the construction of such wastewater facilities in the [city](#).

RESPONSE: All proposed wastewater improvements have been designed pursuant to the requirements of the City and the above standards. Upon gaining land use approval for the proposed subdivision, the Applicant will be submitting detailed civil plans to the City's Public Works department to further demonstrate compliance with the applicable City requirements for the installation of the wastewater facilities.

F. Easements. Easements for public and private utilities shall be provided as deemed necessary by the city, special districts, and utility companies. Easements for special purpose uses shall be of a width deemed appropriate by the responsible agency. Such easements shall be recorded on easement forms approved by the city and designated on the final plat of all subdivisions and partitions. Minimum required easement width and locations are as provided in the Newberg public works design and construction standards.

RESPONSE: All easements necessary for public and private utilities will be provided as deemed necessary by the City during the review of the civil plans upon gaining land use approval for the proposed 10 Lot subdivision. All proposed and required easements will be the appropriate width and will be recorded on easement forms approved by the city and designated on the final plat.

15.505.050 Stormwater system standards.

C. General Requirement. All stormwater runoff shall be conveyed to a public storm wastewater or natural drainage channel having adequate capacity to carry the flow without overflowing or otherwise causing damage to public and/or private property. The developer shall pay all costs associated with designing and constructing the facilities necessary to meet this requirement.

RESPONSE: All stormwater runoff will be conveyed to a public storm wastewater facility in Tract A or a natural drainage channel having adequate capacity to carry the flow without overflowing or otherwise causing damage to public and/or private property.

D. Plan for Stormwater and Erosion Control. No construction of any facilities in a development included in subsection (B) of this section shall be permitted until an engineer registered in the State of Oregon prepares a stormwater report and

erosion control plan for the project. This plan shall contain at a minimum:

- 1. The methods to be used to minimize the amount of runoff, sedimentation, and pollution created from the development both during and after construction.**
- 2. Plans for the construction of stormwater facilities and any other facilities that depict line sizes, profiles, construction specifications, and other such information as is necessary for the [city](#) to review the adequacy of the stormwater plans.**
- 3. Design calculations shall be submitted for all drainage facilities. These drainage calculations shall be included in the stormwater report and shall be stamped by a licensed professional engineer in the State of Oregon. Peak design discharges shall be computed based upon the design criteria outlined in the public works design and construction standards for the [city](#).**

RESPONSE: All proposed stormwater improvements have been designed pursuant to the requirements of the City and the above standards. Upon gaining land use approval for the proposed subdivision, the Applicant will be submitting detailed civil plans to the City's Public Works department to further demonstrate compliance with the applicable City requirements for the installation of the proposed stormwater facility.

- E. Development Standards. Development subject to this section shall be planned, designed, constructed, and maintained in compliance with the Newberg public works design and construction standards.**

RESPONSE: All proposed improvements have been designed to meet the development standards of the Newberg Public Works Design and Construction Standards. Upon gaining land use approval for the proposed subdivision, the Applicant will be submitting detailed civil plans to the City's Public Works department for their review and approval to assure all public improvements are designed, constructed, and maintained in compliance with the City's public works design and construction standards.

PRELIMINARY PLAT MYRTLEWOOD SUBDIVISION

A 10 LOT SUBDIVISION
OF ADJUSTED TAX LOT 3 2 07, 3202
CITY OF NEWBERG, OREGON

LEGEND	
	EXISTING SANITARY CLEANOUT
	EXISTING SANITARY MANHOLE
	EXISTING SANITARY SEWER
	EXISTING STORM INLET
	EXISTING STORM MANHOLE
	EXISTING STORM SEWER
	EXISTING FIRE HYDRANT
	EXISTING WATER VALVE
	EXISTING WATER BLOWOFF
	EXISTING WATER METER
	EXISTING WATERLINE
	EXISTING STREET LIGHT
	EXISTING ELECTRIC BOX
	EXISTING JUNCTION BOX
	EXISTING COMMUNICATION BOX
	EXISTING STREET CENTERLINE
	EXISTING PROPERTY LINE
	EXISTING BOUNDARY OF SITE
	EXISTING LIMITS OF WETLAND
	EXISTING FENCELINE
	PROPOSED PAVEMENT SAWCUT LINE
	EXISTING 2 FOOT CONTOUR
	EXISTING 10 FOOT CONTOUR
	PROPOSED SANITARY MANHOLE
	PROPOSED SANITARY SEWER
	PROPOSED SANITARY LATERAL
	PROPOSED STORM INLET
	PROPOSED STORM MANHOLE
	PROPOSED STORM SEWER
	PROPOSED STORM LATERAL
	PROPOSED FIRE HYDRANT
	PROPOSED WATER VALVE
	PROPOSED WATER METER
	PROPOSED WATERLINE
	PROPOSED STREET LIGHT
	PROPOSED STREET TREE
	PROPOSED RIP-RAP
	PROPOSED STREET CENTERLINE
	PROPOSED LOT LINE
	PROPOSED EASEMENT LINE
	PROPOSED FLOWLINE OF SWALE
	PROPOSED 2 FOOT CONTOUR
	PROPOSED 10 FOOT CONTOUR

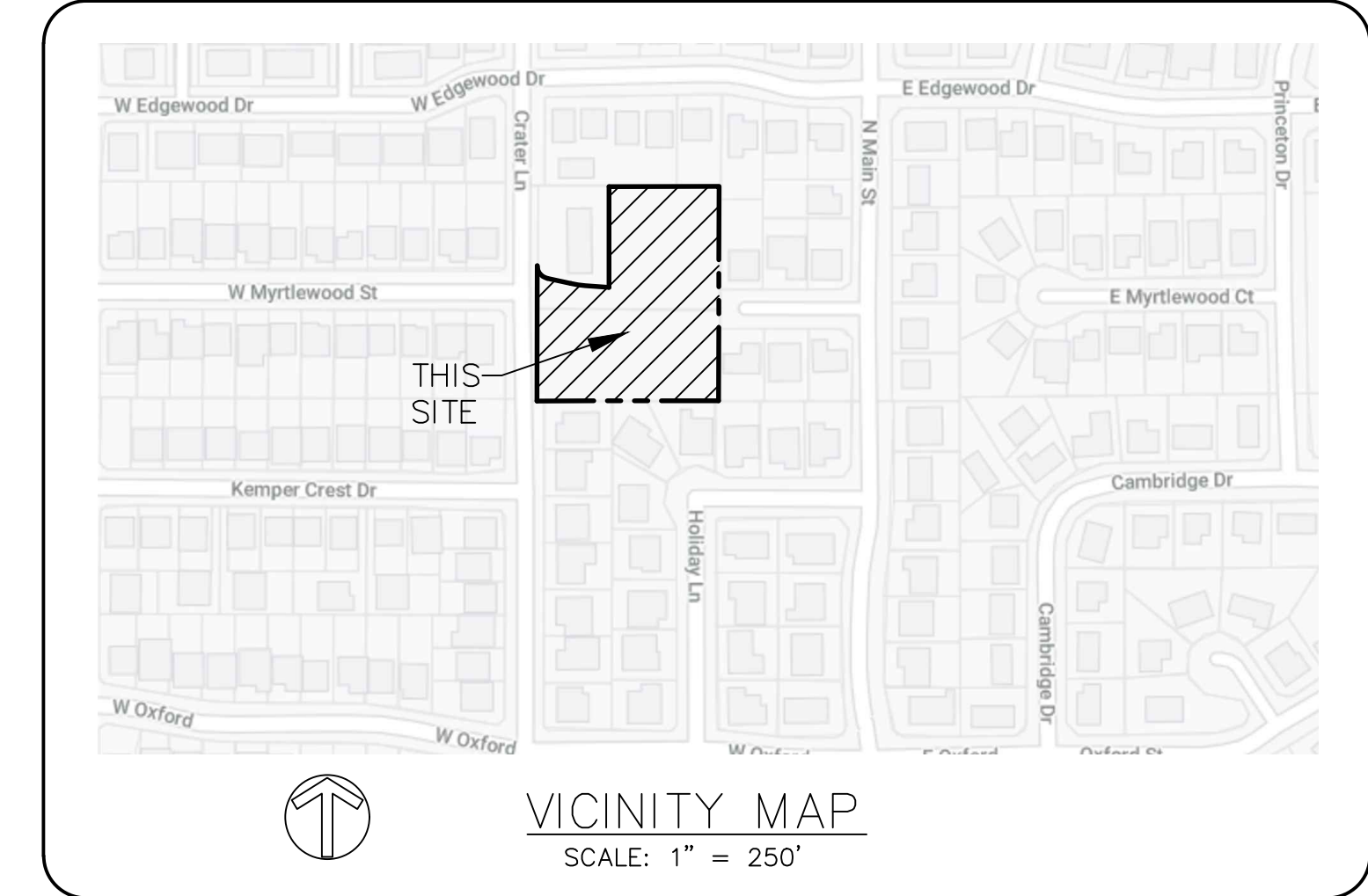
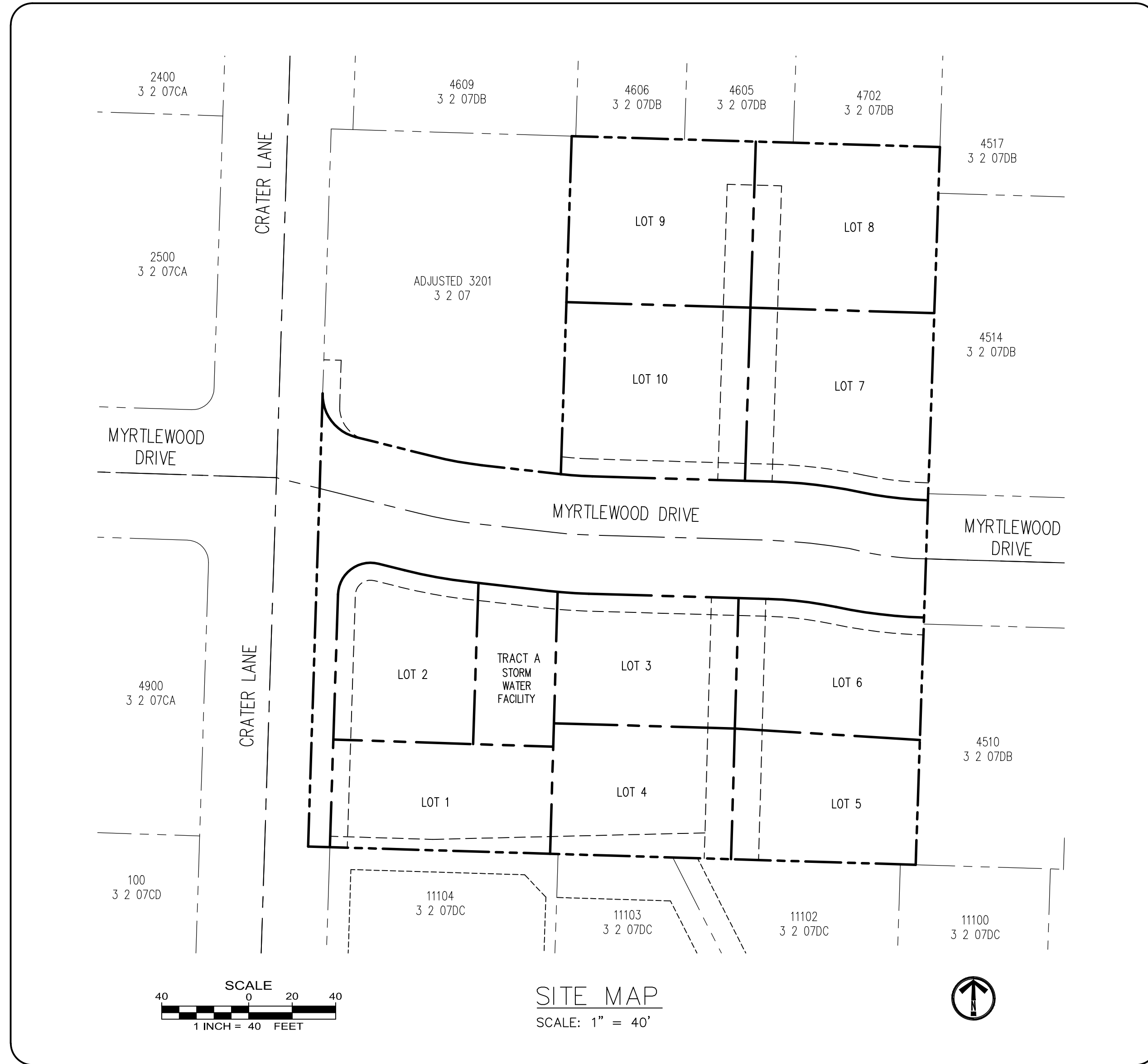

SITE INFORMATION	
SITE AREA:	76,006 SF (1.74 AC)
ZONING:	R1
TAX MAP:	3 4 07
TAX LOT:	ADJUSTED 3202
NUMBER OF LOTS:	10

VERTICAL DATUM
VERTICAL DATUM IS BASED ON THE NATIONAL VERTICAL DATUM OF 1929 (NGVD 29).

PROJECT CONTACTS			
DEVELOPER:	GREENWING COMPANIES 16869 SW 65TH AVENUE, SUITE 115 LAKE OSWEGO, OREGON 97035 CONTACT: NICK DANIKEN 503-473-8870 NICK@GREENWINGPDX.COM	PLANNER:	EMERIO DESIGN 6445 SW FALLBROOK PL., SUITE 100 BEAVERTON, OREGON 97008 CONTACT: STEVE MILLER 541-318-7487 STEVE@EMERIODSIGN.COM
OWNER:	GREENWING COMPANIES 16869 SW 65TH AVENUE, SUITE 115 LAKE OSWEGO, OREGON 97035 CONTACT: NICK DANIKEN	ENGINEER:	EMERIO DESIGN 6445 SW FALLBROOK PL., SUITE 100 BEAVERTON, OREGON 97008 CONTACT: ERIC EVANS 503-853-1910 ERIC@EMERIODSIGN.COM
		SURVEYOR:	EMERIO DESIGN 6445 SW FALLBROOK PL., SUITE 100 BEAVERTON, OREGON 97008 CONTACT: DWAYNE KUFCHAK 971-724-2125 DWAYNE@EMERIODSIGN.COM

DRAWING INDEX	
1	COVER SHEET
2	EXISTING CONDITIONS & PRELIMINARY DEMOLITION PLAN
3	PRELIMINARY PLAT
4	PRELIMINARY SITE & UTILITY PLAN
5	PRELIMINARY PROFILES & TYPICAL STREET SECTIONS
6	PRELIMINARY GRADING PLAN
7	AERIAL & CIRCULATION PLAN

MYRTLEWOOD SUBDIVISION
A 10 LOT SUBDIVISION OF
ADJUSTED TAX LOT 3202
TAX MAP 3 2 07
CITY OF NEWBERG, OREGON

PRELIMINARY PLAT
COVER SHEET

NO.	DATE	REVISIONS DESCRIPTION

EMERIO
ENGINEERING • SURVEYING • DESIGN
6445 SW FALLBROOK PLACE, SUITE 100
BEAVERTON, OREGON 97008
TEL: (503) 746-9612
FAX: (503) 639-9692
www.emeriodesign.com

TENTATIVE PLAT
SCALE: 1" = 40'

SHEET
1 OF 7

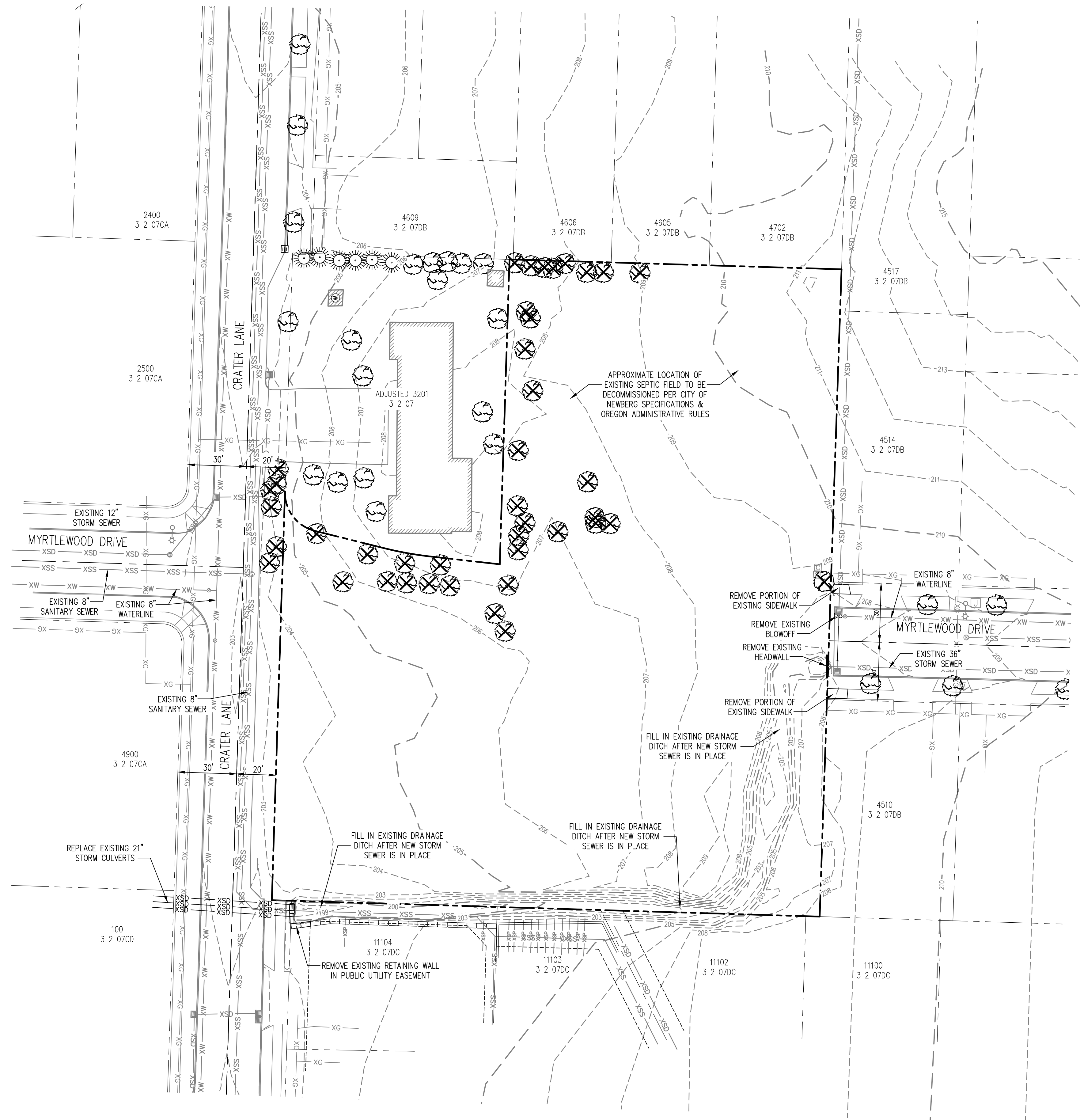
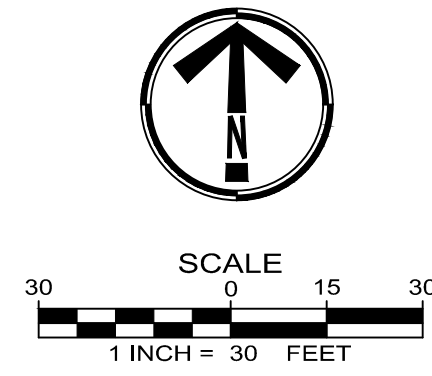

EXISTING CONDITIONS &
PRELIMINARY DEMOLITION PLAN
SCALE: 1" = 30'

MYRTLEWOOD SUBDIVISION
A 10 LOT SUBDIVISION OF
ADJUSTED TAX LOT 3202
TAX MAP 3 2 07
CITY OF NEWBERG, OREGON

PRELIMINARY PLAT
EXISTING CONDITIONS &
PRELIMINARY
DEMOLITION PLAN

NO.	DATE	REVISIONS	DESCRIPTION

EMERIO
ENGINEERING • SURVEYING • DESIGN
6445 SW FALLBROOK PLACE, SUITE 100
BEAVERTON, OREGON 97008
TEL: (503) 746-9812
FAX: (503) 639-9892
www.emeriodesign.com

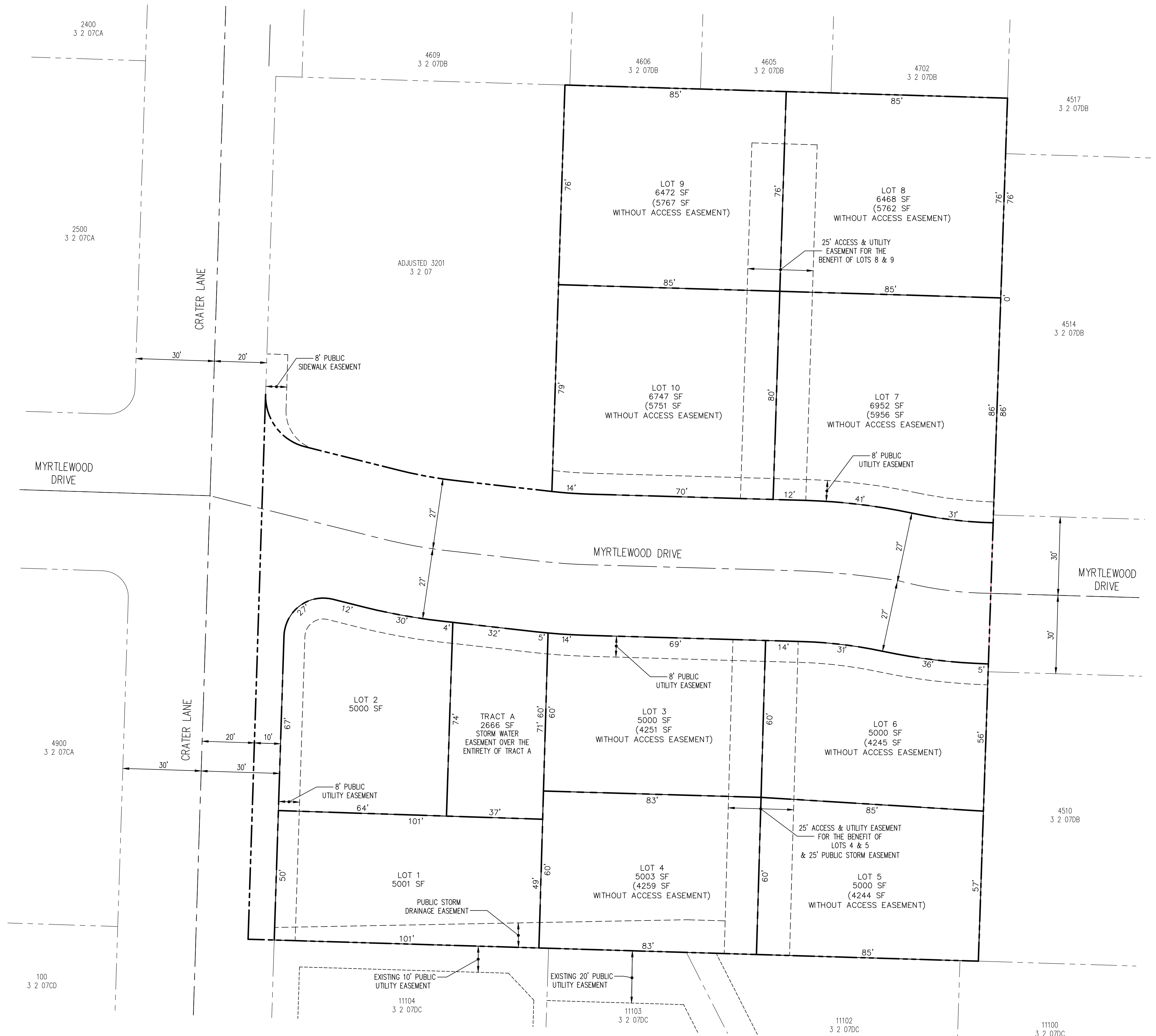
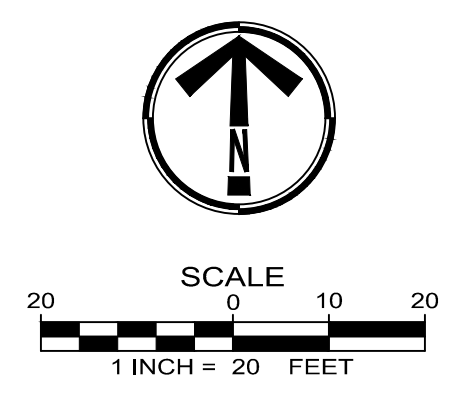

PRELIMINARY PLAT
SCALE: 1" = 20'

MYRTLEWOOD SUBDIVISION
A 10 LOT SUBDIVISION OF
ADJUSTED TAX LOT 3202
TAX MAP 3 2 07
CITY OF NEWBERG, OREGON

PRELIMINARY PLAT
PRELIMINARY PLAT

NO.	DATE	DESCRIPTION

EMERIO
ENGINEERING • SURVEYING • DESIGN
6445 SW FALLBROOK PLACE, SUITE 100
BEAVERTON, OREGON 97008
TEL: (503) 746-9812
FAX: (503) 639-9892
www.emeriodesign.com

SHEET
3
OF
7

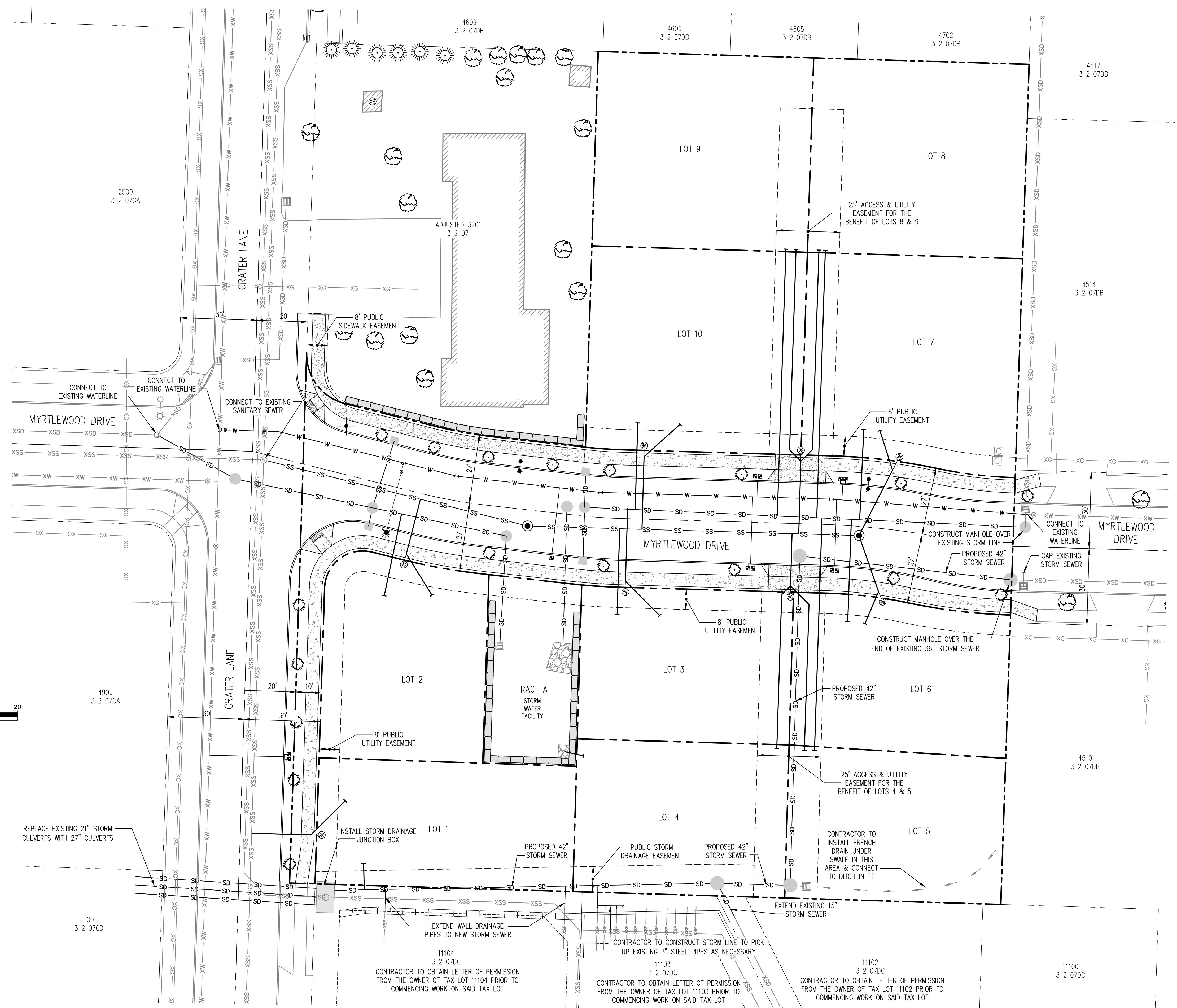

PRELIMINARY SITE PLAT
SCALE: 1" = 20'

MYRTLEWOOD SUBDIVISION
A 10 LOT SUBDIVISION OF
ADJUSTED TAX LOT 3202
TAX MAP 3 2 07
CITY OF NEWBERG, OREGON

PRELIMINARY PLAT
PRELIMINARY SITE PLAN

NO.	DATE	DESCRIPTION

EMERIO
ENGINEERING • SURVEYING • DESIGN
6445 SW FALLBROOK PLACE, SUITE 100
BEAVERTON, OREGON 97008
TEL: (503) 746-9812
FAX: (503) 639-9892
www.emeriodesign.com

SHEET
4
OF
7

Plotted: Aug 31, 2021 - 9:25am, N:\0780-003 SW Myrtlewood Street Subdivision (Crater Lane Phase 2)\vaw\plan\0780-003 (04) Site.dwg, Layout: (04) Site

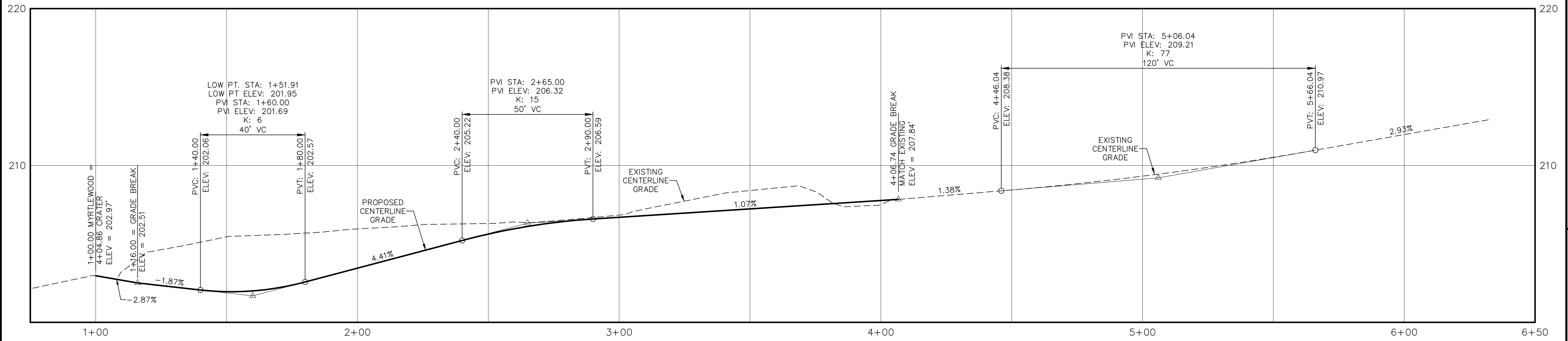

MYRTLEWOOD STREET PRELIMINARY PROFILE

HORIZONTAL SCALE: 1" = 20'
VERTICAL SCALE: 1" = 5'

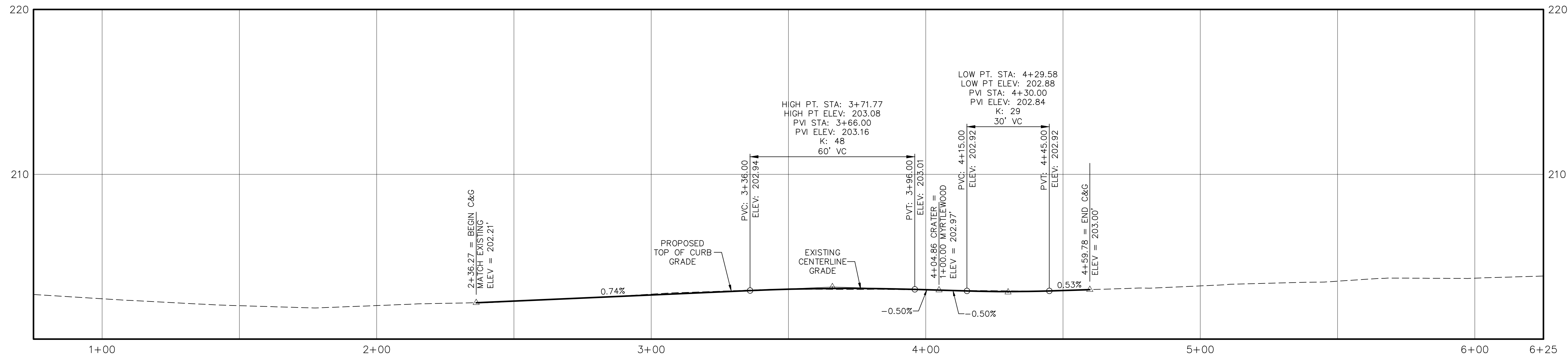

CRATER DRIVE PRELIMINARY PROFILE

HORIZONTAL SCALE: 1" = 20'
VERTICAL SCALE: 1" = 5'

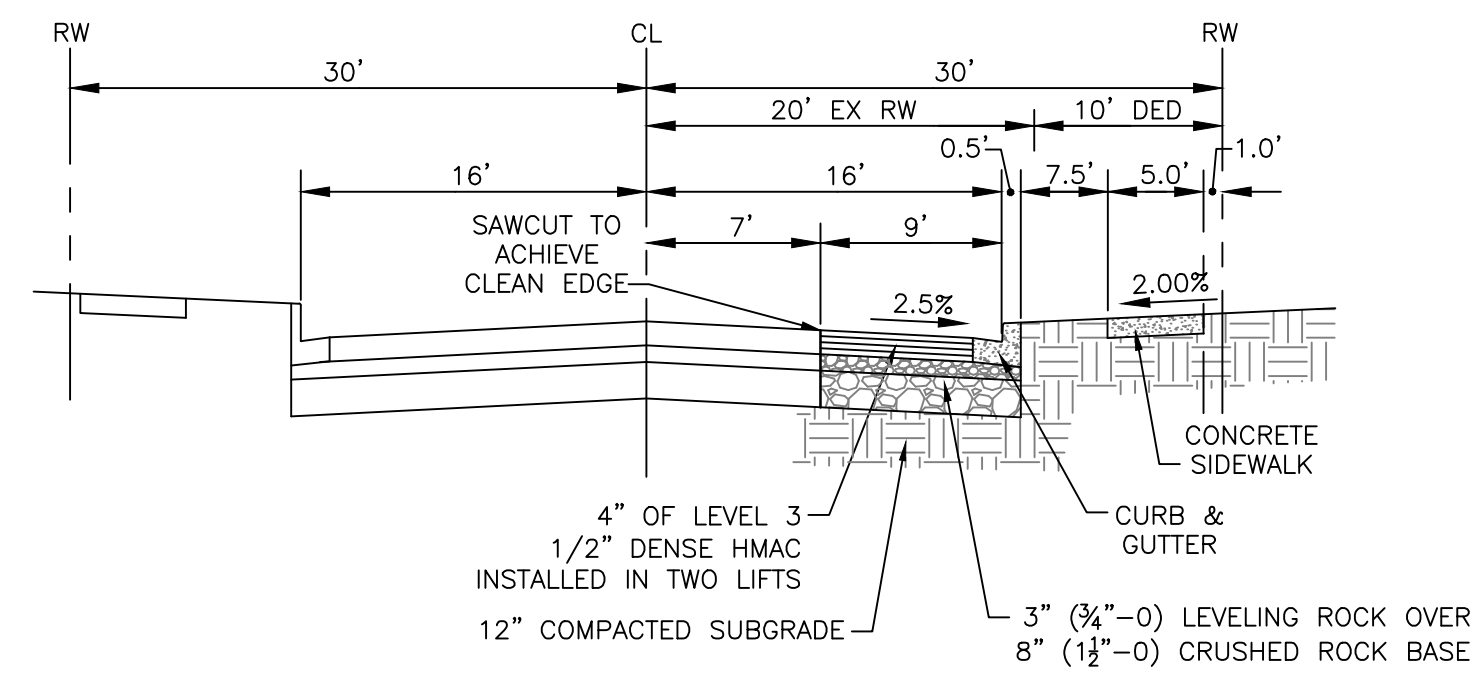

CRATER DRIVE TYPICAL SECTION
NOT TO SCALE

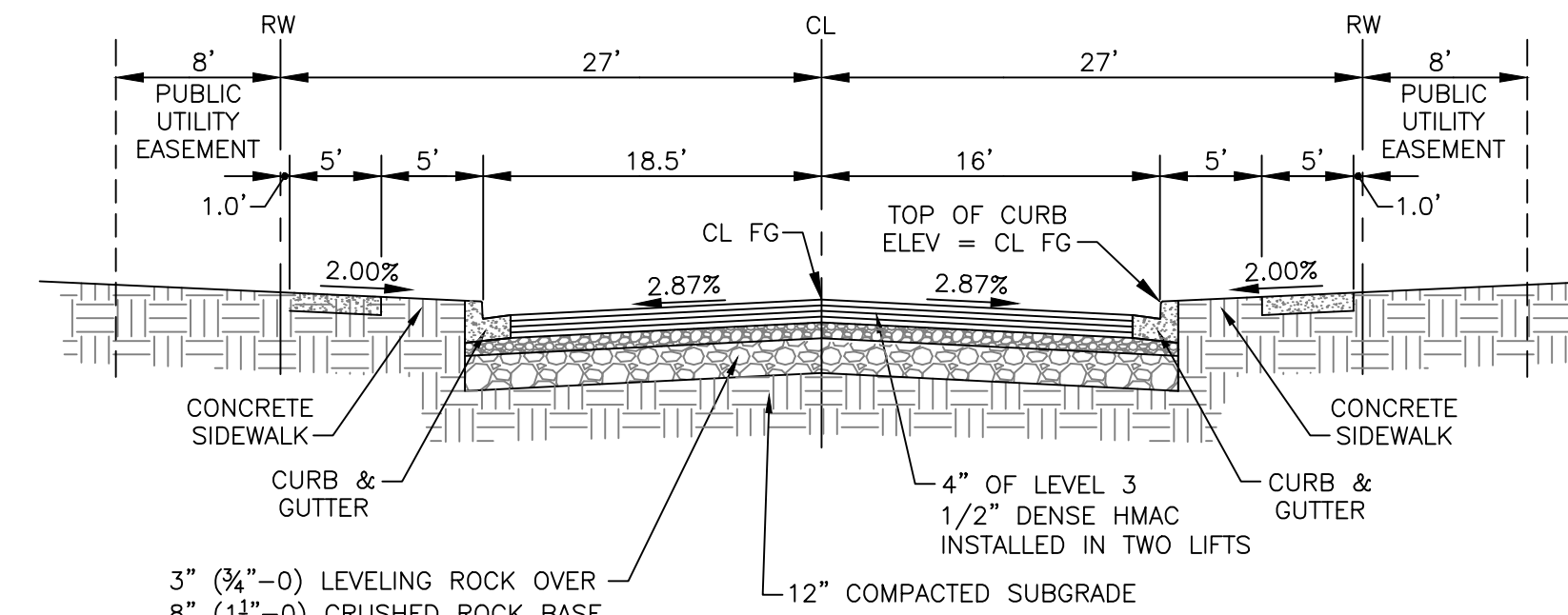

MYRTLEWOOD STREET TYPICAL SECTION
NOT TO SCALE

MYRTLEWOOD SUBDIVISION
A 10 LOT SUBDIVISION OF
ADJUSTED TAX LOT 3202
TAX MAP 3 2 07
CITY OF NEWBERG, OREGON

PRELIMINARY PLAT
PRELIMINARY PROFILES &
TYPICAL STREET SECTIONS

NO.	DATE	DESCRIPTION

EMERIO
ENGINEERING • SURVEYING • DESIGN
6445 SW FALLBROOK PLACE, SUITE 100
BEAVERTON, OREGON 97008
TEL: (503) 746-9612
FAX: (503) 639-9892
www.emeriodesign.com

SHEET
5
OF
7

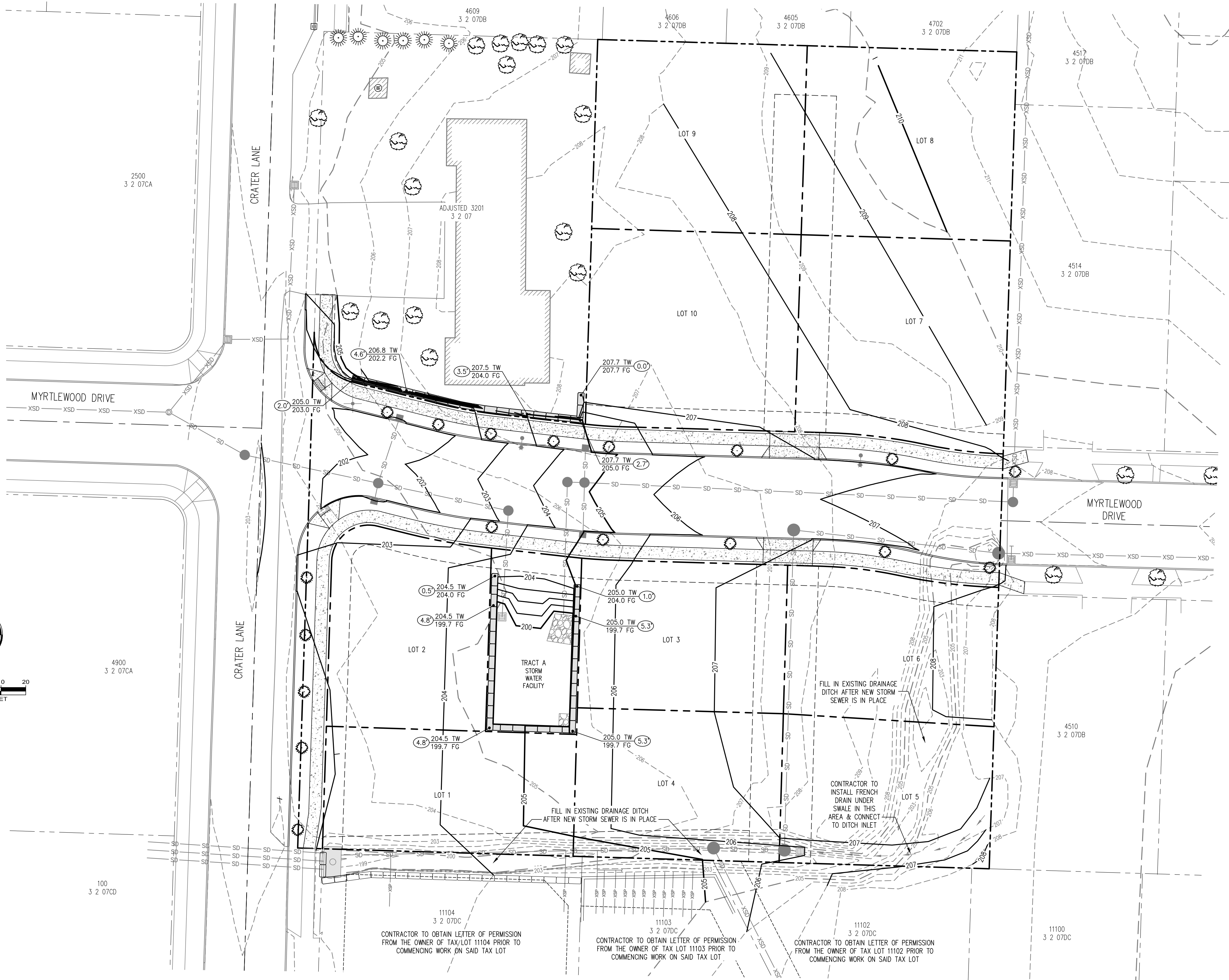
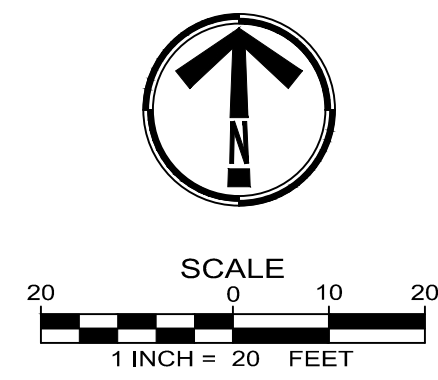

PRELIMINARY GRADING PLAN
SCALE: 1" = 20'

CONTRACTOR TO OBTAIN LETTER OF PERMISSION FROM THE OWNER OF TAX/LOT 11104 PRIOR TO COMMENCING WORK ON SAID TAX LOT

CONTRACTOR TO OBTAIN LETTER OF PERMISSION FROM THE OWNER OF TAX LOT 11103 PRIOR TO COMMENCING WORK ON SAID TAX LOT

CONTRACTOR TO OBTAIN LETTER OF PERMISSION FROM THE OWNER OF TAX LOT 11102 PRIOR TO COMMENCING WORK ON SAID TAX LOT

MYRTLEWOOD SUBDIVISION
A 10 LOT SUBDIVISION OF
ADJUSTED TAX LOT 3202
TAX MAP 3 2 07
CITY OF NEWBERG, OREGON

PRELIMINARY PLAT
PRELIMINARY
GRADING PLAN

NO.	DATE	REVISIONS DESCRIPTION

EMERIO
ENGINEERING • SURVEYING • DESIGN
6445 SW FALLBROOK PLACE, SUITE 100
BEAVERTON, OREGON 97008
TEL: (503) 746-9812
FAX: (503) 639-9892
www.emeriodesign.com

Plotted: Aug 31, 2021 - 9:26am, N:\0780-003 SW Myrtlewood Street Subdivision (Crater Lane Phase 2)\wpa\plan\0780-003 (06) Grading.dwg, Layout: (06) Grad EMERIO PROJECT NO. 0780-003



AERIAL & CIRCULATION PLAN
SCALE: 1" = 40'

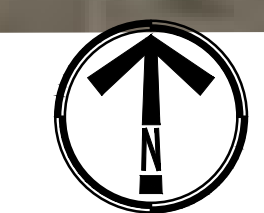

SHEET
7
OF
7

EMERIO
ENGINEERING • SURVEYING • DESIGN
6445 SW FALLBROOK PLACE, SUITE 100
BEAVERTON, OREGON 97008
TEL: (503) 746-9812
FAX: (503) 639-9892
www.emeriodesign.com

NO.	DATE	REVISIONS DESCRIPTION

PRELIMINARY PLAT
AERIAL & CIRCULATION
PLAN

MYRTLEWOOD SUBDIVISION
A 10 LOT SUBDIVISION OF
ADJUSTED TAX LOT 3202
TAX MAP 3 2 07
CITY OF NEWBERG, OREGON



Preliminary Stormwater Report for
Myrtlewood Subdivision at
Tax Lot 3201 & 3202
Tax Map T3S R2W 7DB
Newberg, Oregon

Emerio Project Number: 0780-003
City of Newberg Application No.: TBD
Date: 08/24/2021

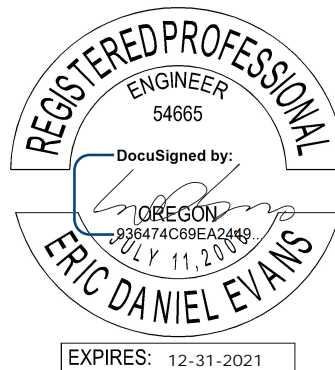

Prepared For:
Fredrick L Sparks
Linda J Hamlett Living Trust
905 Hoback Avenue
Erwin, Tennessee 37650

Prepared By:
Eric Evans, PE
Emerio Design, LLC
6445 SW Fallbrook Pl., Suite 100
Beaverton, Oregon 97008
(503) 853-1910
eric@emeriodesign.com

Table of Contents:

APPENDIX A

- (1) Vicinity Map

APPENDIX B

- (1) Soil Classification Map--"Soils Survey for Yamhill County"
- (2) Curve Number Table

APPENDIX C

- (1) Basin Area Tabulated Data
- (2) Detention and Water Quality HydroCAD Plots
- (3) Bypass Conveyance Spreadsheet
- (4) Conveyance HydroCAD Plots

APPENDIX D

- (1) Pre-Developed Basin Map
- (2) Post-Developed Basin Map
- (3) Upstream Basin Map

Project Overview and Description:

The proposed project will convert an existing 1.74-acre parcel into a 10-lot subdivision. Currently, the site is mostly grassed and is zoned R-1. The existing lot lines between tax lots 3201 and 3202 will be adjusted as part of the development. The proposed development will occur on the adjusted tax lot 3202, while tax lot 3201 will retain its existing structures and paved areas. In addition to the 10 new homes, the development will include an extension of Myrtlewood Drive with associated walkways, and frontage improvements along Crater Lane. See Appendix A(1) for a vicinity map of the site.

Soil Classification:

The NRCS soil survey of Yamhill County, Oregon classifies the onsite soils as Woodburn silt loam and Wapato silt loam. The associated hydrologic soil groups of these soils are C and C/D, respectively. Hydraulic soil group (HSG) C was used to design the onsite proposed storm facilities. Curve numbers of 74 and 86 were used for pre and post-developed pervious surfaces. A curve number of 98 was set for impervious surfaces, reference appendices B(1) and B(2).

Basin Delineation:

The onsite and offsite basins were delineated after determining how stormwater runoff is collected in both pre and post-developed conditions. Residential lot impervious areas were set at 2,877 SF per lot per Newberg Public Works Design and Construction Standards section 4.6.1.II. All offsite right-of-way areas without measurable impervious areas available were assumed to be 85% impervious. See Appendix C(1) for a tabulated basin areas and Appendix D for all basin maps.

Water Quality:

Water quality requirements will be met by means of infiltrating runoff through the growing media of the proposed detention pond located within Tract A. The proposed development will create 44,675 SF of new impervious area that requires water quality treatment. Due to grading restrictions, 14,515 SF of new impervious area from the western portion of the site and Crater Lane will be unable to route runoff to the proposed pond location. To compensate, some upstream areas that route runoff through the existing segment of Myrtlewood Drive to the east of the site will be redirected to the pond to proxy treat existing impervious areas for the new untreated impervious areas. Of the 40,551 SF of existing impervious area that will route through the pond, exactly 14,515 SF will be treated to meet stormwater requirements.

Treatment will be achieved by raising the pond outlet structure above the peak water surface elevation caused by runoff from 44,675 SF of impervious area during the water quality storm event. This will force the impervious runoff during the water quality storm to infiltrate. See Appendix C(2) for HydroCAD plots of the water quality storm.

Quantity Control/Detention:

Detention will be provided for the half of the 2, 2, 10, and 25-year 24-hour design storms. Flows are detained via the detention pond located within onsite Tract A. All developed flows and upstream flows routed to the pond are considered in detention calculations. As some developed flows will go undetained, onsite and upstream areas that route to the pond will be overdetained to match pre-developed and post-developed peak flows for the whole development. Flow is controlled for the half of the 2, 2, 10, and 25-year flows via two orifices with information shown below:

- Orifice #1: 3.3" diameter, elevation 198.00'
- Orifice #2: 5.7" diameter, elevation 201.85'

Both orifices are set in an outflow control structure per City of Newberg standard drawings 417 and 418.

Storm Event	Pre-Developed and Detained Post-Developed Flows	
	Pre-Dev.	Post-Dev. w/ Detention
1/2 of 2 Year	0.53	0.40
2-Year	1.07	0.81
10-Year	1.88	1.45
25-Year	2.32	1.82

As shown in the tables above, the detention requirement is met by limiting the peak discharge of each of the return periods from the pre to post-developed conditions. With the 25-year design water elevation at 202.98' and the top of pond at 204.00', greater than one foot of freeboard is maintained. See Appendix C(2) for pre and post-developed HydroCAD detention plots.

Stormwater Conveyance:

Currently, upstream flows from the northeast and southeast route through the site via an existing ditch that runs along the east and south borders of the site. As part of the development, 42" onsite pipe segments will replace the ditch as the onsite bypass system for upstream flows. Lot 1 will also route to these new pipes via a proposed lateral. In the original ditch flow path, three parallel 21" culverts convey all upstream flows from the onsite ditch to the west side of Crater Lane at the southwest corner of the site. As part of the development, these culverts will be replaced by 27" to mitigate existing flooding issues at that point in the existing storm system. A capacity analysis of this proposed system was performed, which showed that all proposed bypass pipe segments are within capacity assuming gravity flow. The three parallel culverts are assumed to have identical geometries and will each manage a third of the tributary flows. See Appendix C(3) for the capacity spreadsheet, Appendix C(4) for HydroCAD plots of the tributary flows, and Appendix D(3) for a map of the tributary upstream areas.

Onsite and upstream flows that are managed by the onsite pond will be routed to and from the pond using proposed storm mains. Runoff collection will be achieved

via onsite or existing catch basins and storm laterals. After treatment and detention, these flows will route to the existing public storm sewer via a connection with an existing manhole at the intersection of Crater Lane and Myrtlewood Drive. Most developed flows that go untreated will route to the same existing manhole and will also be collected via storm laterals and onsite catch basins. The rest of the of the Crater Lane frontage runoff will flow overland southward to existing catch basins.

Conclusion:

The design of the proposed site satisfies the water quality and water quantity standards set by the 2015 Newberg Public Works Design and Construction Standards.

Appendix A:

Appendix A(1)
Vicinity Map

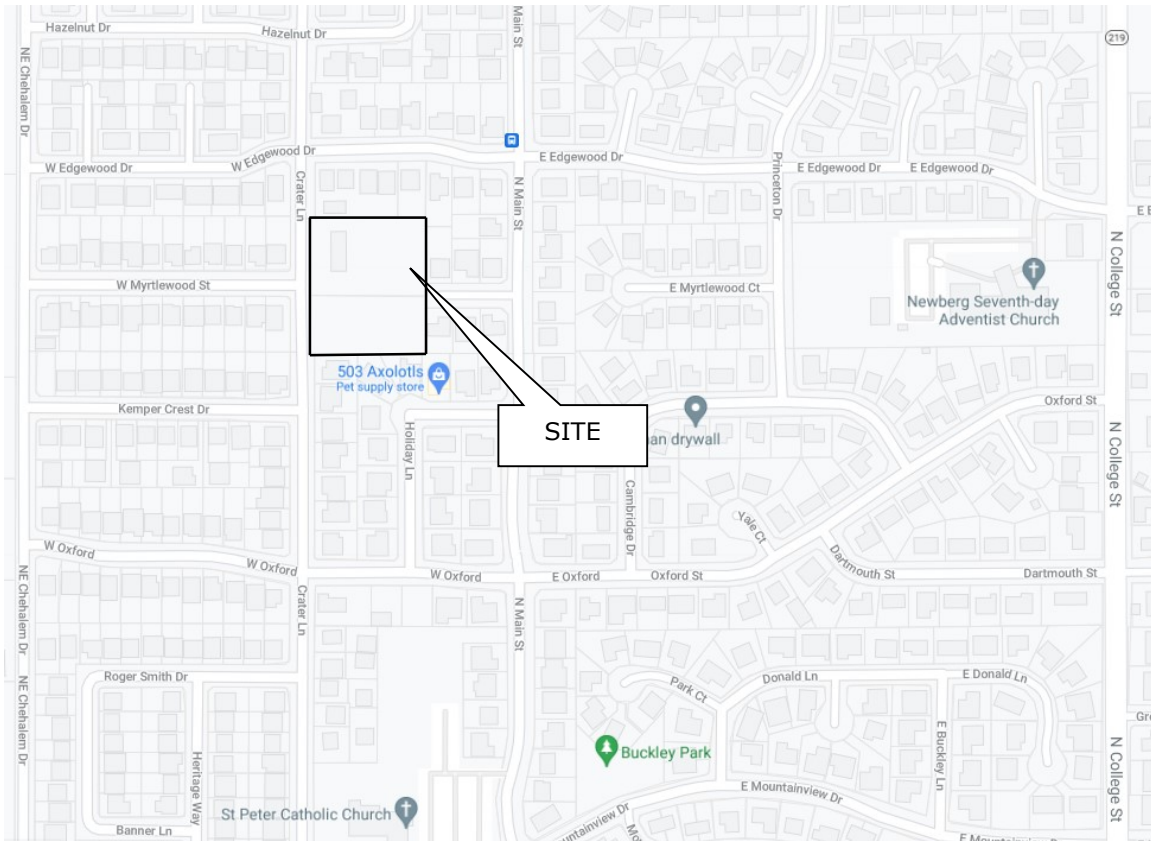

Appendix B:

Appendix B(1)
Soil Classification Map



Tables — Hydrologic Soil Group — Summary By Map Unit

Summary by Map Unit — Yamhill County, Oregon (OR071)

Map unit symbol	Map unit name	Rating	Acres in AOI	Percent of AOI
2013A	Wapato silty clay loam, 0 to 3 percent slopes	C/D	0.8	35.8%
2310A	Woodburn silt loam, 0 to 3 percent slopes	C	1.5	64.2%
Totals for Area of Interest			2.3	100.0%

Appendix B(2)
Curve Number Table

RUNOFF CURVE NUMBERS (TR55)					
Table 2-2a: Runoff curve numbers for urban areas ¹					
Cover description		CN for hydrologic soil group			
Cover type and hydrologic condition	Average percent impervious area ²	A	B	C	D
<i>Fully developed urban areas (vegetation established)</i>					
Open space (lawns, parks, golf courses, cemeteries, etc.) ³ :					
Poor condition (grass cover <50%)				86	89
Fair condition (grass cover 50% to 75%)		49	69	79	84
Good condition (grass cover >75%)				74	80
Impervious areas:					
Paved parking lots, roofs, driveways, etc. (excluding right-of-way)		98	98	98	98
Streets and roads:					
Paved; curbs and storm sewers (excluding right-of-way)				98	98
Paved; open ditches (including right-of-way)					
Gravel (including right-of-way)		83	89	92	93
Dirt (including right-of-way)		76	85	89	91
		72	82	87	89
Western desert urban areas:					
Natural desert landscaping (pervious areas only) ⁴		63	77	85	88
Artificial desert landscaping (impervious weed barrier, desert shrub with 1- to 2-inch sand or gravel mulch and basin borders)		96	96	96	96
Urban districts:					
Commercial and business	85	89	92	94	95
Industrial	72	81	88	91	93
Residential districts by average lot size:					
1/8 acre or less (town houses)	65	77	85	90	92
1/4 acre	38	61	75	83	87
1/3 acre	30	57	72	81	86
1/2 acre	25	54	70	80	85
1 acre	20	51	68	79	84
2 acres	12	46	65	77	82

Use CN = 86 for Post-Developed Pervious Areas

Use CN = 74 for Onsite Pre-Developed Pervious Areas

Use CN = 98 for Impervious Areas

Appendix C:

Basin Area Tabulated Data
 Myrtlewood Street Subdivision

Appendix C(1)

Basin #	Name	Total Area SF	Total Area Acres	Number of Lots	Lot Impervious SF	ROW/Tract Imp SF	Total Impervious SF	Total Pervious (Calc'd) SF
100	Pre-developed Onsite Detained	57,865	1.33	1	0	0	0	57,865
101	Pre-Developed Undetained	21,295	0.49	1	0	270	270	21,025
200	Post-developed Onsite Detained	57,865	1.33	8	23,016	7,144	30,160	27,705
201	Undetained Development	21,295	0.49	2	5,754	8,761	14,515	6,780
301	Upstream 1 (Proxy Treated Area)	94,082	2.16	9	25,893	14,658	40,551	53,531
302	Upstream 2	429,419	9.86	39	112,203	111,395	223,598	205,821
303	Upstream 3	5,457,351	125.28	314	1,079,378	958,307	2,037,685	3,419,666

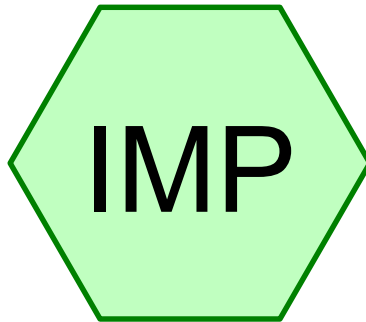

Treated Impervious
Area

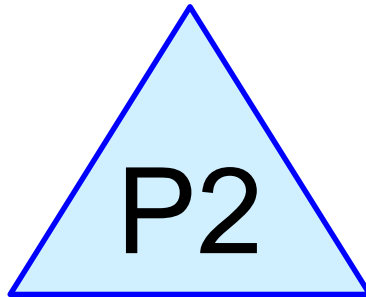

Onsite Pond

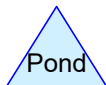
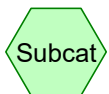

0780-003 HydroCAD Detention & WQ

Prepared by Emerio Design LLC

HydroCAD® 10.00-24 s/n 04804 © 2018 HydroCAD Software Solutions LLC

Printed 5/25/2021

Page 2

Area Listing (selected nodes)

Area (sq-ft)	CN	Description (subcatchment-numbers)
44,675	98	Impervious (IMP)
44,675	98	TOTAL AREA

0780-003 HydroCAD Detention & WQ

Type IA 24-hr WQ Rainfall=1.00"

Prepared by Emerio Design LLC

Printed 5/25/2021

HydroCAD® 10.00-24 s/n 04804 © 2018 HydroCAD Software Solutions LLC

Page 3

Summary for Subcatchment IMP: Treated Impervious Area

Runoff = 0.21 cfs @ 7.90 hrs, Volume= 2,944 cf, Depth= 0.79"

Runoff by SBUH method, Split Pervious/Imperv., Time Span= 0.00-50.00 hrs, dt= 0.01 hrs
Type IA 24-hr WQ Rainfall=1.00"

Area (sf)	CN	Description
* 44,675	98	Impervious
44,675	98	100.00% Impervious Area

Tc (min)	Length (feet)	Slope (ft/ft)	Velocity (ft/sec)	Capacity (cfs)	Description
5.0					Direct Entry,

Subcatchment IMP: Treated Impervious Area

Hydrograph

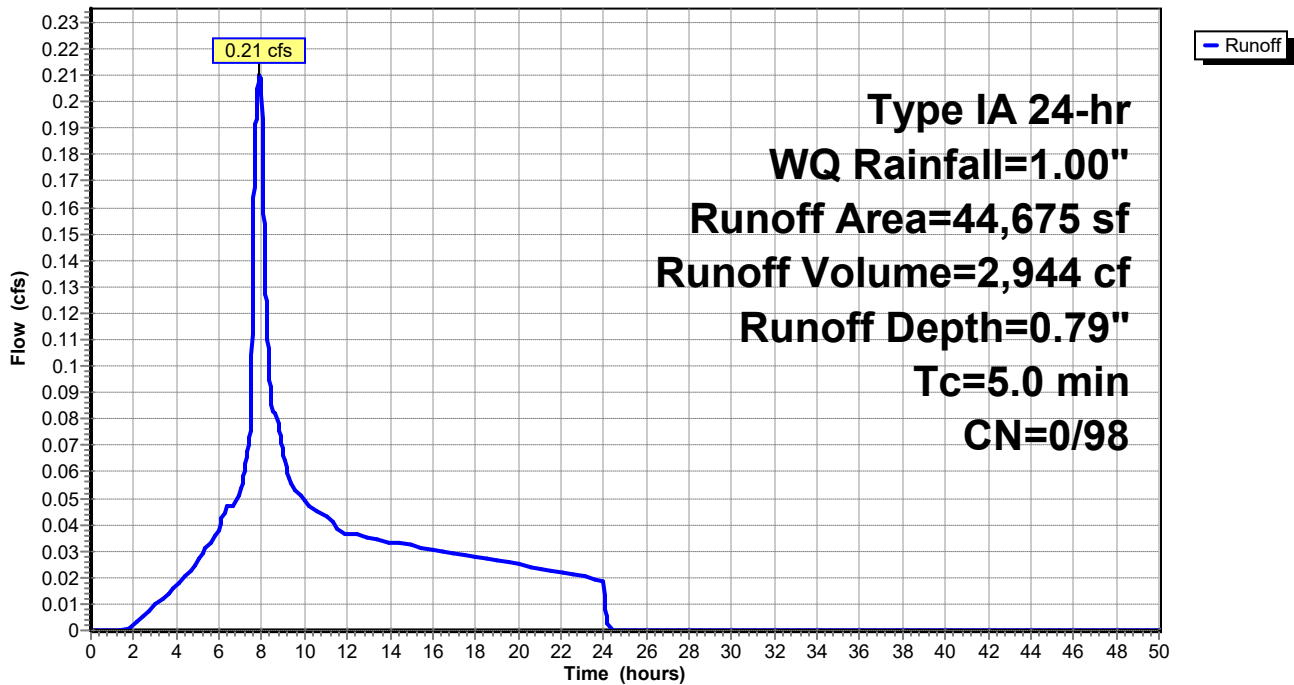

0780-003 HydroCAD Detention & WQ

Type IA 24-hr WQ Rainfall=1.00"

Prepared by Emerio Design LLC

Printed 5/25/2021

HydroCAD® 10.00-24 s/n 04804 © 2018 HydroCAD Software Solutions LLC

Page 4

Summary for Pond P2: Onsite Pond

Inflow Area = 44,675 sf, 100.00% Impervious, Inflow Depth = 0.79" for WQ event
 Inflow = 0.21 cfs @ 7.90 hrs, Volume= 2,944 cf
 Outflow = 0.06 cfs @ 9.14 hrs, Volume= 2,944 cf, Atten= 70%, Lag= 74.6 min
 Primary = 0.06 cfs @ 9.14 hrs, Volume= 2,944 cf

Routing by Stor-Ind method, Time Span= 0.00-50.00 hrs, dt= 0.01 hrs
 Peak Elev= 200.01' @ 9.14 hrs Surf.Area= 1,341 sf Storage= 416 cf

Plug-Flow detention time= 45.5 min calculated for 2,944 cf (100% of inflow)
 Center-of-Mass det. time= 45.5 min (758.1 - 712.6)

Volume	Invert	Avail.Storage	Storage Description
#1	199.70'	6,697 cf	Custom Stage Data (Prismatic) Listed below (Recalc)
Elevation (feet)	Surf.Area (sq-ft)	Inc.Store (cubic-feet)	Cum.Store (cubic-feet)
199.70	1,301	0	0
200.00	1,339	396	396
201.00	1,462	1,401	1,797
202.00	1,577	1,520	3,316
203.00	1,686	1,632	4,948
203.50	1,750	859	5,807
204.00	1,813	891	6,697

Device	Routing	Invert	Outlet Devices
#1	Primary	197.70'	12.0" Round Outlet Pipe L= 40.0' CMP, square edge headwall, Ke= 0.500 Inlet / Outlet Invert= 197.70' / 197.50' S= 0.0050 '/' Cc= 0.900 n= 0.013, Flow Area= 0.79 sf
#2	Device 1	198.00'	3.3" Vert. Low Orifice C= 0.620
#3	Device 2	200.05'	24.0" x 24.0" Horiz. Low Grate Inlet C= 0.620 Limited to weir flow at low heads
#4	Device 1	201.85'	5.7" Vert. High Orifice C= 0.620
#5	Device 1	199.70'	2.000 in/hr Growing Media Infiltration over Surface area above 197.70' Excluded Surface area = 0 sf

Primary OutFlow Max=0.06 cfs @ 9.14 hrs HW=200.01' (Free Discharge)

- 1=Outlet Pipe (Passes 0.06 cfs of 4.67 cfs potential flow)
- 2=Low Orifice (Passes 0.00 cfs of 0.40 cfs potential flow)
- 3=Low Grate Inlet (Controls 0.00 cfs)
- 4=High Orifice (Controls 0.00 cfs)
- 5=Growing Media Infiltration (Exfiltration Controls 0.06 cfs)

Pond P2: Onsite Pond

Hydrograph

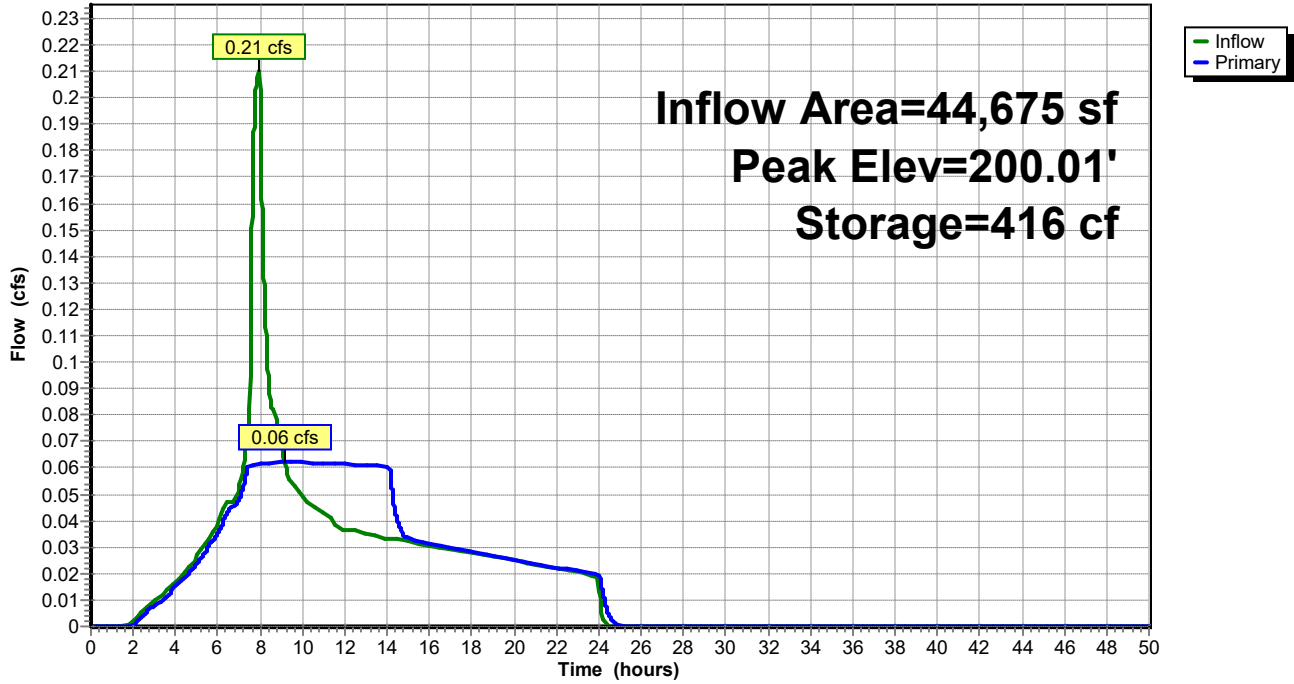

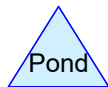
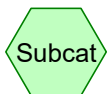
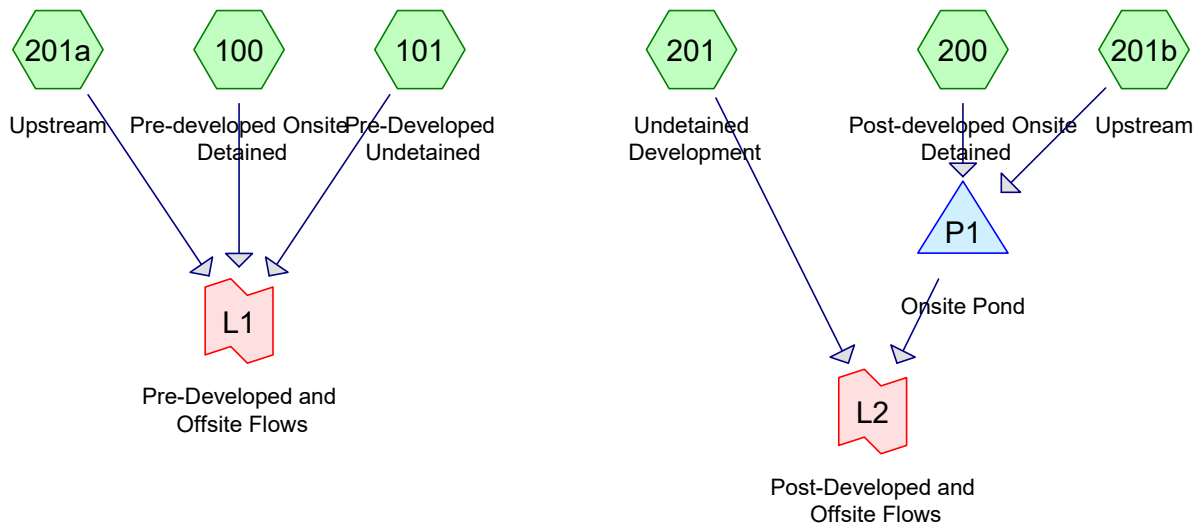

0780-003 HydroCAD Detention & WQ

Prepared by Emerio Design LLC

HydroCAD® 10.00-24 s/n 04804 © 2018 HydroCAD Software Solutions LLC

Printed 5/25/2021

Page 2

Area Listing (selected nodes)

Area (sq-ft)	CN	Description (subcatchment-numbers)
126,048	98	Impervious (101, 200, 201, 201a, 201b)
78,891	74	Pervious (100, 101)
154,277	86	Pervious (200, 201, 201a, 201b)
359,216	88	TOTAL AREA

0780-003 HydroCAD Detention & WQ

Prepared by Emerio Design LLC

HydroCAD® 10.00-24 s/n 04804 © 2018 HydroCAD Software Solutions LLC

Type IA 24-hr 2-YR Rainfall=2.50"

Printed 5/25/2021

Page 3

Summary for Subcatchment 100: Pre-developed Onsite Detained

Runoff = 0.10 cfs @ 8.01 hrs, Volume= 2,939 cf, Depth= 0.61"

Runoff by SBUH method, Split Pervious/Imperv., Time Span= 0.00-50.00 hrs, dt= 0.01 hrs
Type IA 24-hr 2-YR Rainfall=2.50"

Area (sf)	CN	Description
* 57,979	74	Pervious
57,979	74	100.00% Pervious Area

Tc (min)	Length (feet)	Slope (ft/ft)	Velocity (ft/sec)	Capacity (cfs)	Description
6.8	50	0.0170	0.12		Sheet Flow, Grass: Short n= 0.150 P2= 2.50"
2.6	154	0.0195	0.98		Shallow Concentrated Flow, Short Grass Pasture Kv= 7.0 fps
9.4	204	Total			

Subcatchment 100: Pre-developed Onsite Detained

Hydrograph

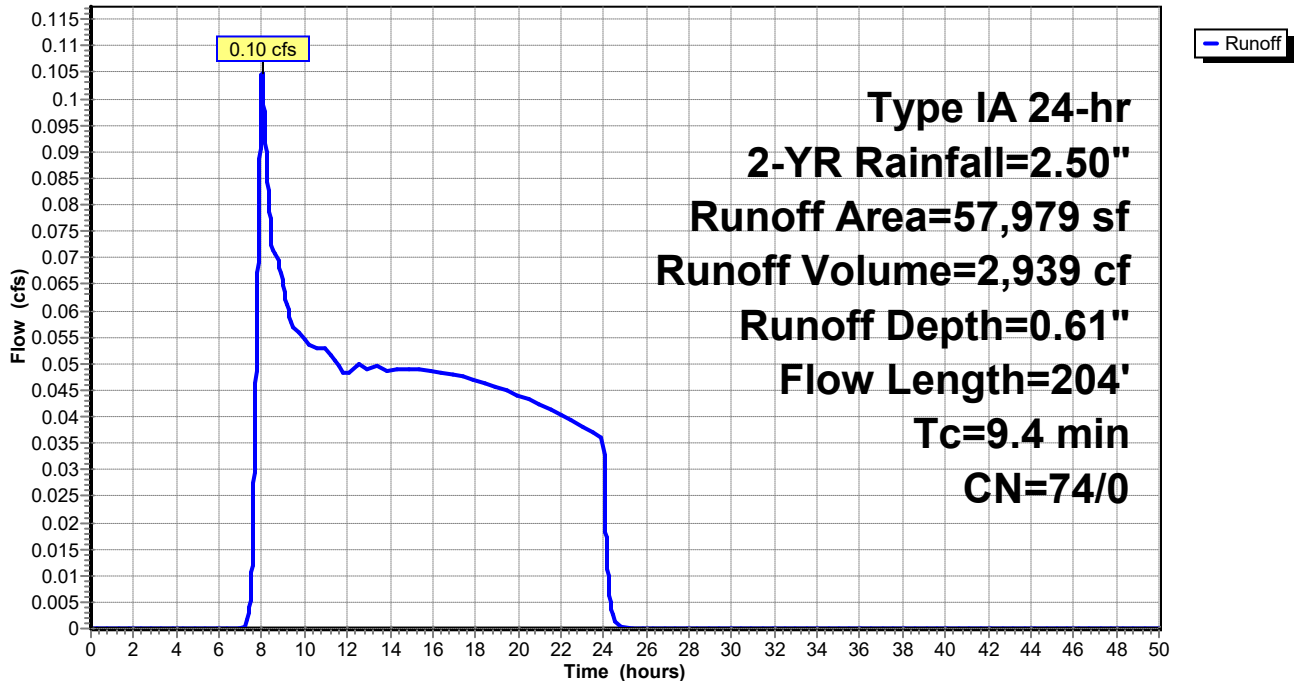

0780-003 HydroCAD Detention & WQ

Prepared by Emerio Design LLC

HydroCAD® 10.00-24 s/n 04804 © 2018 HydroCAD Software Solutions LLC

Type IA 24-hr 2-YR Rainfall=2.50"

Printed 5/25/2021

Page 4

Summary for Subcatchment 101: Pre-Developed Undetained

Runoff = 0.04 cfs @ 8.00 hrs, Volume= 1,111 cf, Depth= 0.63"

Runoff by SBUH method, Split Pervious/Imperv., Time Span= 0.00-50.00 hrs, dt= 0.01 hrs
Type IA 24-hr 2-YR Rainfall=2.50"

	Area (sf)	CN	Description
*	20,912	74	Pervious
*	270	98	Impervious
	21,182	74	Weighted Average
	20,912	74	98.73% Pervious Area
	270	98	1.27% Impervious Area

Tc (min)	Length (feet)	Slope (ft/ft)	Velocity (ft/sec)	Capacity (cfs)	Description
6.0	50	0.0230	0.14		Sheet Flow, Grass: Short n= 0.150 P2= 2.50"
0.9	56	0.0230	1.06		Shallow Concentrated Flow, Short Grass Pasture Kv= 7.0 fps
6.9	106	Total			

Subcatchment 101: Pre-Developed Undetained

Hydrograph

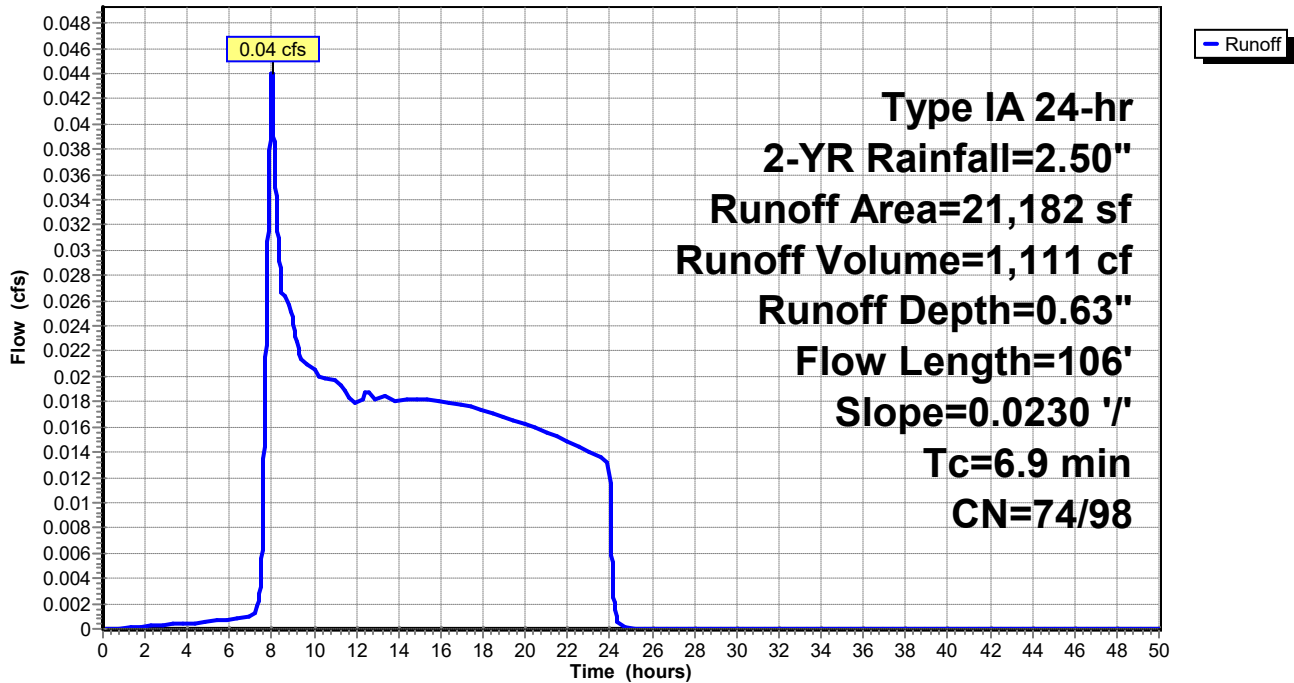

0780-003 HydroCAD Detention & WQ

Type IA 24-hr 2-YR Rainfall=2.50"

Prepared by Emerio Design LLC

Printed 5/25/2021

HydroCAD® 10.00-24 s/n 04804 © 2018 HydroCAD Software Solutions LLC

Page 5

Summary for Subcatchment 200: Post-developed Onsite Detained

Runoff = 0.58 cfs @ 7.91 hrs, Volume= 8,597 cf, Depth= 1.78"

Runoff by SBUH method, Split Pervious/Imperv., Time Span= 0.00-50.00 hrs, dt= 0.01 hrs
 Type IA 24-hr 2-YR Rainfall=2.50"

	Area (sf)	CN	Description
*	30,242	98	Impervious
*	27,737	86	Pervious
	57,979	92	Weighted Average
	27,737	86	47.84% Pervious Area
	30,242	98	52.16% Impervious Area

Tc (min)	Length (feet)	Slope (ft/ft)	Velocity (ft/sec)	Capacity (cfs)	Description
5.0					Direct Entry,

Subcatchment 200: Post-developed Onsite Detained

Hydrograph

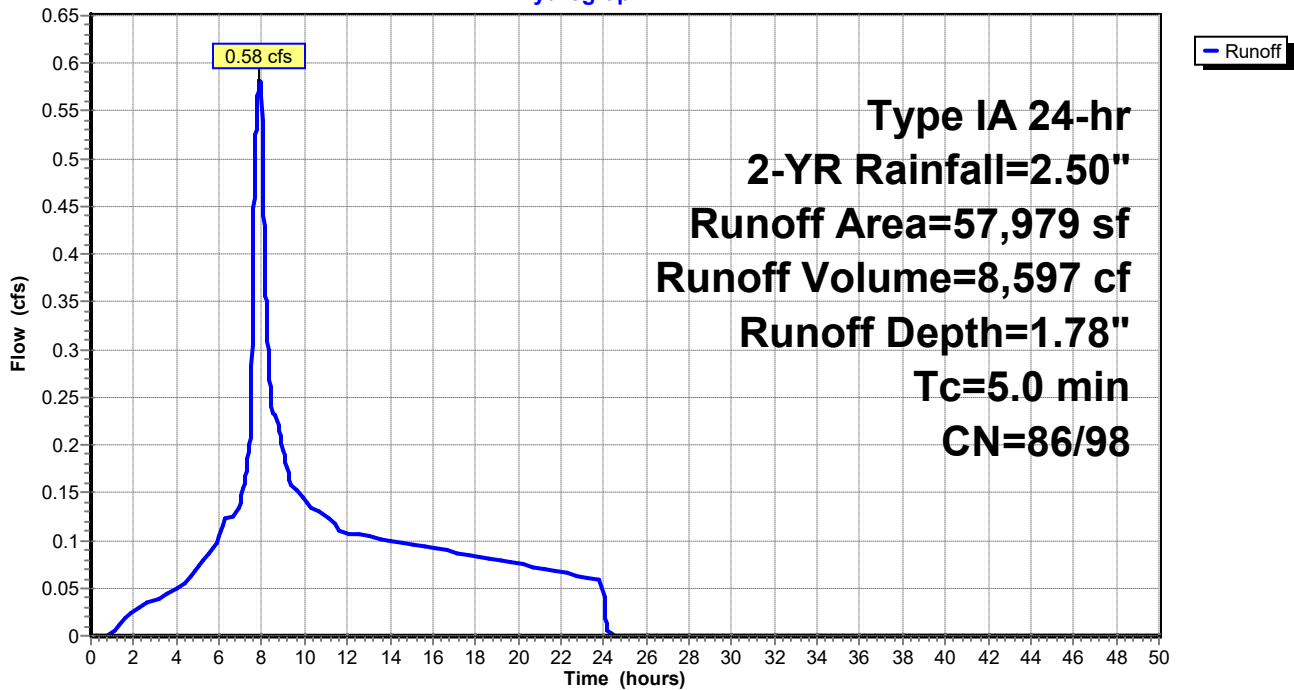

0780-003 HydroCAD Detention & WQ

Type IA 24-hr 2-YR Rainfall=2.50"

Prepared by Emerio Design LLC

Printed 5/25/2021

HydroCAD® 10.00-24 s/n 04804 © 2018 HydroCAD Software Solutions LLC

Page 6

Summary for Subcatchment 201: Undetained Development

Runoff = 0.24 cfs @ 7.90 hrs, Volume= 3,431 cf, Depth= 1.94"

Runoff by SBUH method, Split Pervious/Imperv., Time Span= 0.00-50.00 hrs, dt= 0.01 hrs
Type IA 24-hr 2-YR Rainfall=2.50"

	Area (sf)	CN	Description
*	14,434	98	Impervious
*	6,748	86	Pervious
	21,182	94	Weighted Average
	6,748	86	31.86% Pervious Area
	14,434	98	68.14% Impervious Area

Tc (min)	Length (feet)	Slope (ft/ft)	Velocity (ft/sec)	Capacity (cfs)	Description
5.0					Direct Entry,

Subcatchment 201: Undetained Development

Hydrograph

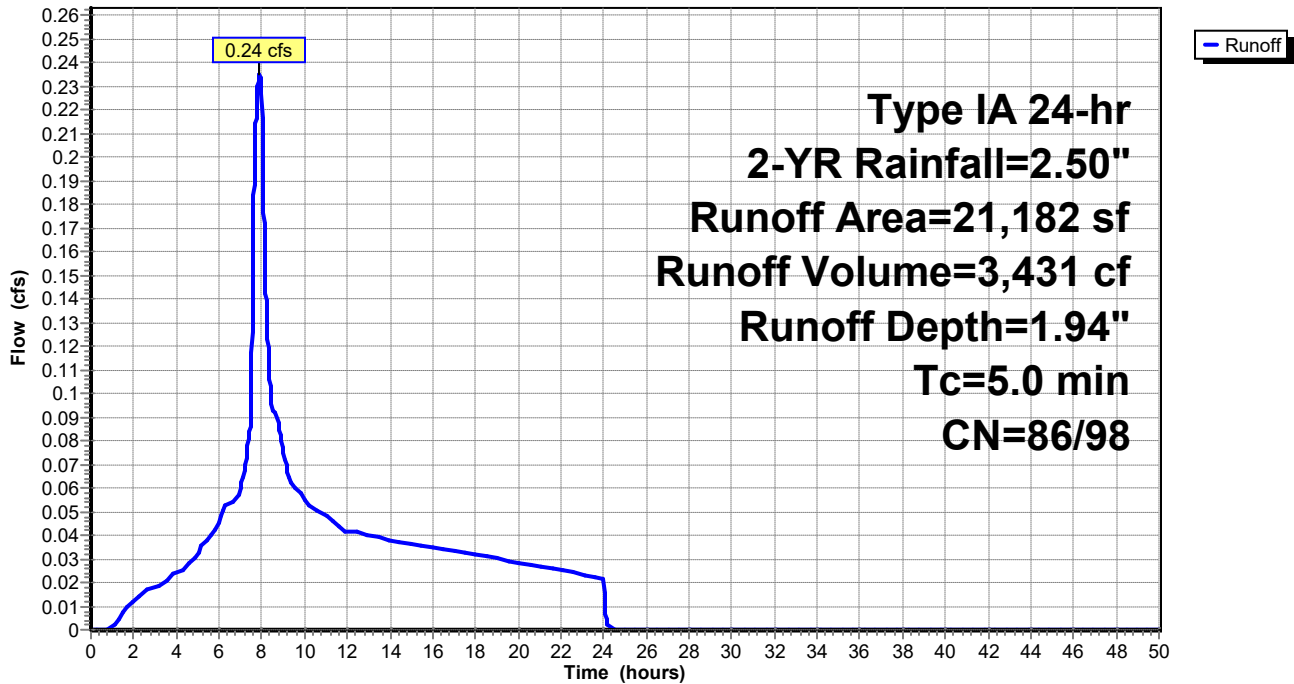

0780-003 HydroCAD Detention & WQ

Type IA 24-hr 2-YR Rainfall=2.50"

Prepared by Emerio Design LLC

Printed 5/25/2021

HydroCAD® 10.00-24 s/n 04804 © 2018 HydroCAD Software Solutions LLC

Page 7

Summary for Subcatchment 201a: Upstream

Runoff = 0.93 cfs @ 7.92 hrs, Volume= 13,880 cf, Depth= 1.66"

Runoff by SBUH method, Split Pervious/Imperv., Time Span= 0.00-50.00 hrs, dt= 0.01 hrs
Type IA 24-hr 2-YR Rainfall=2.50"

	Area (sf)	CN	Description
*	40,551	98	Impervious
*	59,896	86	Pervious
	100,447	91	Weighted Average
	59,896	86	59.63% Pervious Area
	40,551	98	40.37% Impervious Area

Tc (min)	Length (feet)	Slope (ft/ft)	Velocity (ft/sec)	Capacity (cfs)	Description
5.0					Direct Entry,

Subcatchment 201a: Upstream

Hydrograph

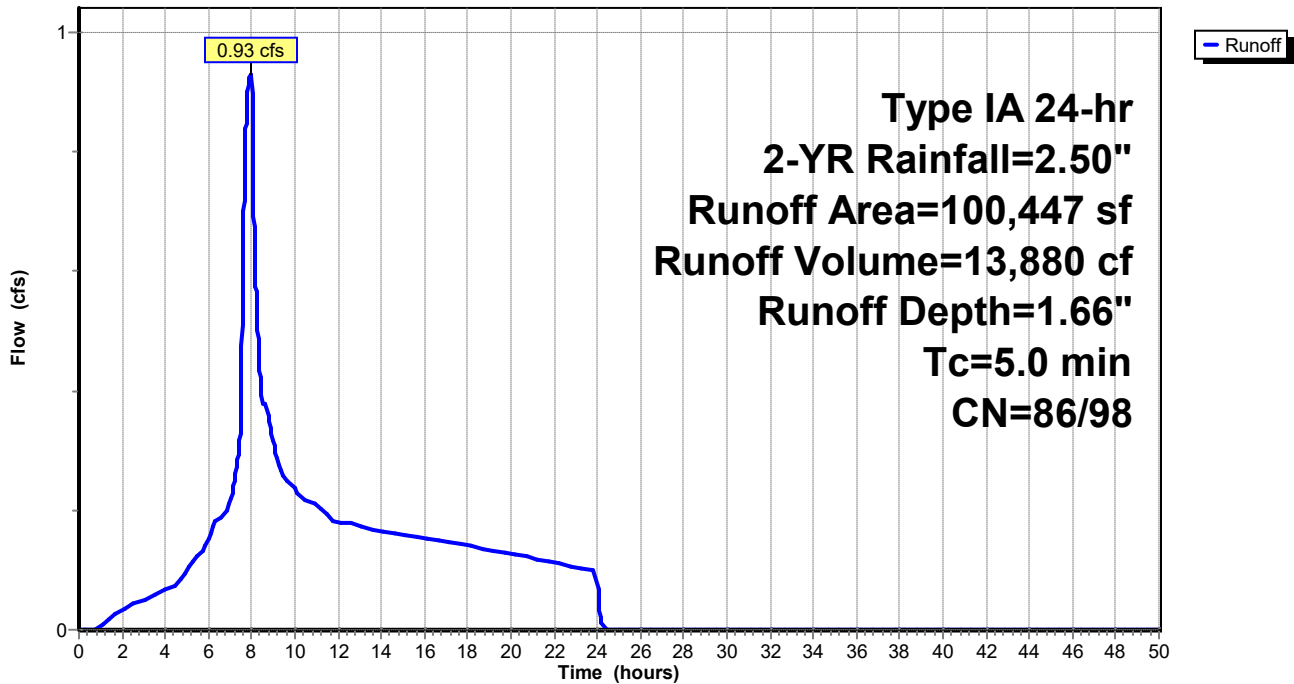

0780-003 HydroCAD Detention & WQ

Type IA 24-hr 2-YR Rainfall=2.50"

Prepared by Emerio Design LLC

Printed 5/25/2021

HydroCAD® 10.00-24 s/n 04804 © 2018 HydroCAD Software Solutions LLC

Page 8

Summary for Subcatchment 201b: Upstream

Runoff = 0.93 cfs @ 7.92 hrs, Volume= 13,880 cf, Depth= 1.66"

Runoff by SBUH method, Split Pervious/Imperv., Time Span= 0.00-50.00 hrs, dt= 0.01 hrs
Type IA 24-hr 2-YR Rainfall=2.50"

	Area (sf)	CN	Description
*	40,551	98	Impervious
*	59,896	86	Pervious
	100,447	91	Weighted Average
	59,896	86	59.63% Pervious Area
	40,551	98	40.37% Impervious Area

Tc (min)	Length (feet)	Slope (ft/ft)	Velocity (ft/sec)	Capacity (cfs)	Description
5.0					Direct Entry,

Subcatchment 201b: Upstream

Hydrograph

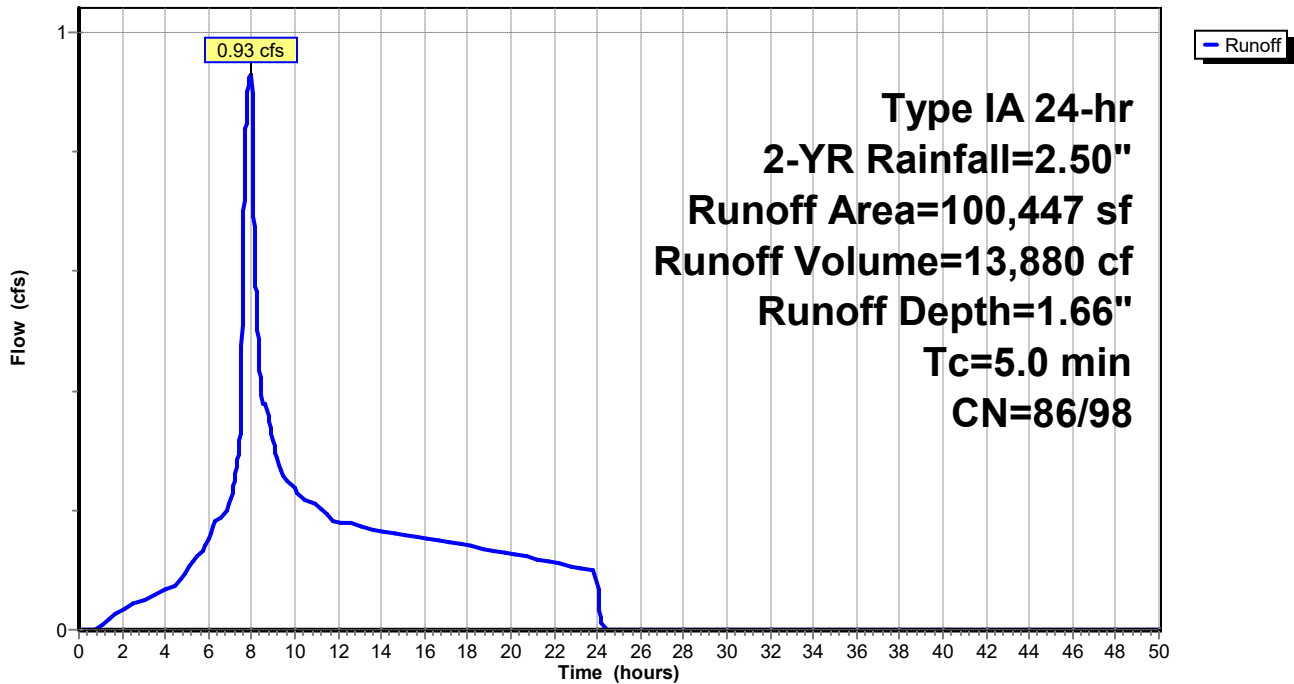

0780-003 HydroCAD Detention & WQ

Type IA 24-hr 2-YR Rainfall=2.50"

Prepared by Emerio Design LLC

Printed 5/25/2021

HydroCAD® 10.00-24 s/n 04804 © 2018 HydroCAD Software Solutions LLC

Page 9

Summary for Pond P1: Onsite Pond

Inflow Area = 158,426 sf, 44.69% Impervious, Inflow Depth = 1.70" for 2-YR event
 Inflow = 1.51 cfs @ 7.92 hrs, Volume= 22,477 cf
 Outflow = 0.61 cfs @ 8.66 hrs, Volume= 22,477 cf, Atten= 60%, Lag= 44.4 min
 Primary = 0.61 cfs @ 8.66 hrs, Volume= 22,477 cf

Routing by Stor-Ind method, Time Span= 0.00-50.00 hrs, dt= 0.01 hrs
 Peak Elev= 201.47' @ 8.66 hrs Surf.Area= 1,516 sf Storage= 2,496 cf

Plug-Flow detention time= 42.8 min calculated for 22,472 cf (100% of inflow)
 Center-of-Mass det. time= 42.8 min (767.5 - 724.7)

Volume	Invert	Avail.Storage	Storage Description
#1	199.70'	6,697 cf	Custom Stage Data (Prismatic) Listed below (Recalc)
Elevation (feet)	Surf.Area (sq-ft)	Inc.Store (cubic-feet)	Cum.Store (cubic-feet)
199.70	1,301	0	0
200.00	1,339	396	396
201.00	1,462	1,401	1,797
202.00	1,577	1,520	3,316
203.00	1,686	1,632	4,948
203.50	1,750	859	5,807
204.00	1,813	891	6,697

Device	Routing	Invert	Outlet Devices
#1	Primary	197.70'	12.0" Round Outlet Pipe L= 40.0' CMP, square edge headwall, Ke= 0.500 Inlet / Outlet Invert= 197.70' / 197.50' S= 0.0050 '/' Cc= 0.900 n= 0.013, Flow Area= 0.79 sf
#2	Device 1	198.00'	3.3" Vert. Low Orifice C= 0.620
#3	Device 2	200.05'	24.0" x 24.0" Horiz. Low Grate Inlet C= 0.620 Limited to weir flow at low heads
#4	Device 1	201.85'	5.7" Vert. High Orifice C= 0.620
#5	Device 1	199.70'	2.000 in/hr Growing Media Infiltration over Surface area above 197.70' Excluded Surface area = 0 sf

Primary OutFlow Max=0.61 cfs @ 8.66 hrs HW=201.47' (Free Discharge)

- 1=Outlet Pipe (Passes 0.61 cfs of 6.54 cfs potential flow)
- 2=Low Orifice (Orifice Controls 0.54 cfs @ 9.08 fps)
- 3=Low Grate Inlet (Passes 0.54 cfs of 23.71 cfs potential flow)
- 4=High Orifice (Controls 0.00 cfs)
- 5=Growing Media Infiltration (Exfiltration Controls 0.07 cfs)

Pond P1: Onsite Pond

Hydrograph

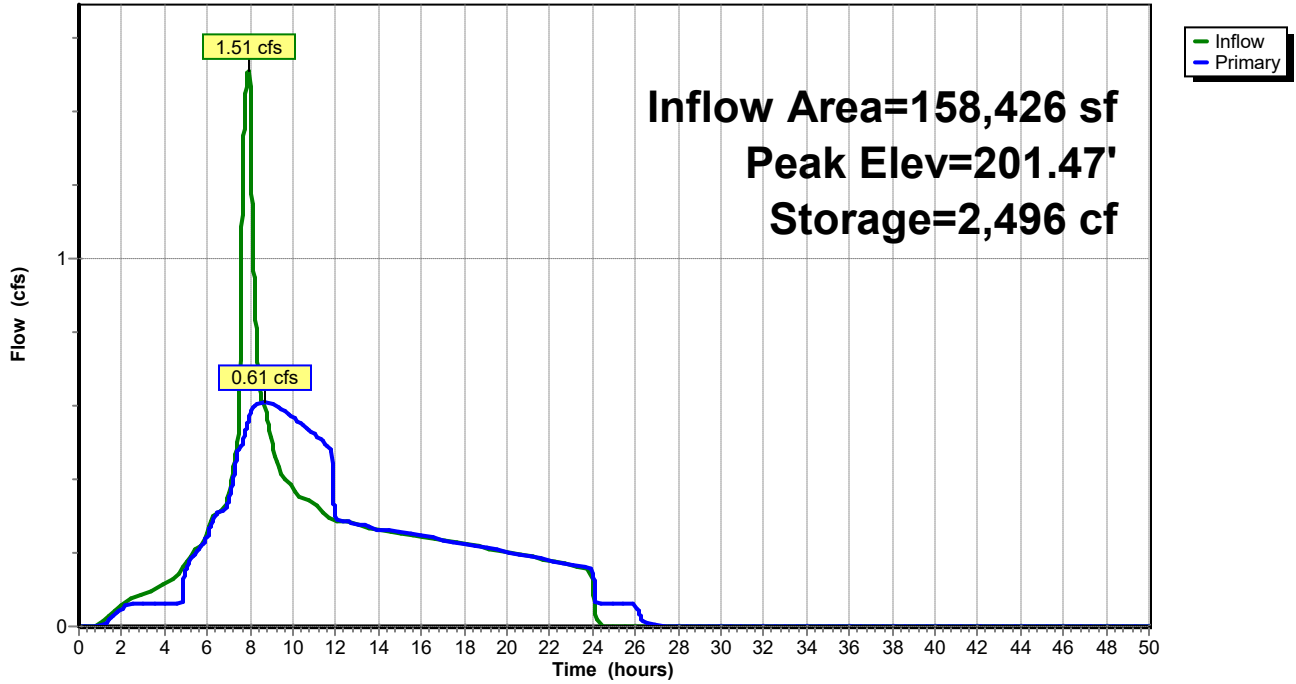

Summary for Link L1: Pre-Developed and Offsite Flows

Inflow Area = 179,608 sf, 22.73% Impervious, Inflow Depth = 1.20" for 2-YR event
Inflow = 1.07 cfs @ 7.97 hrs, Volume= 17,930 cf
Primary = 1.07 cfs @ 7.97 hrs, Volume= 17,930 cf, Atten= 0%, Lag= 0.0 min

Primary outflow = Inflow, Time Span= 0.00-50.00 hrs, dt= 0.01 hrs

Link L1: Pre-Developed and Offsite Flows

Hydrograph

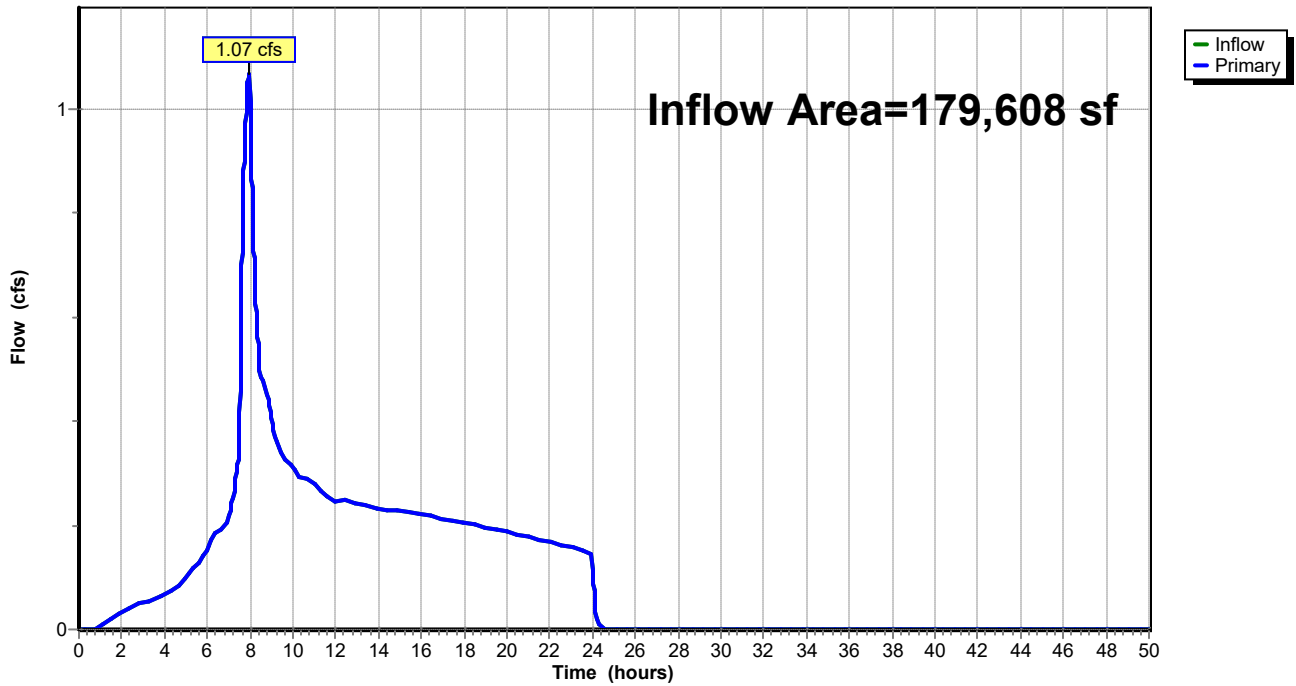

Summary for Link L2: Post-Developed and Offsite Flows

Inflow Area = 179,608 sf, 47.45% Impervious, Inflow Depth = 1.73" for 2-YR event
Inflow = 0.81 cfs @ 8.00 hrs, Volume= 25,907 cf
Primary = 0.81 cfs @ 8.00 hrs, Volume= 25,907 cf, Atten= 0%, Lag= 0.0 min

Primary outflow = Inflow, Time Span= 0.00-50.00 hrs, dt= 0.01 hrs

Link L2: Post-Developed and Offsite Flows

Hydrograph

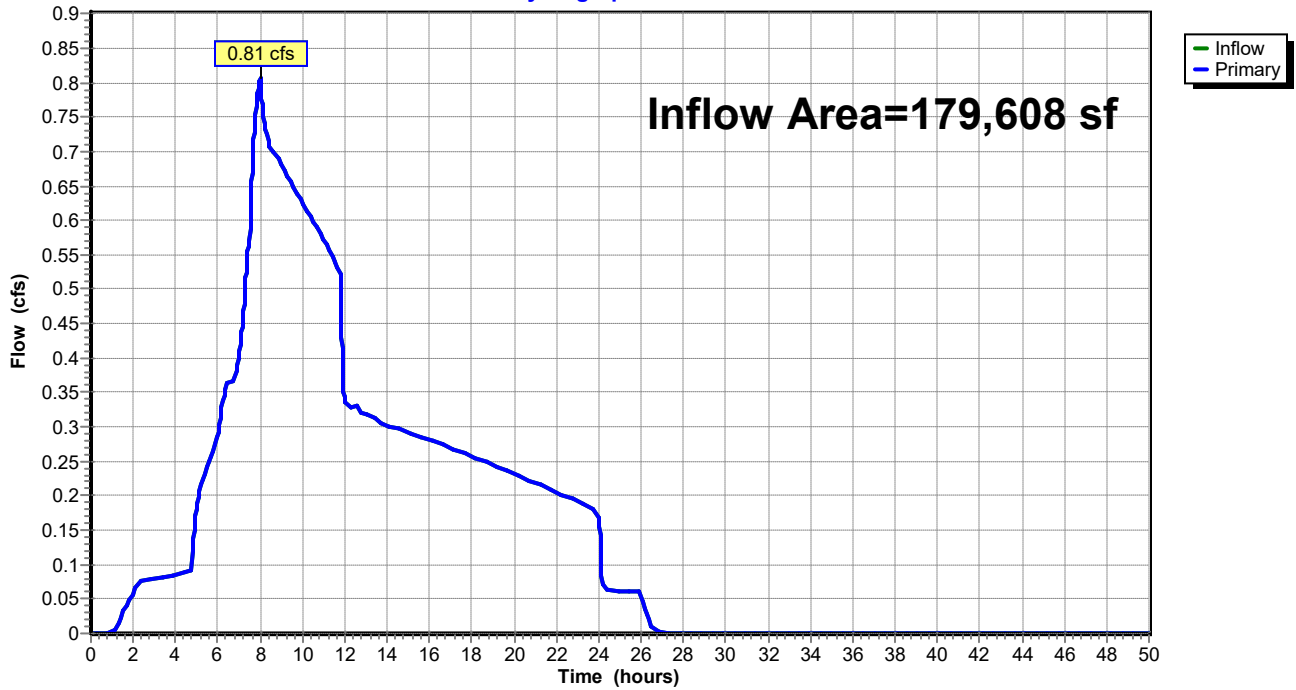

0780-003 HydroCAD Detention & WQ

Type IA 24-hr 10-YR Rainfall=3.50"

Prepared by Emerio Design LLC

Printed 5/25/2021

HydroCAD® 10.00-24 s/n 04804 © 2018 HydroCAD Software Solutions LLC

Page 13

Summary for Subcatchment 100: Pre-developed Onsite Detained

Runoff = 0.31 cfs @ 8.00 hrs, Volume= 5,991 cf, Depth= 1.24"

Runoff by SBUH method, Split Pervious/Imperv., Time Span= 0.00-50.00 hrs, dt= 0.01 hrs
Type IA 24-hr 10-YR Rainfall=3.50"

Area (sf)	CN	Description
* 57,979	74	Pervious
57,979	74	100.00% Pervious Area

Tc (min)	Length (feet)	Slope (ft/ft)	Velocity (ft/sec)	Capacity (cfs)	Description
6.8	50	0.0170	0.12		Sheet Flow, Grass: Short n= 0.150 P2= 2.50"
2.6	154	0.0195	0.98		Shallow Concentrated Flow, Short Grass Pasture Kv= 7.0 fps
9.4	204	Total			

Subcatchment 100: Pre-developed Onsite Detained

Hydrograph

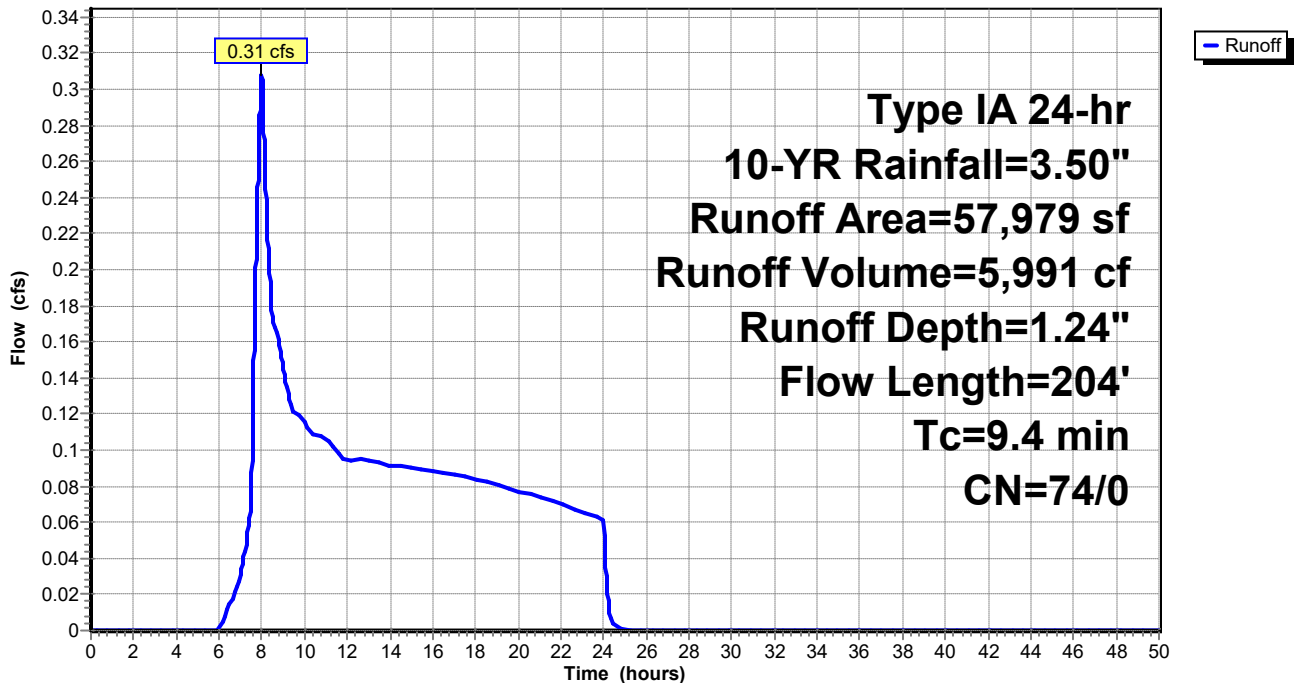

0780-003 HydroCAD Detention & WQ

Type IA 24-hr 10-YR Rainfall=3.50"

Prepared by Emerio Design LLC

Printed 5/25/2021

HydroCAD® 10.00-24 s/n 04804 © 2018 HydroCAD Software Solutions LLC

Page 14

Summary for Subcatchment 101: Pre-Developed Undetained

Runoff = 0.12 cfs @ 8.00 hrs, Volume= 2,234 cf, Depth= 1.27"

Runoff by SBUH method, Split Pervious/Imperv., Time Span= 0.00-50.00 hrs, dt= 0.01 hrs
Type IA 24-hr 10-YR Rainfall=3.50"

	Area (sf)	CN	Description
*	20,912	74	Pervious
*	270	98	Impervious
	21,182	74	Weighted Average
	20,912	74	98.73% Pervious Area
	270	98	1.27% Impervious Area

Tc (min)	Length (feet)	Slope (ft/ft)	Velocity (ft/sec)	Capacity (cfs)	Description
6.0	50	0.0230	0.14		Sheet Flow, Grass: Short n= 0.150 P2= 2.50"
0.9	56	0.0230	1.06		Shallow Concentrated Flow, Short Grass Pasture Kv= 7.0 fps
6.9	106	Total			

Subcatchment 101: Pre-Developed Undetained

Hydrograph

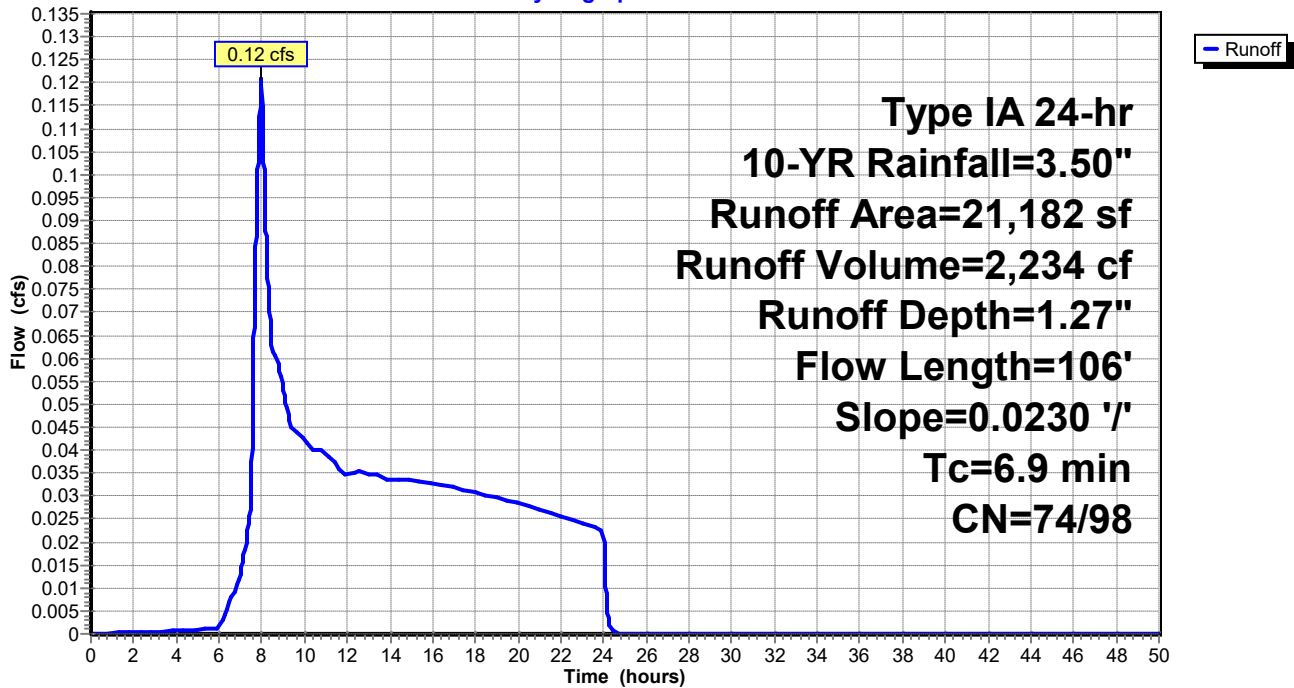

0780-003 HydroCAD Detention & WQ

Type IA 24-hr 10-YR Rainfall=3.50"

Prepared by Emerio Design LLC

Printed 5/25/2021

HydroCAD® 10.00-24 s/n 04804 © 2018 HydroCAD Software Solutions LLC

Page 15

Summary for Subcatchment 200: Post-developed Onsite Detained

Runoff = 0.90 cfs @ 7.90 hrs, Volume= 13,082 cf, Depth= 2.71"

Runoff by SBUH method, Split Pervious/Imperv., Time Span= 0.00-50.00 hrs, dt= 0.01 hrs
Type IA 24-hr 10-YR Rainfall=3.50"

	Area (sf)	CN	Description
*	30,242	98	Impervious
*	27,737	86	Pervious
	57,979	92	Weighted Average
	27,737	86	47.84% Pervious Area
	30,242	98	52.16% Impervious Area

Tc (min)	Length (feet)	Slope (ft/ft)	Velocity (ft/sec)	Capacity (cfs)	Description
5.0					Direct Entry,

Subcatchment 200: Post-developed Onsite Detained

Hydrograph

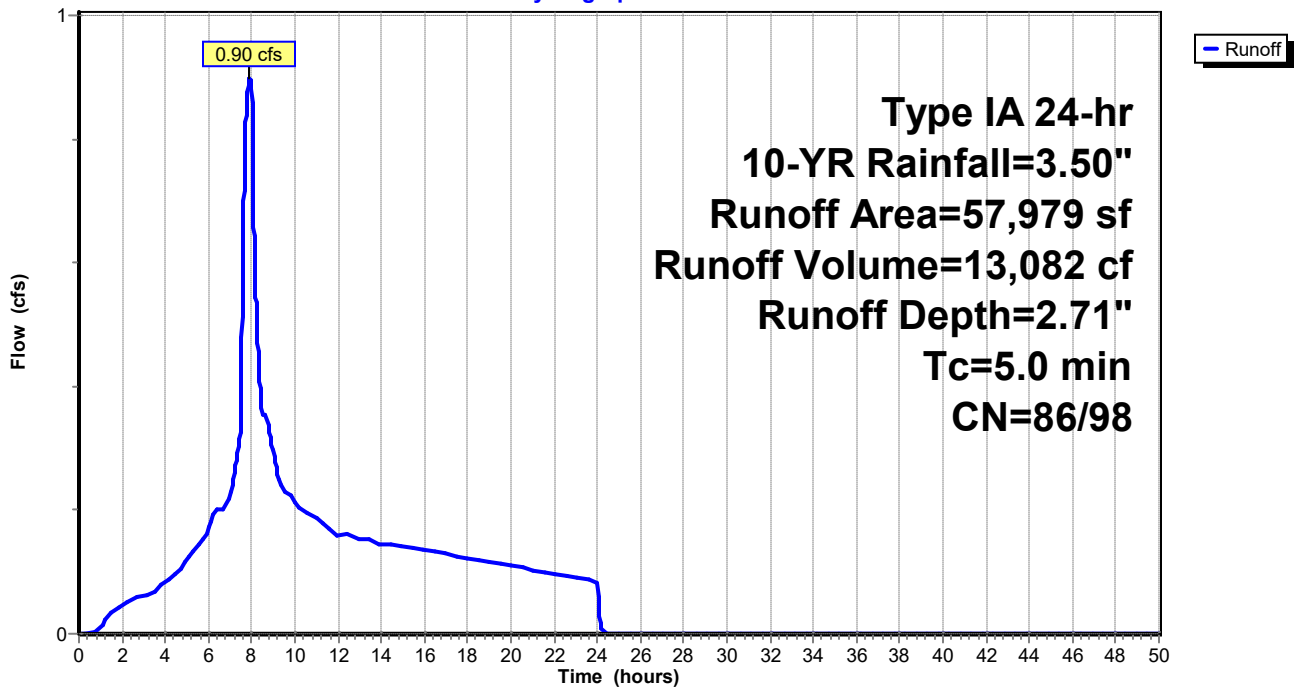

0780-003 HydroCAD Detention & WQ

Type IA 24-hr 10-YR Rainfall=3.50"

Prepared by Emerio Design LLC

Printed 5/25/2021

HydroCAD® 10.00-24 s/n 04804 © 2018 HydroCAD Software Solutions LLC

Page 16

Summary for Subcatchment 201: Undetained Development

Runoff = 0.35 cfs @ 7.89 hrs, Volume= 5,109 cf, Depth= 2.89"

Runoff by SBUH method, Split Pervious/Imperv., Time Span= 0.00-50.00 hrs, dt= 0.01 hrs
Type IA 24-hr 10-YR Rainfall=3.50"

	Area (sf)	CN	Description
*	14,434	98	Impervious
*	6,748	86	Pervious
	21,182	94	Weighted Average
	6,748	86	31.86% Pervious Area
	14,434	98	68.14% Impervious Area

Tc (min)	Length (feet)	Slope (ft/ft)	Velocity (ft/sec)	Capacity (cfs)	Description
5.0					Direct Entry,

Subcatchment 201: Undetained Development

Hydrograph

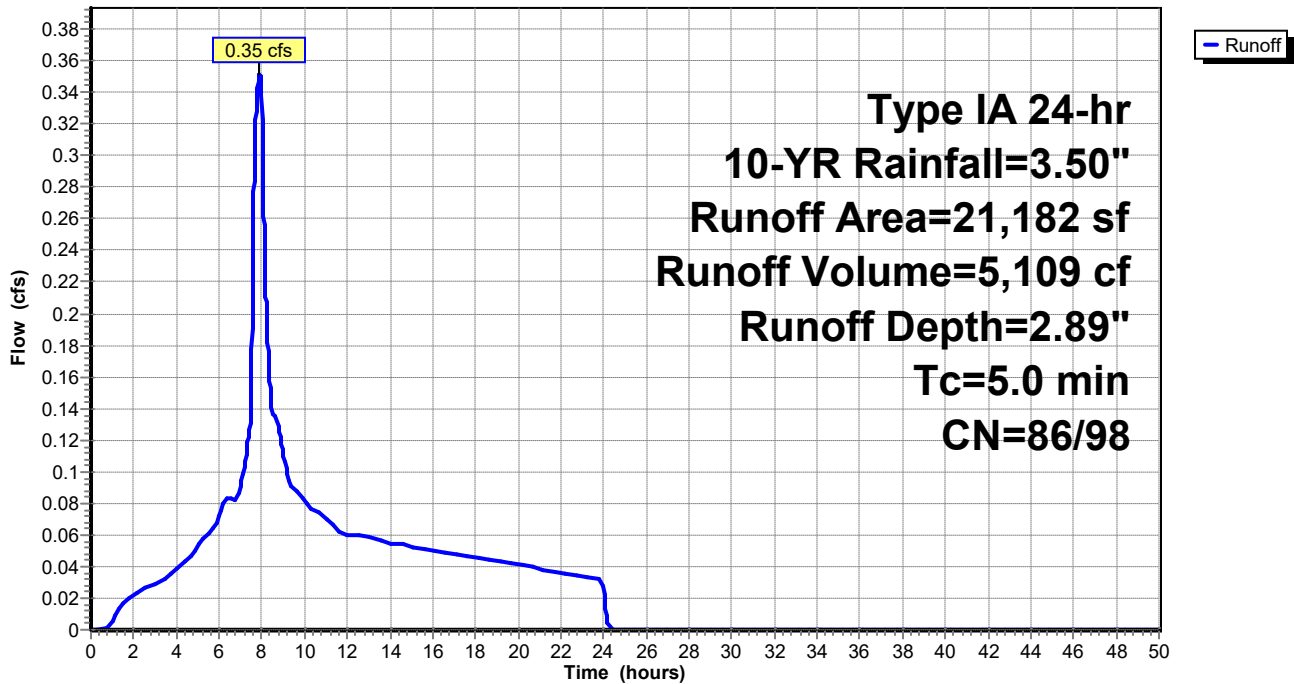

0780-003 HydroCAD Detention & WQ

Type IA 24-hr 10-YR Rainfall=3.50"

Prepared by Emerio Design LLC

Printed 5/25/2021

HydroCAD® 10.00-24 s/n 04804 © 2018 HydroCAD Software Solutions LLC

Page 17

Summary for Subcatchment 201a: Upstream

Runoff = 1.47 cfs @ 7.91 hrs, Volume= 21,512 cf, Depth= 2.57"

Runoff by SBUH method, Split Pervious/Imperv., Time Span= 0.00-50.00 hrs, dt= 0.01 hrs
 Type IA 24-hr 10-YR Rainfall=3.50"

	Area (sf)	CN	Description
*	40,551	98	Impervious
*	59,896	86	Pervious
	100,447	91	Weighted Average
	59,896	86	59.63% Pervious Area
	40,551	98	40.37% Impervious Area

Tc (min)	Length (feet)	Slope (ft/ft)	Velocity (ft/sec)	Capacity (cfs)	Description
5.0					Direct Entry,

Subcatchment 201a: Upstream

Hydrograph

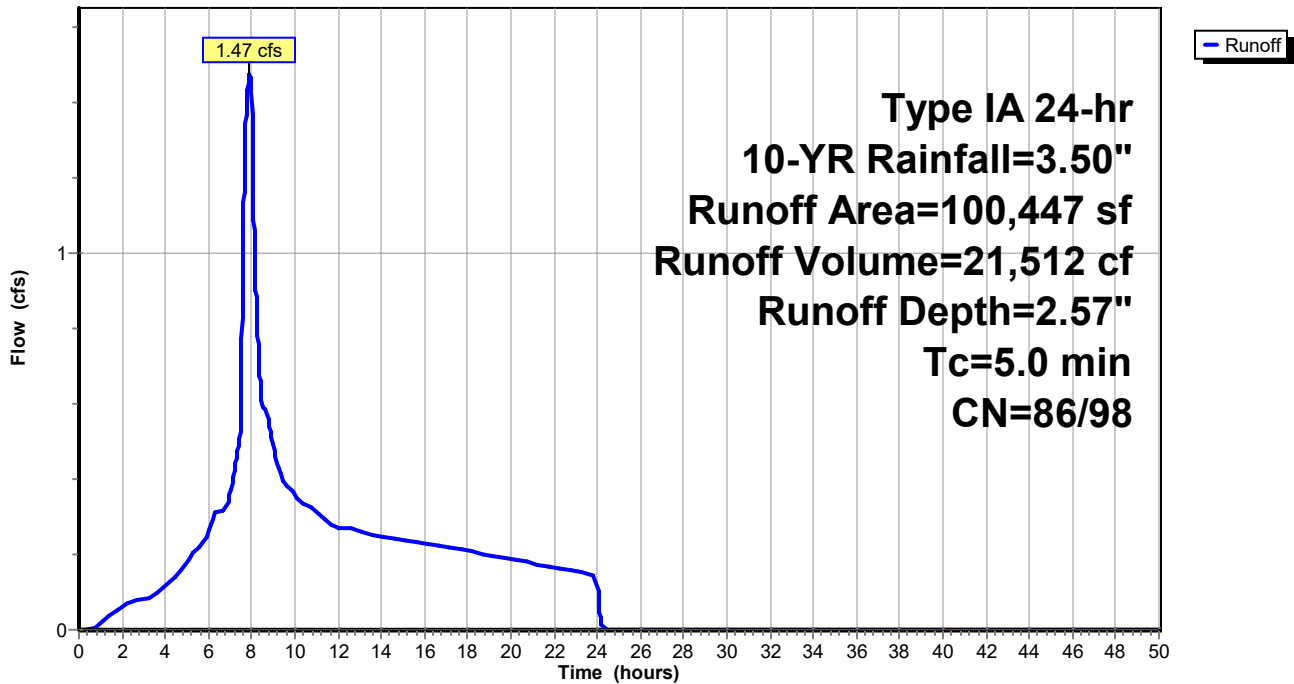

0780-003 HydroCAD Detention & WQ

Type IA 24-hr 10-YR Rainfall=3.50"

Prepared by Emerio Design LLC

Printed 5/25/2021

HydroCAD® 10.00-24 s/n 04804 © 2018 HydroCAD Software Solutions LLC

Page 18

Summary for Subcatchment 201b: Upstream

Runoff = 1.47 cfs @ 7.91 hrs, Volume= 21,512 cf, Depth= 2.57"

Runoff by SBUH method, Split Pervious/Imperv., Time Span= 0.00-50.00 hrs, dt= 0.01 hrs
Type IA 24-hr 10-YR Rainfall=3.50"

	Area (sf)	CN	Description
*	40,551	98	Impervious
*	59,896	86	Pervious
	100,447	91	Weighted Average
	59,896	86	59.63% Pervious Area
	40,551	98	40.37% Impervious Area

Tc (min)	Length (feet)	Slope (ft/ft)	Velocity (ft/sec)	Capacity (cfs)	Description
5.0					Direct Entry,

Subcatchment 201b: Upstream

Hydrograph

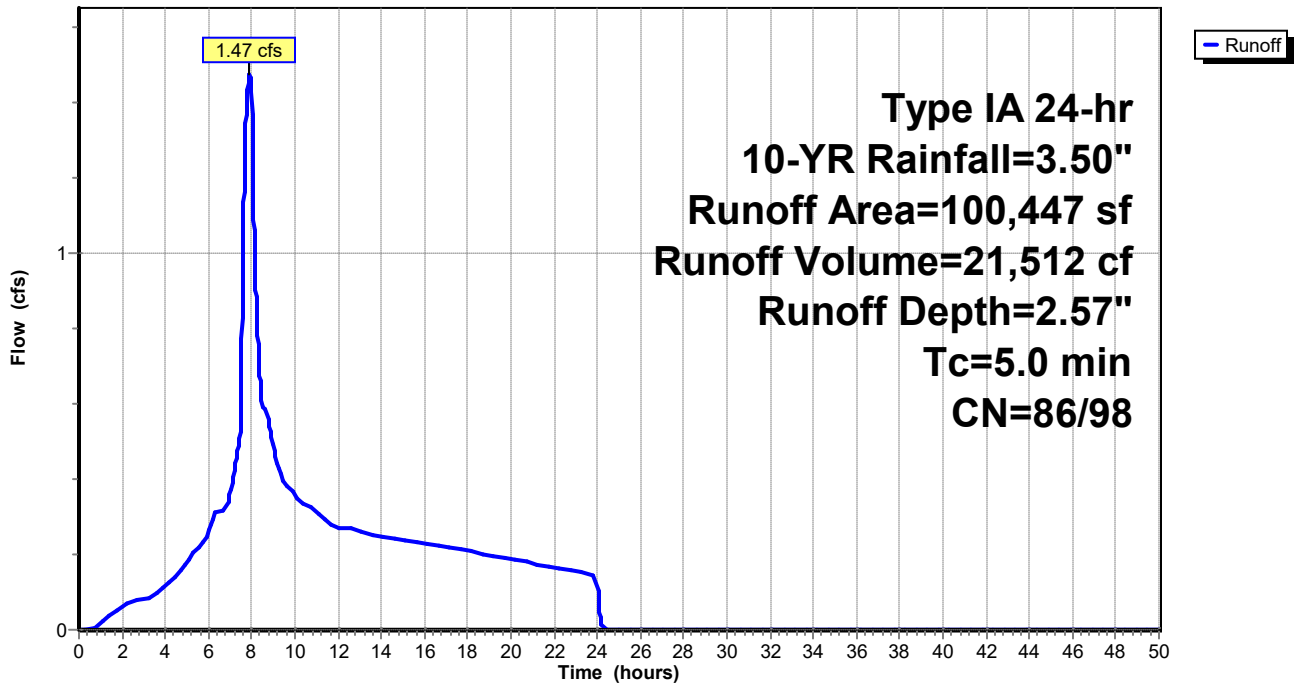

0780-003 HydroCAD Detention & WQ

Type IA 24-hr 10-YR Rainfall=3.50"

Prepared by Emerio Design LLC

Printed 5/25/2021

HydroCAD® 10.00-24 s/n 04804 © 2018 HydroCAD Software Solutions LLC

Page 19

Summary for Pond P1: Onsite Pond

Inflow Area = 158,426 sf, 44.69% Impervious, Inflow Depth = 2.62" for 10-YR event
 Inflow = 2.37 cfs @ 7.91 hrs, Volume= 34,594 cf
 Outflow = 1.25 cfs @ 8.28 hrs, Volume= 34,594 cf, Atten= 47%, Lag= 22.1 min
 Primary = 1.25 cfs @ 8.28 hrs, Volume= 34,594 cf

Routing by Stor-Ind method, Time Span= 0.00-50.00 hrs, dt= 0.01 hrs
 Peak Elev= 202.49' @ 8.28 hrs Surf.Area= 1,630 sf Storage= 4,098 cf

Plug-Flow detention time= 45.9 min calculated for 34,587 cf (100% of inflow)
 Center-of-Mass det. time= 45.9 min (756.3 - 710.4)

Volume	Invert	Avail.Storage	Storage Description
#1	199.70'	6,697 cf	Custom Stage Data (Prismatic) Listed below (Recalc)
Elevation (feet)	Surf.Area (sq-ft)	Inc.Store (cubic-feet)	Cum.Store (cubic-feet)
199.70	1,301	0	0
200.00	1,339	396	396
201.00	1,462	1,401	1,797
202.00	1,577	1,520	3,316
203.00	1,686	1,632	4,948
203.50	1,750	859	5,807
204.00	1,813	891	6,697

Device	Routing	Invert	Outlet Devices
#1	Primary	197.70'	12.0" Round Outlet Pipe L= 40.0' CMP, square edge headwall, Ke= 0.500 Inlet / Outlet Invert= 197.70' / 197.50' S= 0.0050 '/' Cc= 0.900 n= 0.013, Flow Area= 0.79 sf
#2	Device 1	198.00'	3.3" Vert. Low Orifice C= 0.620
#3	Device 2	200.05'	24.0" x 24.0" Horiz. Low Grate Inlet C= 0.620 Limited to weir flow at low heads
#4	Device 1	201.85'	5.7" Vert. High Orifice C= 0.620
#5	Device 1	199.70'	2.000 in/hr Growing Media Infiltration over Surface area above 197.70' Excluded Surface area = 0 sf

Primary OutFlow Max=1.25 cfs @ 8.28 hrs HW=202.49' (Free Discharge)

- 1=Outlet Pipe (Passes 1.25 cfs of 7.58 cfs potential flow)
- 2=Low Orifice (Orifice Controls 0.62 cfs @ 10.38 fps)
- 3=Low Grate Inlet (Passes 0.62 cfs of 31.07 cfs potential flow)
- 4=High Orifice (Orifice Controls 0.56 cfs @ 3.15 fps)
- 5=Growing Media Infiltration (Exfiltration Controls 0.08 cfs)

Pond P1: Onsite Pond

Hydrograph

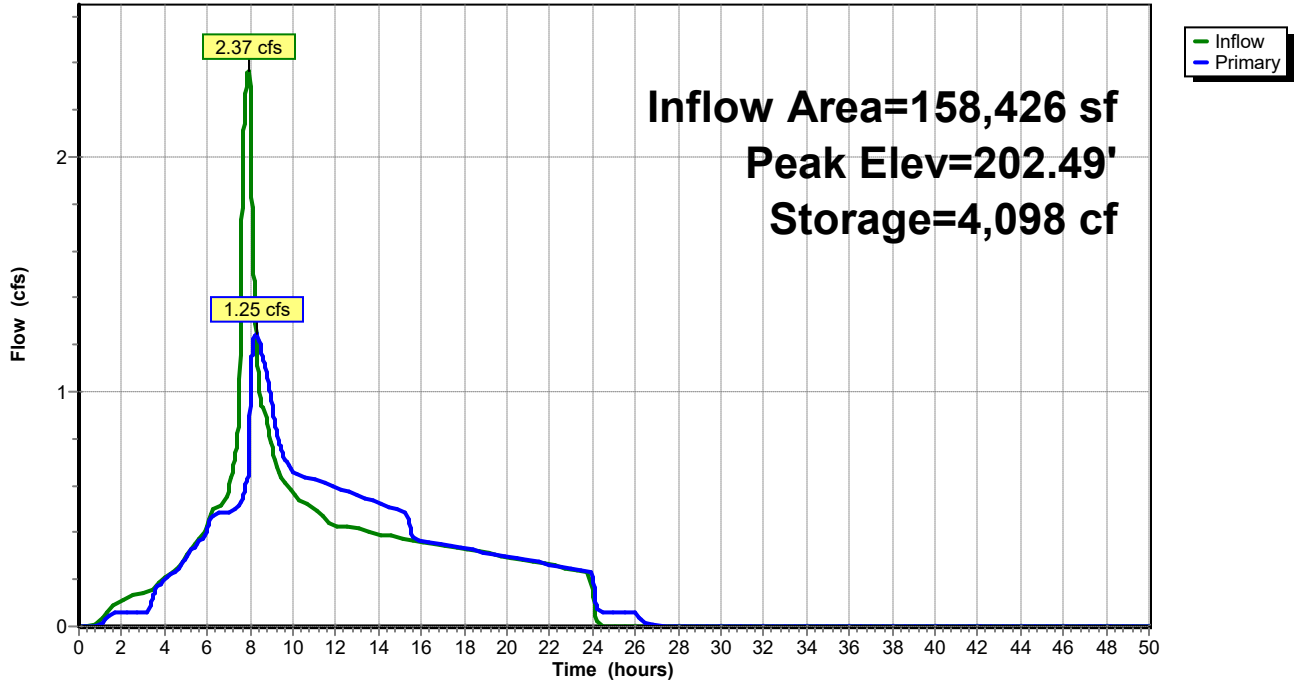

Summary for Link L1: Pre-Developed and Offsite Flows

Inflow Area = 179,608 sf, 22.73% Impervious, Inflow Depth = 1.99" for 10-YR event
Inflow = 1.88 cfs @ 7.95 hrs, Volume= 29,737 cf
Primary = 1.88 cfs @ 7.95 hrs, Volume= 29,737 cf, Atten= 0%, Lag= 0.0 min

Primary outflow = Inflow, Time Span= 0.00-50.00 hrs, dt= 0.01 hrs

Link L1: Pre-Developed and Offsite Flows

Hydrograph

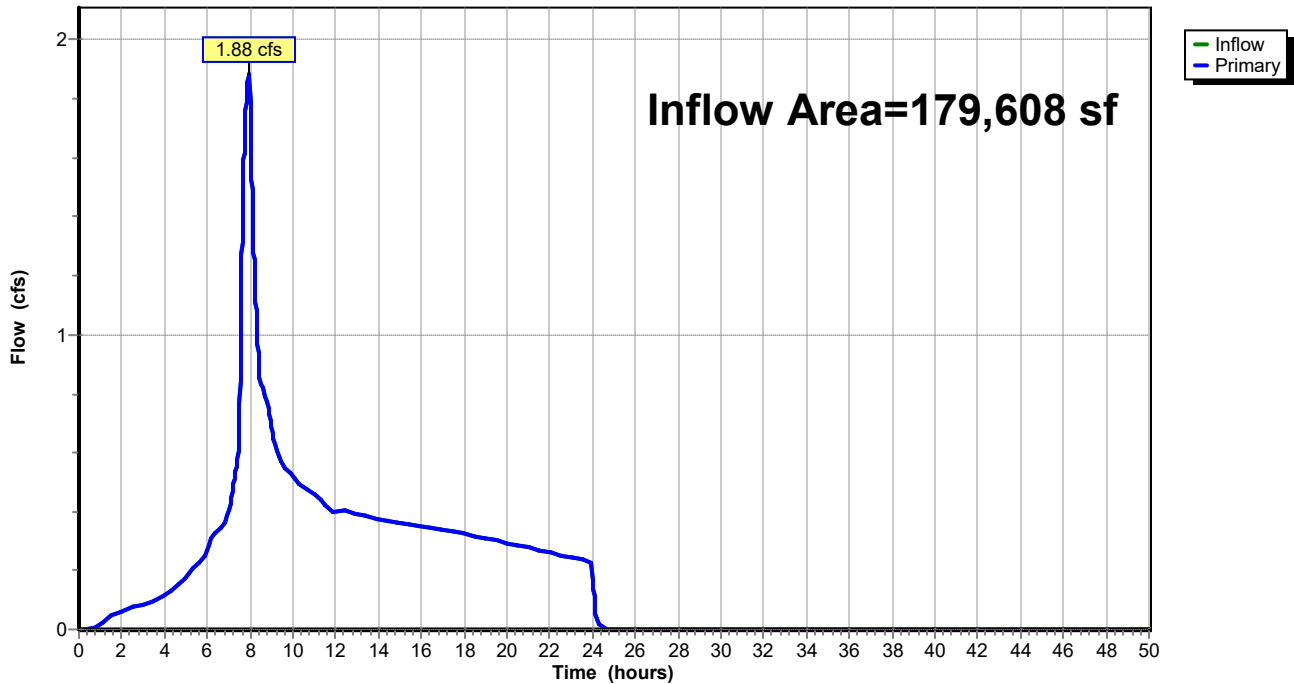

Summary for Link L2: Post-Developed and Offsite Flows

Inflow Area = 179,608 sf, 47.45% Impervious, Inflow Depth = 2.65" for 10-YR event
Inflow = 1.45 cfs @ 8.18 hrs, Volume= 39,703 cf
Primary = 1.45 cfs @ 8.18 hrs, Volume= 39,703 cf, Atten= 0%, Lag= 0.0 min

Primary outflow = Inflow, Time Span= 0.00-50.00 hrs, dt= 0.01 hrs

Link L2: Post-Developed and Offsite Flows

Hydrograph

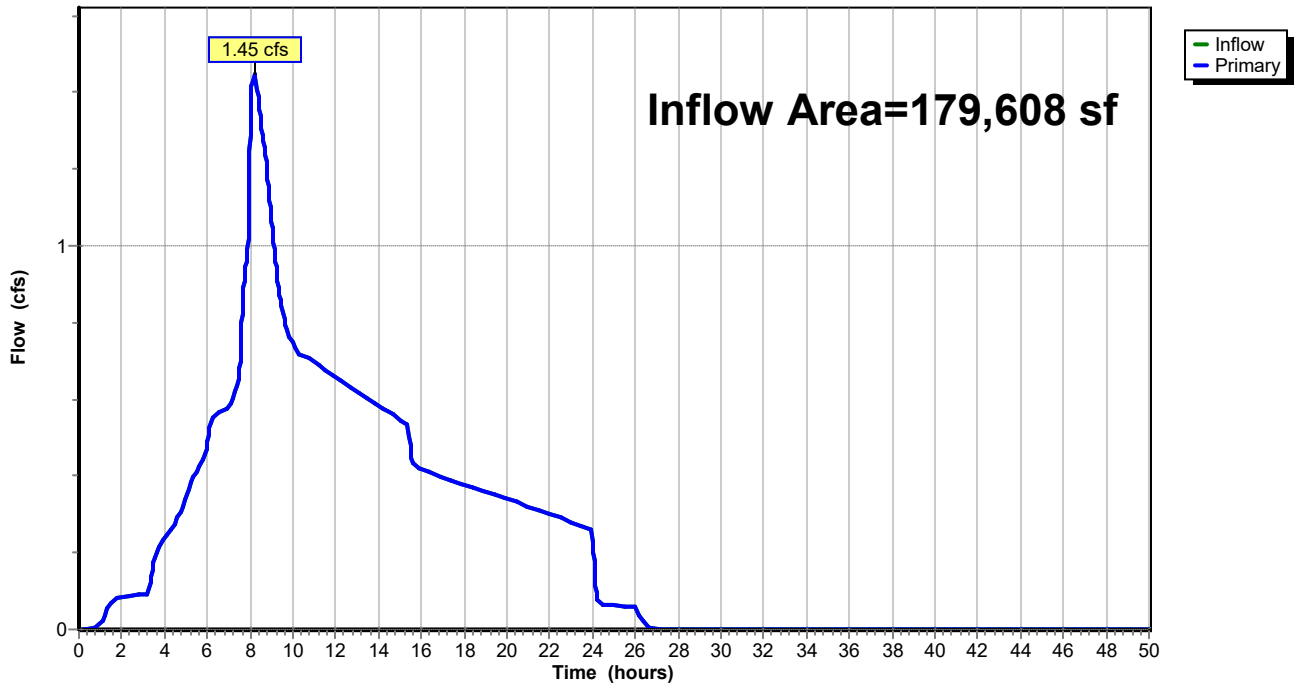

0780-003 HydroCAD Detention & WQ

Type IA 24-hr 25-YR Rainfall=4.00"

Prepared by Emerio Design LLC

Printed 5/25/2021

HydroCAD® 10.00-24 s/n 04804 © 2018 HydroCAD Software Solutions LLC

Page 23

Summary for Subcatchment 100: Pre-developed Onsite Detained

Runoff = 0.43 cfs @ 8.00 hrs, Volume= 7,713 cf, Depth= 1.60"

Runoff by SBUH method, Split Pervious/Imperv., Time Span= 0.00-50.00 hrs, dt= 0.01 hrs
Type IA 24-hr 25-YR Rainfall=4.00"

Area (sf)	CN	Description
* 57,979	74	Pervious
57,979	74	100.00% Pervious Area

Tc (min)	Length (feet)	Slope (ft/ft)	Velocity (ft/sec)	Capacity (cfs)	Description
6.8	50	0.0170	0.12		Sheet Flow, Grass: Short n= 0.150 P2= 2.50"
2.6	154	0.0195	0.98		Shallow Concentrated Flow, Short Grass Pasture Kv= 7.0 fps
9.4	204	Total			

Subcatchment 100: Pre-developed Onsite Detained

Hydrograph

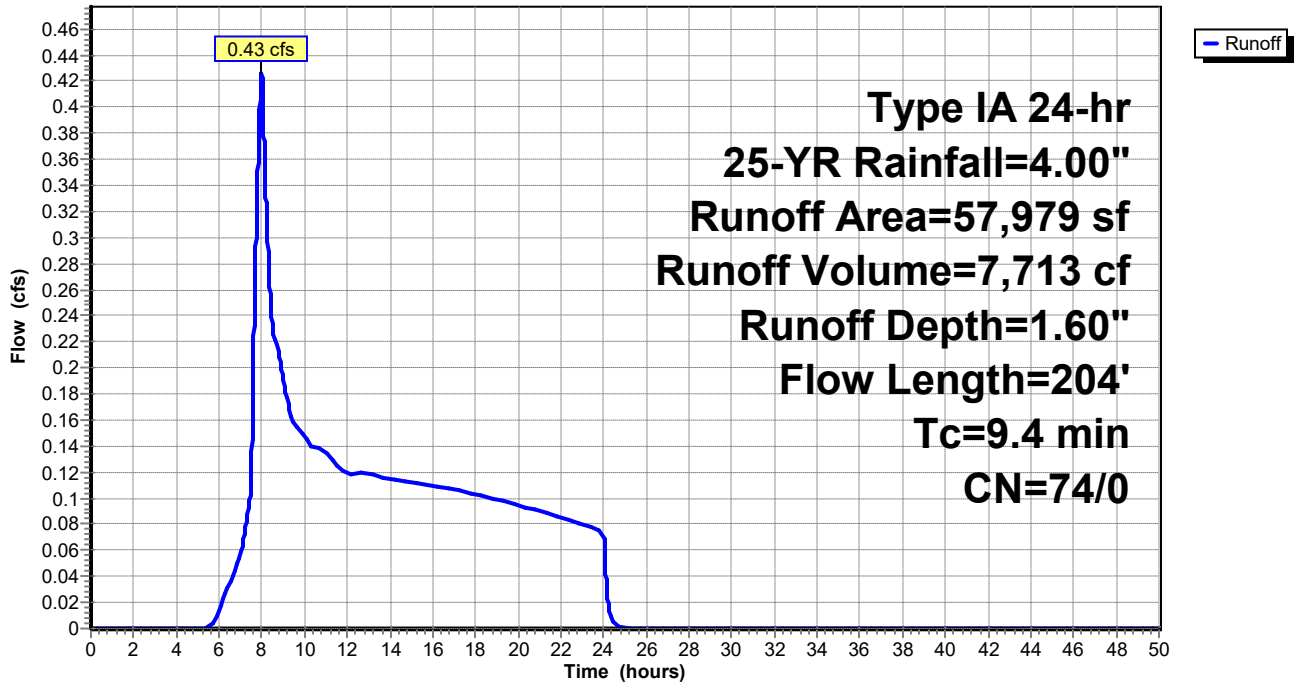

0780-003 HydroCAD Detention & WQ

Type IA 24-hr 25-YR Rainfall=4.00"

Prepared by Emerio Design LLC

Printed 5/25/2021

HydroCAD® 10.00-24 s/n 04804 © 2018 HydroCAD Software Solutions LLC

Page 24

Summary for Subcatchment 101: Pre-Developed Undetained

Runoff = 0.17 cfs @ 8.00 hrs, Volume= 2,867 cf, Depth= 1.62"

Runoff by SBUH method, Split Pervious/Imperv., Time Span= 0.00-50.00 hrs, dt= 0.01 hrs
Type IA 24-hr 25-YR Rainfall=4.00"

	Area (sf)	CN	Description
*	20,912	74	Pervious
*	270	98	Impervious
	21,182	74	Weighted Average
	20,912	74	98.73% Pervious Area
	270	98	1.27% Impervious Area

Tc (min)	Length (feet)	Slope (ft/ft)	Velocity (ft/sec)	Capacity (cfs)	Description
6.0	50	0.0230	0.14		Sheet Flow, Grass: Short n= 0.150 P2= 2.50"
0.9	56	0.0230	1.06		Shallow Concentrated Flow, Short Grass Pasture Kv= 7.0 fps
6.9	106	Total			

Subcatchment 101: Pre-Developed Undetained

Hydrograph

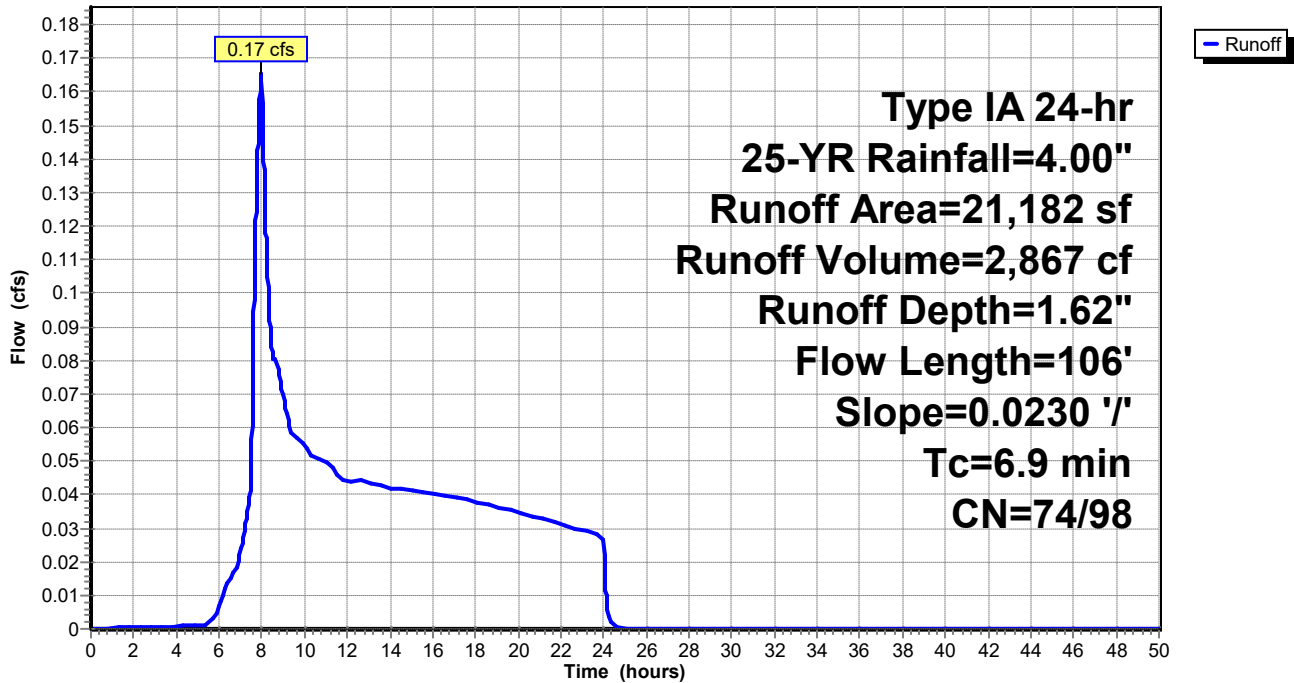

0780-003 HydroCAD Detention & WQ

Type IA 24-hr 25-YR Rainfall=4.00"

Prepared by Emerio Design LLC

Printed 5/25/2021

HydroCAD® 10.00-24 s/n 04804 © 2018 HydroCAD Software Solutions LLC

Page 25

Summary for Subcatchment 200: Post-developed Onsite Detained

Runoff = 1.06 cfs @ 7.90 hrs, Volume= 15,374 cf, Depth= 3.18"

Runoff by SBUH method, Split Pervious/Imperv., Time Span= 0.00-50.00 hrs, dt= 0.01 hrs
 Type IA 24-hr 25-YR Rainfall=4.00"

	Area (sf)	CN	Description
*	30,242	98	Impervious
*	27,737	86	Pervious
	57,979	92	Weighted Average
	27,737	86	47.84% Pervious Area
	30,242	98	52.16% Impervious Area

Tc (min)	Length (feet)	Slope (ft/ft)	Velocity (ft/sec)	Capacity (cfs)	Description
5.0					Direct Entry,

Subcatchment 200: Post-developed Onsite Detained

Hydrograph

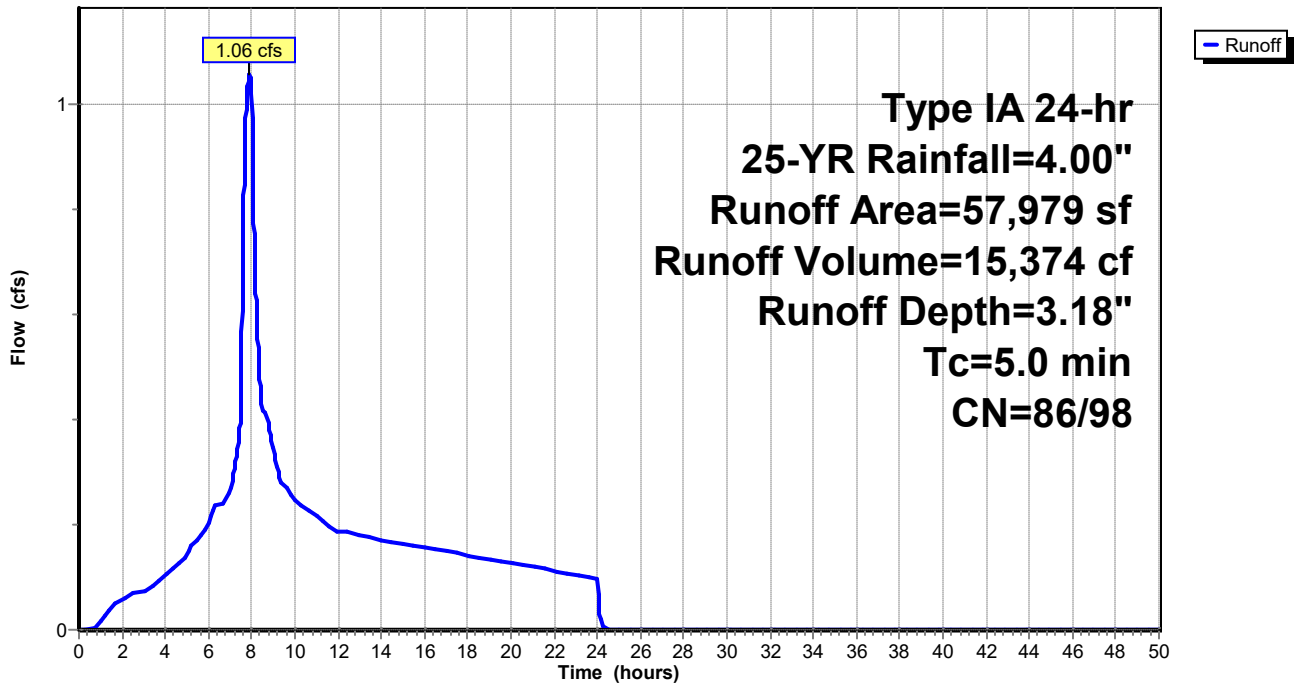

0780-003 HydroCAD Detention & WQ

Prepared by Emerio Design LLC

HydroCAD® 10.00-24 s/n 04804 © 2018 HydroCAD Software Solutions LLC

Type IA 24-hr 25-YR Rainfall=4.00"

Printed 5/25/2021

Page 26

Summary for Subcatchment 201: Undetained Development

Runoff = 0.41 cfs @ 7.89 hrs, Volume= 5,961 cf, Depth= 3.38"

Runoff by SBUH method, Split Pervious/Imperv., Time Span= 0.00-50.00 hrs, dt= 0.01 hrs
Type IA 24-hr 25-YR Rainfall=4.00"

	Area (sf)	CN	Description
*	14,434	98	Impervious
*	6,748	86	Pervious
	21,182	94	Weighted Average
	6,748	86	31.86% Pervious Area
	14,434	98	68.14% Impervious Area

Tc (min)	Length (feet)	Slope (ft/ft)	Velocity (ft/sec)	Capacity (cfs)	Description
5.0					Direct Entry,

Subcatchment 201: Undetained Development

Hydrograph

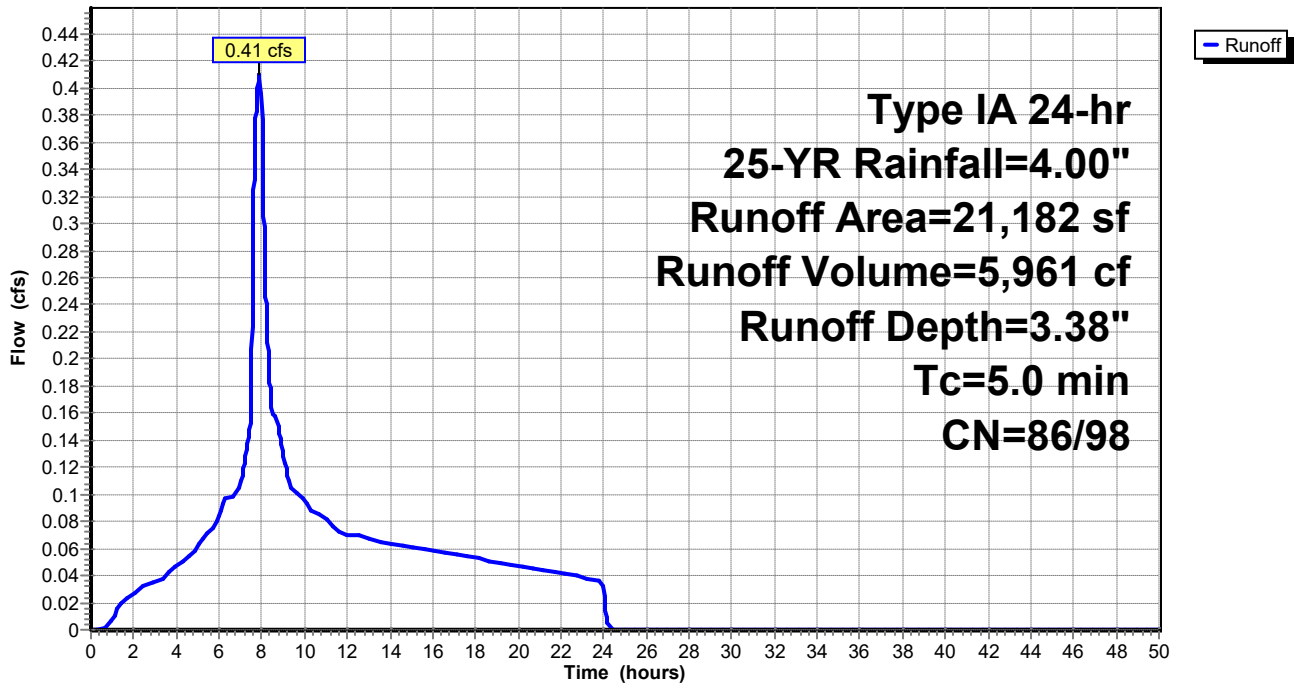

0780-003 HydroCAD Detention & WQ

Type IA 24-hr 25-YR Rainfall=4.00"

Prepared by Emerio Design LLC

Printed 5/25/2021

HydroCAD® 10.00-24 s/n 04804 © 2018 HydroCAD Software Solutions LLC

Page 27

Summary for Subcatchment 201a: Upstream

Runoff = 1.75 cfs @ 7.91 hrs, Volume= 25,433 cf, Depth= 3.04"

Runoff by SBUH method, Split Pervious/Imperv., Time Span= 0.00-50.00 hrs, dt= 0.01 hrs
Type IA 24-hr 25-YR Rainfall=4.00"

	Area (sf)	CN	Description
*	40,551	98	Impervious
*	59,896	86	Pervious
	100,447	91	Weighted Average
	59,896	86	59.63% Pervious Area
	40,551	98	40.37% Impervious Area

Tc (min)	Length (feet)	Slope (ft/ft)	Velocity (ft/sec)	Capacity (cfs)	Description
5.0					Direct Entry,

Subcatchment 201a: Upstream

Hydrograph

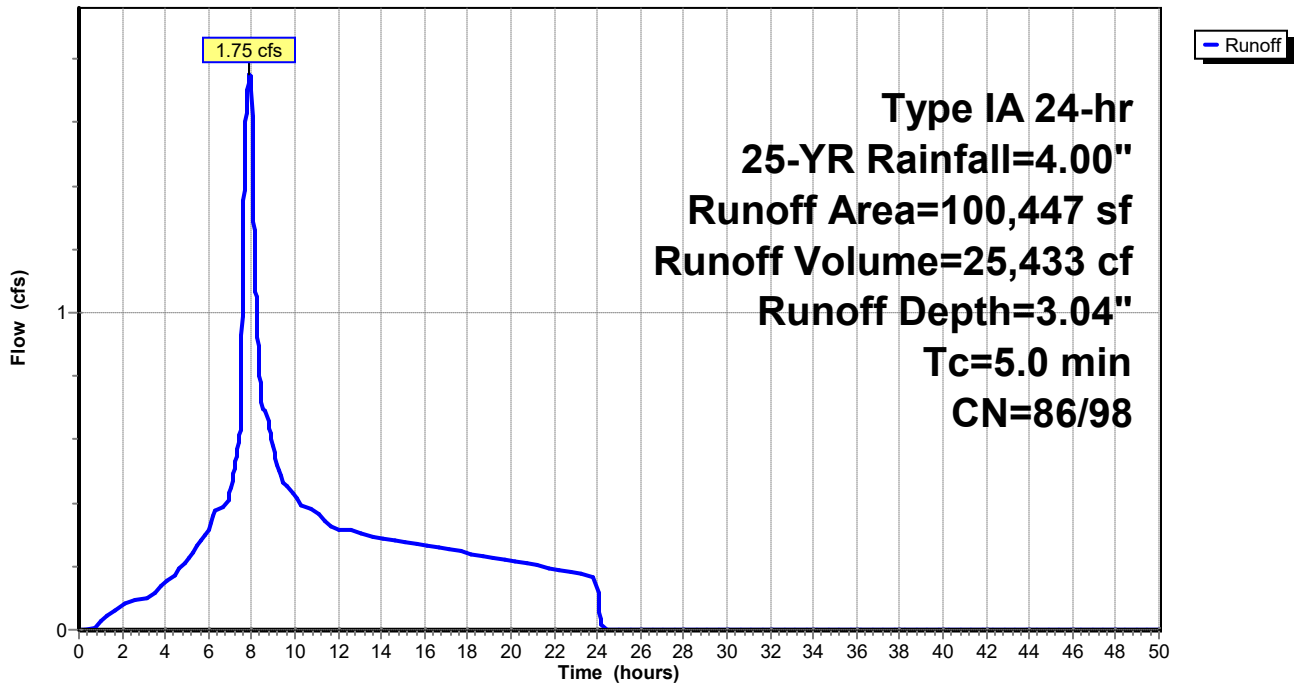

0780-003 HydroCAD Detention & WQ

Type IA 24-hr 25-YR Rainfall=4.00"

Prepared by Emerio Design LLC

Printed 5/25/2021

HydroCAD® 10.00-24 s/n 04804 © 2018 HydroCAD Software Solutions LLC

Page 28

Summary for Subcatchment 201b: Upstream

Runoff = 1.75 cfs @ 7.91 hrs, Volume= 25,433 cf, Depth= 3.04"

Runoff by SBUH method, Split Pervious/Imperv., Time Span= 0.00-50.00 hrs, dt= 0.01 hrs
Type IA 24-hr 25-YR Rainfall=4.00"

	Area (sf)	CN	Description
*	40,551	98	Impervious
*	59,896	86	Pervious
	100,447	91	Weighted Average
	59,896	86	59.63% Pervious Area
	40,551	98	40.37% Impervious Area

Tc (min)	Length (feet)	Slope (ft/ft)	Velocity (ft/sec)	Capacity (cfs)	Description
5.0					Direct Entry,

Subcatchment 201b: Upstream

Hydrograph

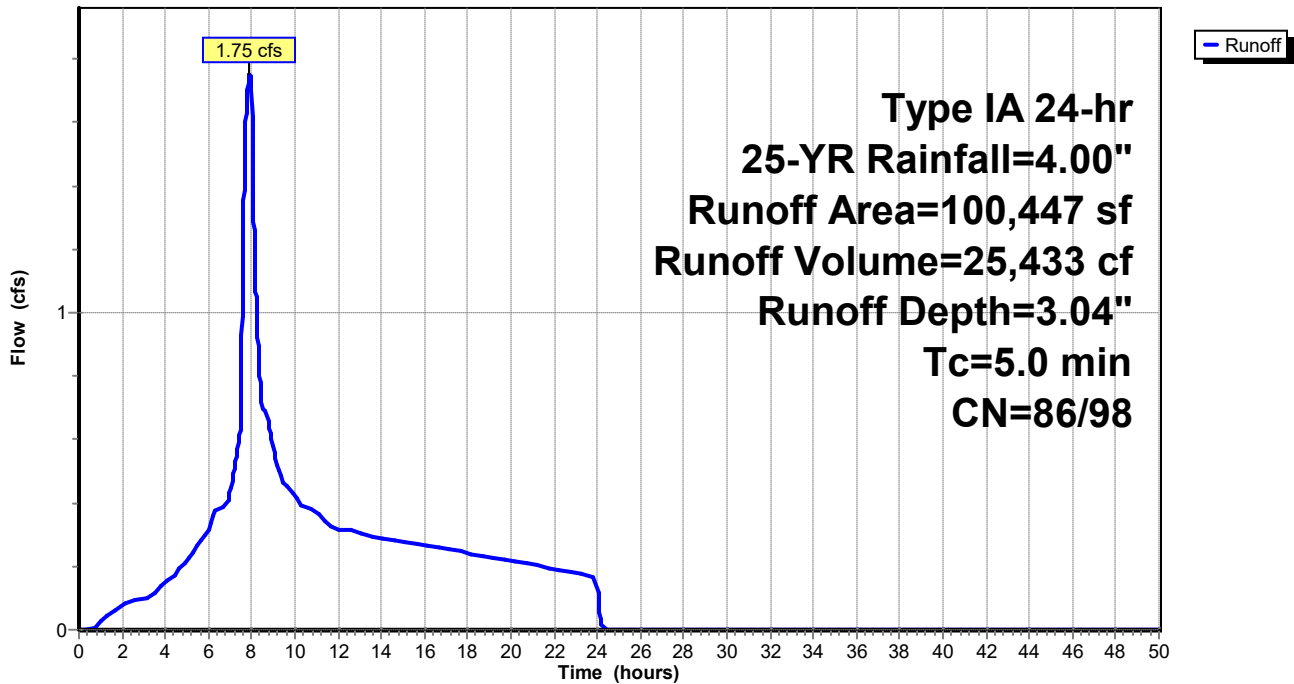

0780-003 HydroCAD Detention & WQ

Type IA 24-hr 25-YR Rainfall=4.00"

Prepared by Emerio Design LLC

Printed 5/25/2021

HydroCAD® 10.00-24 s/n 04804 © 2018 HydroCAD Software Solutions LLC

Page 29

Summary for Pond P1: Onsite Pond

Inflow Area = 158,426 sf, 44.69% Impervious, Inflow Depth = 3.09" for 25-YR event
 Inflow = 2.81 cfs @ 7.90 hrs, Volume= 40,807 cf
 Outflow = 1.56 cfs @ 8.24 hrs, Volume= 40,807 cf, Atten= 44%, Lag= 20.2 min
 Primary = 1.56 cfs @ 8.24 hrs, Volume= 40,807 cf

Routing by Stor-Ind method, Time Span= 0.00-50.00 hrs, dt= 0.01 hrs
 Peak Elev= 202.98' @ 8.24 hrs Surf.Area= 1,684 sf Storage= 4,916 cf

Plug-Flow detention time= 47.7 min calculated for 40,799 cf (100% of inflow)
 Center-of-Mass det. time= 47.8 min (752.7 - 705.0)

Volume	Invert	Avail.Storage	Storage Description
#1	199.70'	6,697 cf	Custom Stage Data (Prismatic) Listed below (Recalc)
Elevation (feet)	Surf.Area (sq-ft)	Inc.Store (cubic-feet)	Cum.Store (cubic-feet)
199.70	1,301	0	0
200.00	1,339	396	396
201.00	1,462	1,401	1,797
202.00	1,577	1,520	3,316
203.00	1,686	1,632	4,948
203.50	1,750	859	5,807
204.00	1,813	891	6,697

Device	Routing	Invert	Outlet Devices
#1	Primary	197.70'	12.0" Round Outlet Pipe L= 40.0' CMP, square edge headwall, Ke= 0.500 Inlet / Outlet Invert= 197.70' / 197.50' S= 0.0050 '/' Cc= 0.900 n= 0.013, Flow Area= 0.79 sf
#2	Device 1	198.00'	3.3" Vert. Low Orifice C= 0.620
#3	Device 2	200.05'	24.0" x 24.0" Horiz. Low Grate Inlet C= 0.620 Limited to weir flow at low heads
#4	Device 1	201.85'	5.7" Vert. High Orifice C= 0.620
#5	Device 1	199.70'	2.000 in/hr Growing Media Infiltration over Surface area above 197.70' Excluded Surface area = 0 sf

Primary OutFlow Max=1.56 cfs @ 8.24 hrs HW=202.98' (Free Discharge)

- 1=Outlet Pipe (Passes 1.56 cfs of 8.04 cfs potential flow)
- 2=Low Orifice (Orifice Controls 0.65 cfs @ 10.95 fps)
- 3=Low Grate Inlet (Passes 0.65 cfs of 34.08 cfs potential flow)
- 4=High Orifice (Orifice Controls 0.83 cfs @ 4.70 fps)
- 5=Growing Media Infiltration (Exfiltration Controls 0.08 cfs)

Pond P1: Onsite Pond

Hydrograph

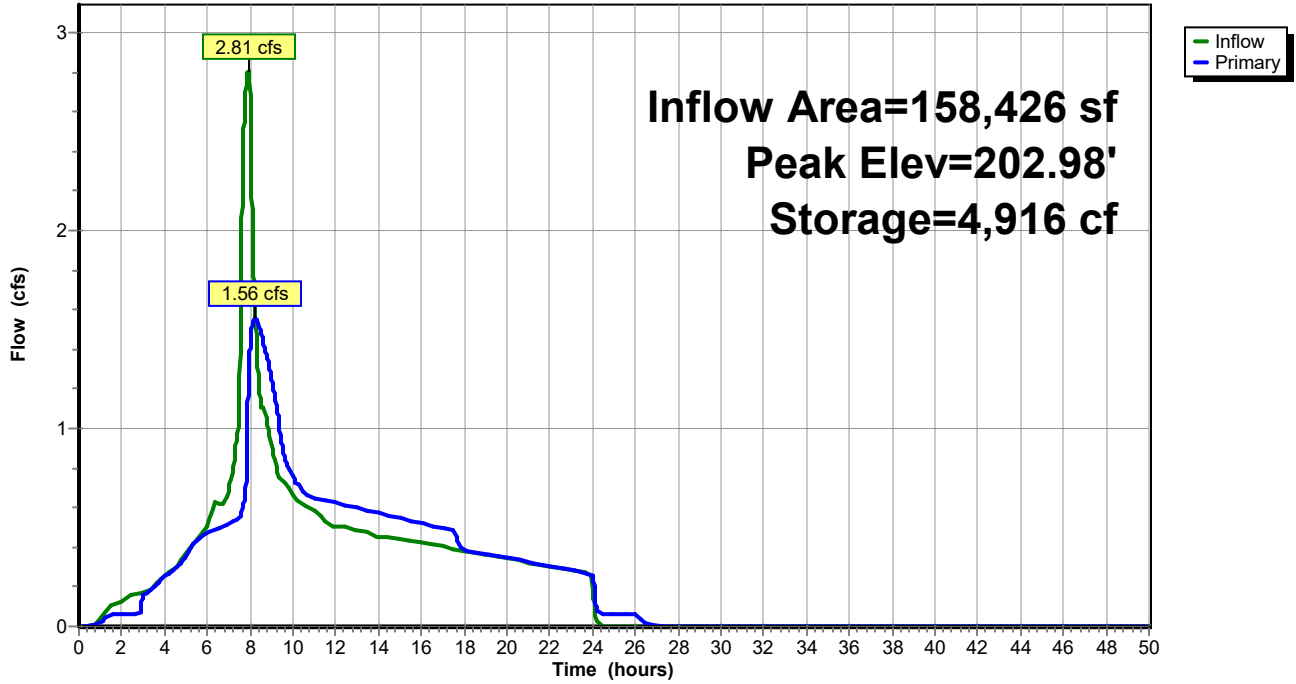

Summary for Link L1: Pre-Developed and Offsite Flows

Inflow Area = 179,608 sf, 22.73% Impervious, Inflow Depth = 2.41" for 25-YR event
Inflow = 2.32 cfs @ 7.95 hrs, Volume= 36,012 cf
Primary = 2.32 cfs @ 7.95 hrs, Volume= 36,012 cf, Atten= 0%, Lag= 0.0 min

Primary outflow = Inflow, Time Span= 0.00-50.00 hrs, dt= 0.01 hrs

Link L1: Pre-Developed and Offsite Flows

Hydrograph

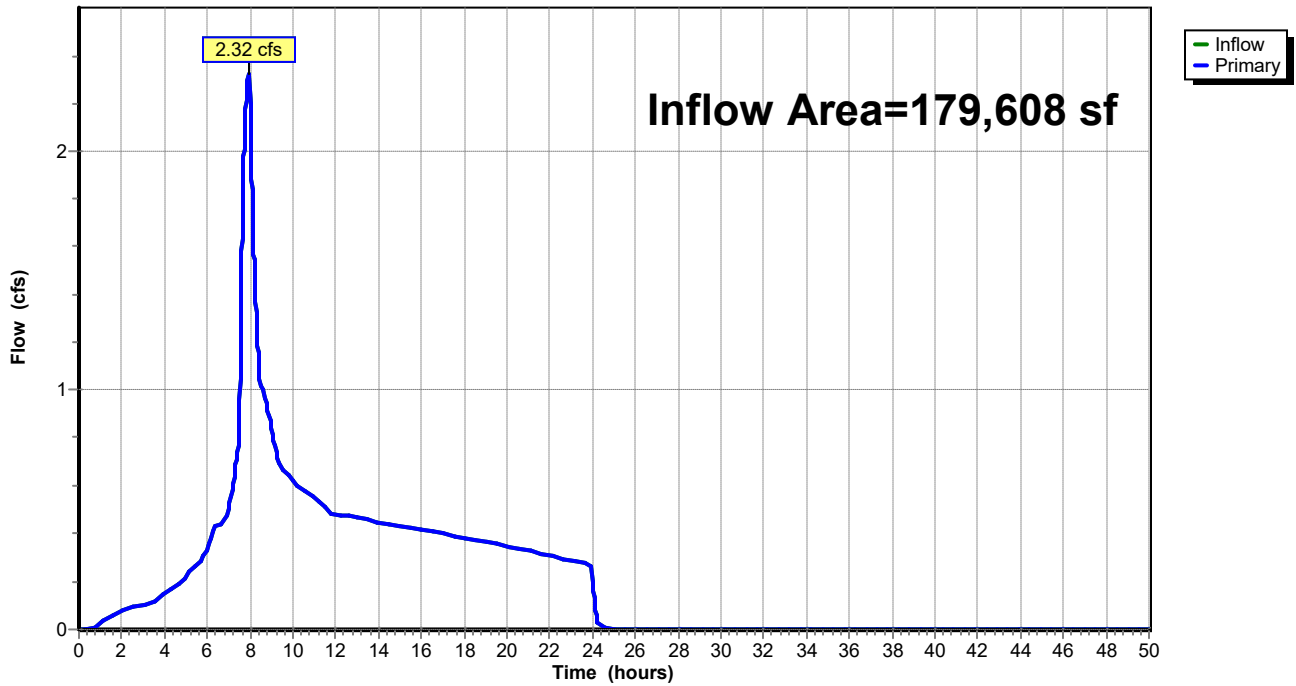

Summary for Link L2: Post-Developed and Offsite Flows

Inflow Area = 179,608 sf, 47.45% Impervious, Inflow Depth = 3.12" for 25-YR event
Inflow = 1.82 cfs @ 8.07 hrs, Volume= 46,768 cf
Primary = 1.82 cfs @ 8.07 hrs, Volume= 46,768 cf, Atten= 0%, Lag= 0.0 min

Primary outflow = Inflow, Time Span= 0.00-50.00 hrs, dt= 0.01 hrs

Link L2: Post-Developed and Offsite Flows

Hydrograph

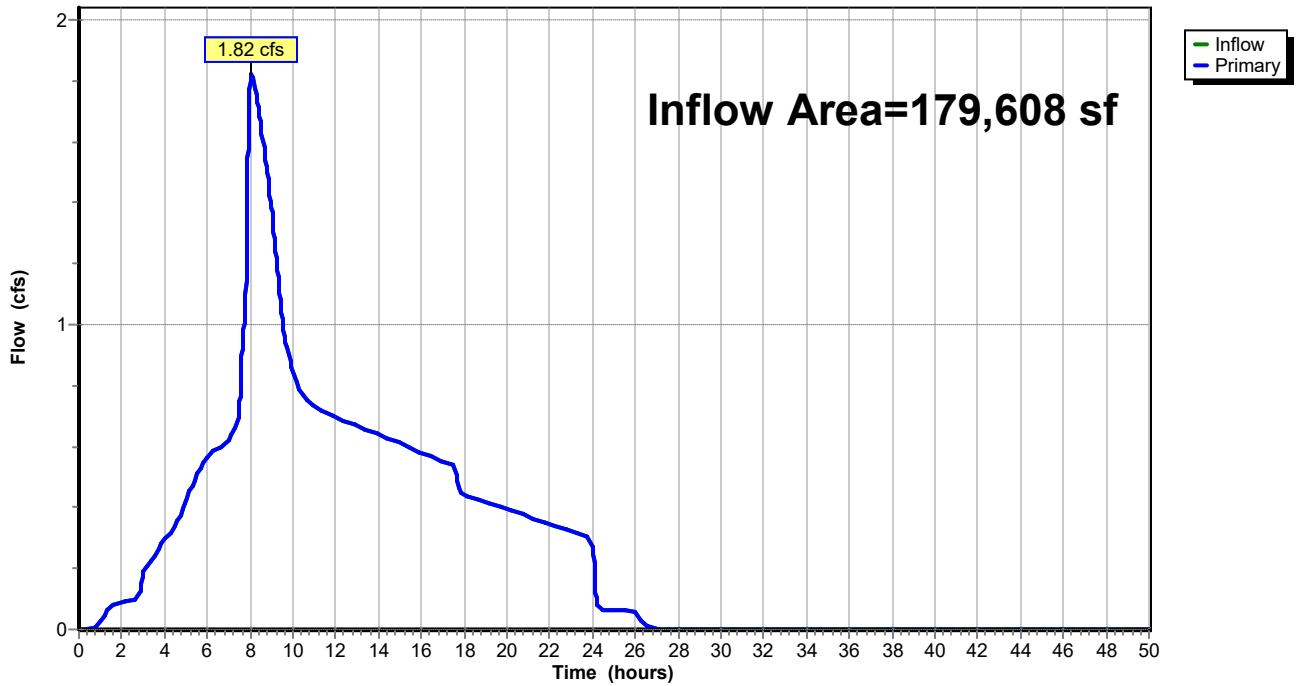

	Project:	Myrtlewood Subdivision Bypass Analysis													
	Project:	Conveyance Calculations													
	Date:	8/24/2021													
	Calc'd By:	Evans													
									Pipe Information and Calculations						
Segment	Design Section	Q (Calc'd) "Q"	Pipe Dia. (inch) "D"	Pipe Dia. (ft) "D"	Manning's number "n"	Slope "S" %	Slope "S"	Area Full (Calc'd) "Af"	Wetted Perimeter (Calc'd) "WPF"	Hydraulic Radius (Calc'd) "Rf"	Velocity Full (Calc'd) "Vf"	Flow Rate Full (Calc'd) "Qf"	% Pipe Capacity Used (Calc'd) "Q/Qf"		
Bypass Pipes #1-3	Onsite	70.30	42	3.50	0.013	0.56	0.0056	9.621	10.996	0.875	7.846	75.492	93.1%		
Bypass Pipe #4	Onsite	77.90	42	3.50	0.013	0.60	0.0060	9.621	10.996	0.875	8.122	78.142	99.7%		
Bypass Culverts #1-3	Crater Lane	25.97	27	2.25	0.013	0.87	0.0087	3.976	7.069	0.563	7.285	28.965	89.6%		

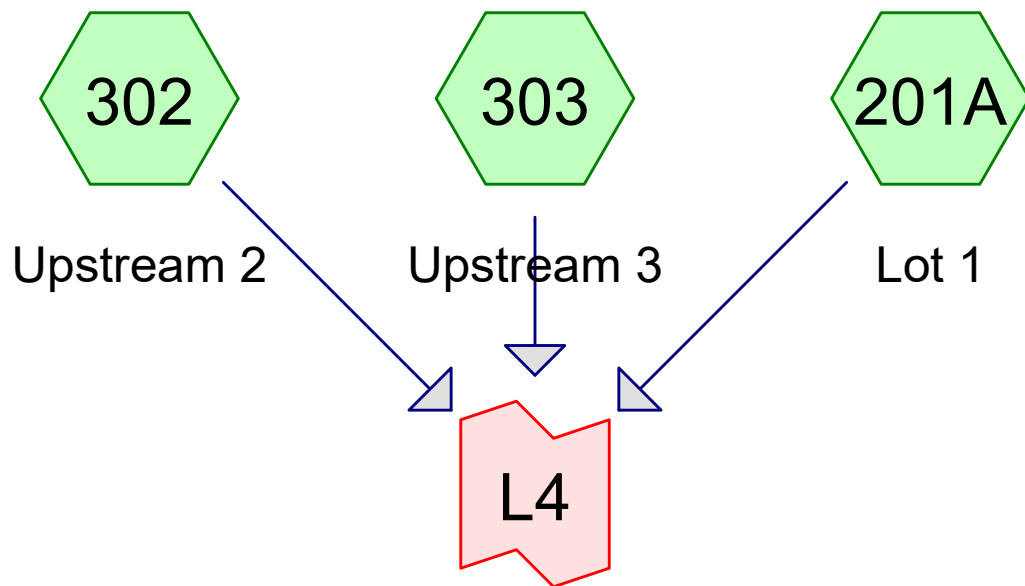

Triple Culvert Bypass

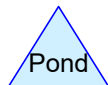
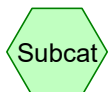

0780-003 Conveyance Check

Prepared by Emerio Design LLC

HydroCAD® 10.00-24 s/n 04804 © 2018 HydroCAD Software Solutions LLC

Printed 8/24/2021

Page 2

Area Listing (selected nodes)

Area (sq-ft)	CN	Description (subcatchment-numbers)
2,264,160	98	Impervious (201A, 302, 303)
3,625,487	86	Pervious (302, 303)
5,889,647	91	TOTAL AREA

0780-003 Conveyance Check

Prepared by Emerio Design LLC

HydroCAD® 10.00-24 s/n 04804 © 2018 HydroCAD Software Solutions LLC

Type IA 24-hr 25-YR Rainfall=4.00"

Printed 8/24/2021

Page 3

Summary for Subcatchment 201A: Lot 1

Runoff = 0.06 cfs @ 7.88 hrs, Volume= 903 cf, Depth= 3.77"

Runoff by SBUH method, Split Pervious/Imperv., Time Span= 0.00-50.00 hrs, dt= 0.01 hrs
Type IA 24-hr 25-YR Rainfall=4.00"

Area (sf)	CN	Description
* 2,877	98	Impervious
2,877	98	100.00% Impervious Area

Tc (min)	Length (feet)	Slope (ft/ft)	Velocity (ft/sec)	Capacity (cfs)	Description
5.0					Direct Entry,

Subcatchment 201A: Lot 1

Hydrograph

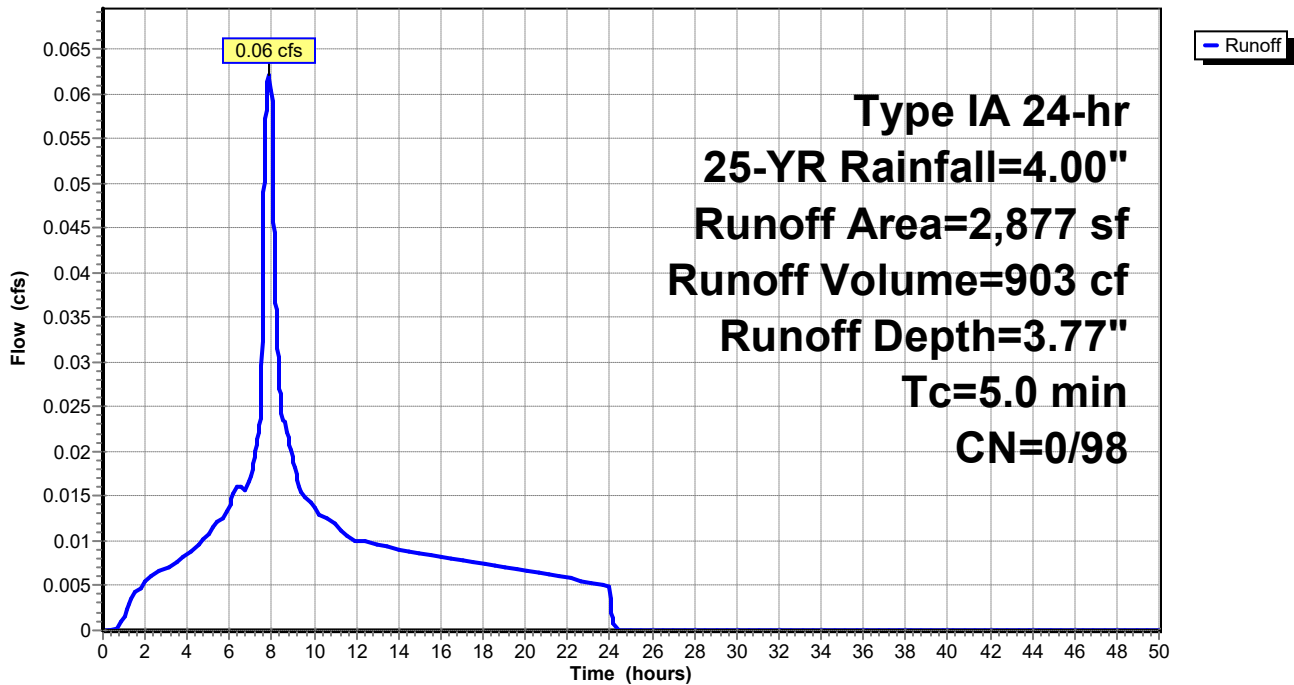

0780-003 Conveyance Check

Prepared by Emerio Design LLC

HydroCAD® 10.00-24 s/n 04804 © 2018 HydroCAD Software Solutions LLC

Type IA 24-hr 25-YR Rainfall=4.00"

Printed 8/24/2021

Page 4

Summary for Subcatchment 302: Upstream 2

Runoff = 7.69 cfs @ 7.94 hrs, Volume= 113,829 cf, Depth= 3.18"

Runoff by SBUH method, Split Pervious/Imperv., Time Span= 0.00-50.00 hrs, dt= 0.01 hrs
Type IA 24-hr 25-YR Rainfall=4.00"

	Area (sf)	CN	Description
*	223,598	98	Impervious
*	205,821	86	Pervious
	429,419	92	Weighted Average
	205,821	86	47.93% Pervious Area
	223,598	98	52.07% Impervious Area

Tc (min)	Length (feet)	Slope (ft/ft)	Velocity (ft/sec)	Capacity (cfs)	Description
1.4	100	0.0206	1.23		Sheet Flow, Smooth surfaces n= 0.011 P2= 2.50"
0.8	143	0.0206	2.91		Shallow Concentrated Flow, Paved Kv= 20.3 fps
0.1	57	0.0200	6.42	5.04	Pipe Channel, 12.0" Round Area= 0.8 sf Perim= 3.1' r= 0.25' n= 0.013
0.7	217	0.0140	5.37	4.22	Pipe Channel, 12.0" Round Area= 0.8 sf Perim= 3.1' r= 0.25' n= 0.013
3.0	382	0.0022	2.13	1.67	Pipe Channel, 12.0" Round Area= 0.8 sf Perim= 3.1' r= 0.25' n= 0.013
0.3	54	0.0050	3.21	2.52	Pipe Channel, 12.0" Round Area= 0.8 sf Perim= 3.1' r= 0.25' n= 0.013
0.1	28	0.0050	3.72	4.57	Pipe Channel, 15.0" Round Area= 1.2 sf Perim= 3.9' r= 0.31' n= 0.013
0.6	132	0.0050	3.72	4.57	Pipe Channel, 15.0" Round Area= 1.2 sf Perim= 3.9' r= 0.31' n= 0.013
7.0	1,113	Total			

0780-003 Conveyance Check

Prepared by Emerio Design LLC

HydroCAD® 10.00-24 s/n 04804 © 2018 HydroCAD Software Solutions LLC

Type IA 24-hr 25-YR Rainfall=4.00"

Printed 8/24/2021

Page 5

Subcatchment 302: Upstream 2

Hydrograph

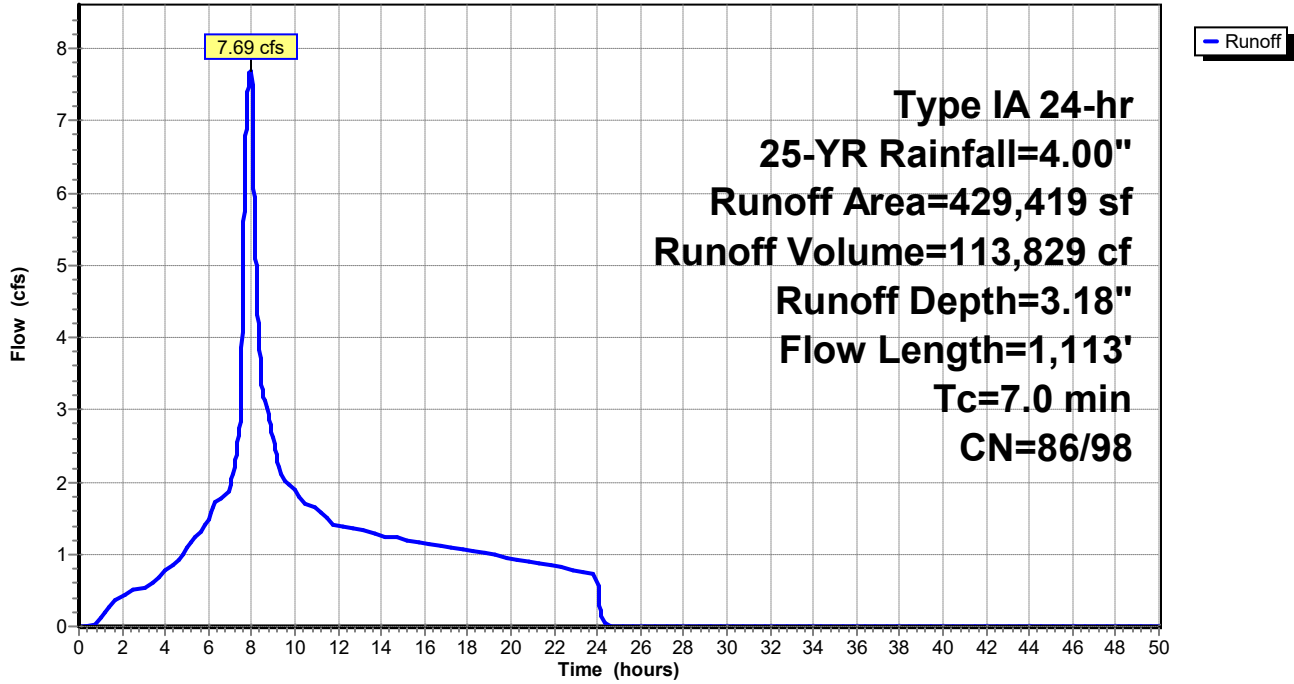

0780-003 Conveyance Check

Type IA 24-hr 25-YR Rainfall=4.00"

Prepared by Emerio Design LLC

Printed 8/24/2021

HydroCAD® 10.00-24 s/n 04804 © 2018 HydroCAD Software Solutions LLC

Page 6

Summary for Subcatchment 303: Upstream 3

Runoff = 70.30 cfs @ 8.01 hrs, Volume= 1,364,968 cf, Depth= 3.00"

Runoff by SBUH method, Split Pervious/Imperv., Time Span= 0.00-50.00 hrs, dt= 0.01 hrs
Type IA 24-hr 25-YR Rainfall=4.00"

	Area (sf)	CN	Description
*	2,037,685	98	Impervious
*	3,419,666	86	Pervious
	5,457,351	90	Weighted Average
	3,419,666	86	62.66% Pervious Area
	2,037,685	98	37.34% Impervious Area

0780-003 Conveyance Check

Prepared by Emerio Design LLC

HydroCAD® 10.00-24 s/n 04804 © 2018 HydroCAD Software Solutions LLC

Type IA 24-hr 25-YR Rainfall=4.00"

Printed 8/24/2021

Page 7

Tc (min)	Length (feet)	Slope (ft/ft)	Velocity (ft/sec)	Capacity (cfs)	Description
4.7	100	0.1710	0.35		Sheet Flow, Grass: Short n= 0.150 P2= 2.50"
6.0	1,035	0.1710	2.89		Shallow Concentrated Flow, Short Grass Pasture Kv= 7.0 fps
8.8	2,328	0.0468	4.39		Shallow Concentrated Flow, Paved Kv= 20.3 fps
0.6	359	0.0307	10.42	18.41	Pipe Channel, 18.0" Round Area= 1.8 sf Perim= 4.7' r= 0.38' n= 0.013
0.1	35	0.0089	4.97	6.09	Pipe Channel, 15.0" Round Area= 1.2 sf Perim= 3.9' r= 0.31' n= 0.013
0.1	28	0.0152	6.78	9.46	Pipe Channel, 16.0" Round Area= 1.4 sf Perim= 4.2' r= 0.33' n= 0.013
0.2	61	0.0152	6.78	9.46	Pipe Channel, 16.0" Round Area= 1.4 sf Perim= 4.2' r= 0.33' n= 0.013
0.5	239	0.0150	7.28	12.87	Pipe Channel, 18.0" Round Area= 1.8 sf Perim= 4.7' r= 0.38' n= 0.013
0.2	114	0.0150	9.54	37.93	Pipe Channel, 27.0" Round Area= 4.0 sf Perim= 7.1' r= 0.56' n= 0.013
0.6	323	0.0150	8.82	27.71	Pipe Channel, 24.0" Round Area= 3.1 sf Perim= 6.3' r= 0.50' n= 0.013
0.2	129	0.0150	8.82	27.71	Pipe Channel, 24.0" Round Area= 3.1 sf Perim= 6.3' r= 0.50' n= 0.013
0.4	159	0.0080	6.97	27.70	Pipe Channel, 27.0" Round Area= 4.0 sf Perim= 7.1' r= 0.56' n= 0.013
0.3	139	0.0100	8.36	41.02	Pipe Channel, 30.0" Round Area= 4.9 sf Perim= 7.9' r= 0.63' n= 0.013
0.1	63	0.0100	8.36	41.02	Pipe Channel, 30.0" Round Area= 4.9 sf Perim= 7.9' r= 0.63' n= 0.013
0.3	118	0.0100	7.79	30.97	Pipe Channel, 27.0" Round Area= 4.0 sf Perim= 7.1' r= 0.56' n= 0.013
0.3	134	0.0100	7.79	30.97	Pipe Channel, 27.0" Round Area= 4.0 sf Perim= 7.1' r= 0.56' n= 0.013
0.4	199	0.0100	8.36	41.02	Pipe Channel, 30.0" Round Area= 4.9 sf Perim= 7.9' r= 0.63' n= 0.013
0.3	133	0.0100	8.36	41.02	Pipe Channel, 30.0" Round Area= 4.9 sf Perim= 7.9' r= 0.63'

0780-003 Conveyance Check

Prepared by Emerio Design LLC

HydroCAD® 10.00-24 s/n 04804 © 2018 HydroCAD Software Solutions LLC

Type IA 24-hr 25-YR Rainfall=4.00"

Printed 8/24/2021

Page 8

n= 0.013

0.2	128	0.0239	12.92	63.41	Pipe Channel, 30.0" Round Area= 4.9 sf Perim= 7.9' r= 0.63' n= 0.013
0.6	205	0.0050	5.91	29.00	Pipe Channel, 30.0" Round Area= 4.9 sf Perim= 7.9' r= 0.63' n= 0.013
0.3	164	0.0128	9.45	46.41	Pipe Channel, 30.0" Round Area= 4.9 sf Perim= 7.9' r= 0.63' n= 0.013
0.7	297	0.0081	7.52	36.92	Pipe Channel, 30.0" Round Area= 4.9 sf Perim= 7.9' r= 0.63' n= 0.013
0.3	132	0.0086	7.75	38.04	Pipe Channel, 30.0" Round Area= 4.9 sf Perim= 7.9' r= 0.63' n= 0.013
0.4	222	0.0083	8.60	60.77	Pipe Channel, 36.0" Round Area= 7.1 sf Perim= 9.4' r= 0.75' n= 0.013
0.5	243	0.0078	8.33	58.91	Pipe Channel, 36.0" Round Area= 7.1 sf Perim= 9.4' r= 0.75' n= 0.013

27.1 7,087 Total

Subcatchment 303: Upstream 3

Hydrograph

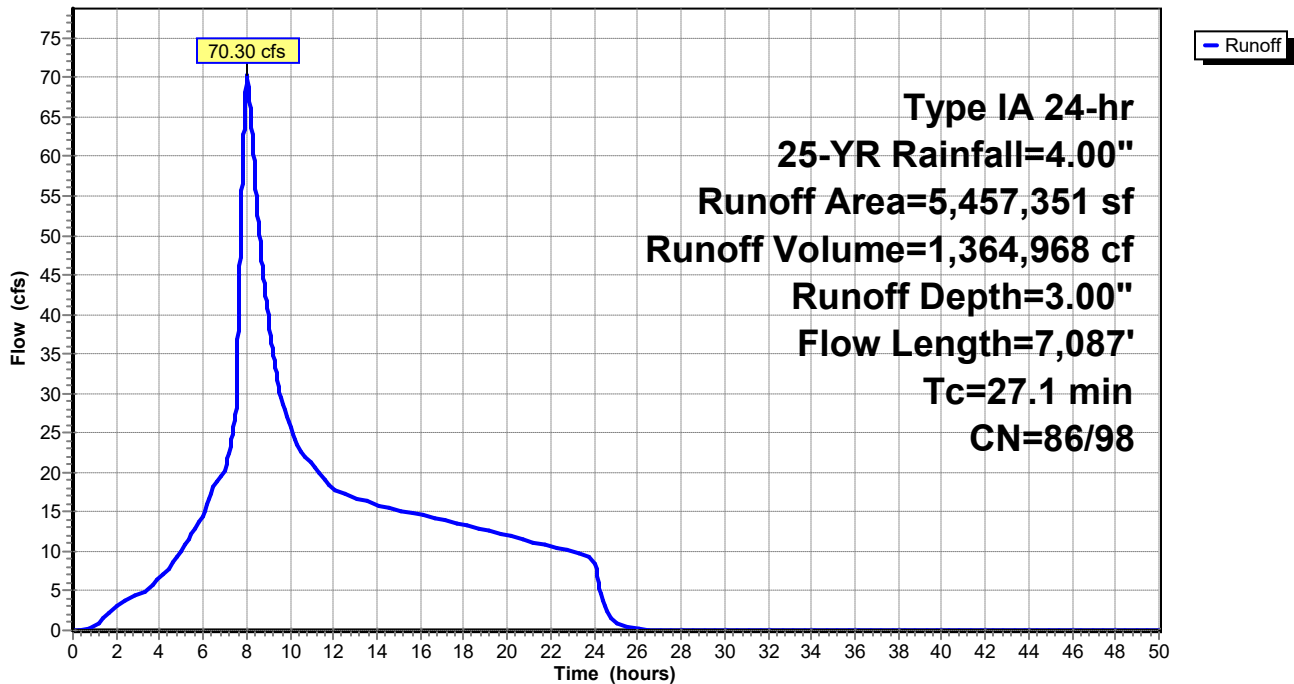

0780-003 Conveyance Check

Prepared by Emerio Design LLC

HydroCAD® 10.00-24 s/n 04804 © 2018 HydroCAD Software Solutions LLC

Type IA 24-hr 25-YR Rainfall=4.00"

Printed 8/24/2021

Page 9

Summary for Link L4: Triple Culvert Bypass

Inflow Area = 5,889,647 sf, 38.44% Impervious, Inflow Depth = 3.01" for 25-YR event
Inflow = 77.90 cfs @ 8.01 hrs, Volume= 1,479,701 cf
Primary = 77.90 cfs @ 8.01 hrs, Volume= 1,479,701 cf, Atten= 0%, Lag= 0.0 min

Primary outflow = Inflow, Time Span= 0.00-50.00 hrs, dt= 0.01 hrs

Link L4: Triple Culvert Bypass

Hydrograph

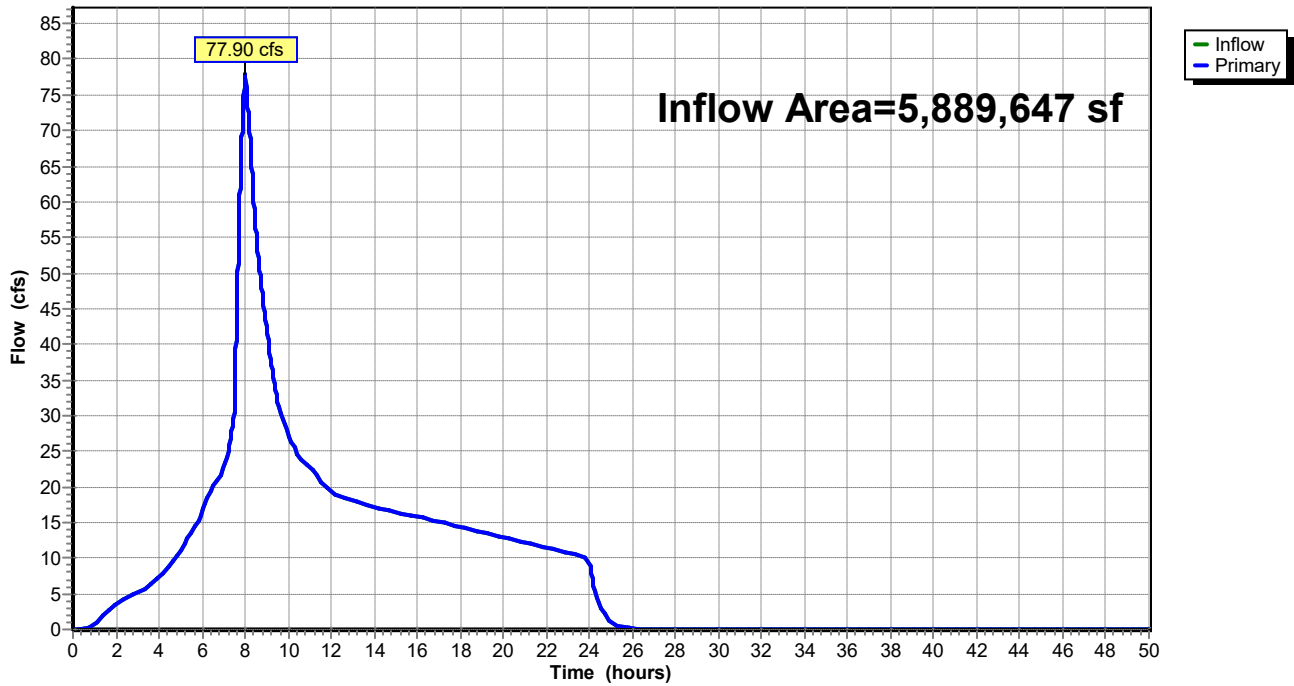

Appendix D:

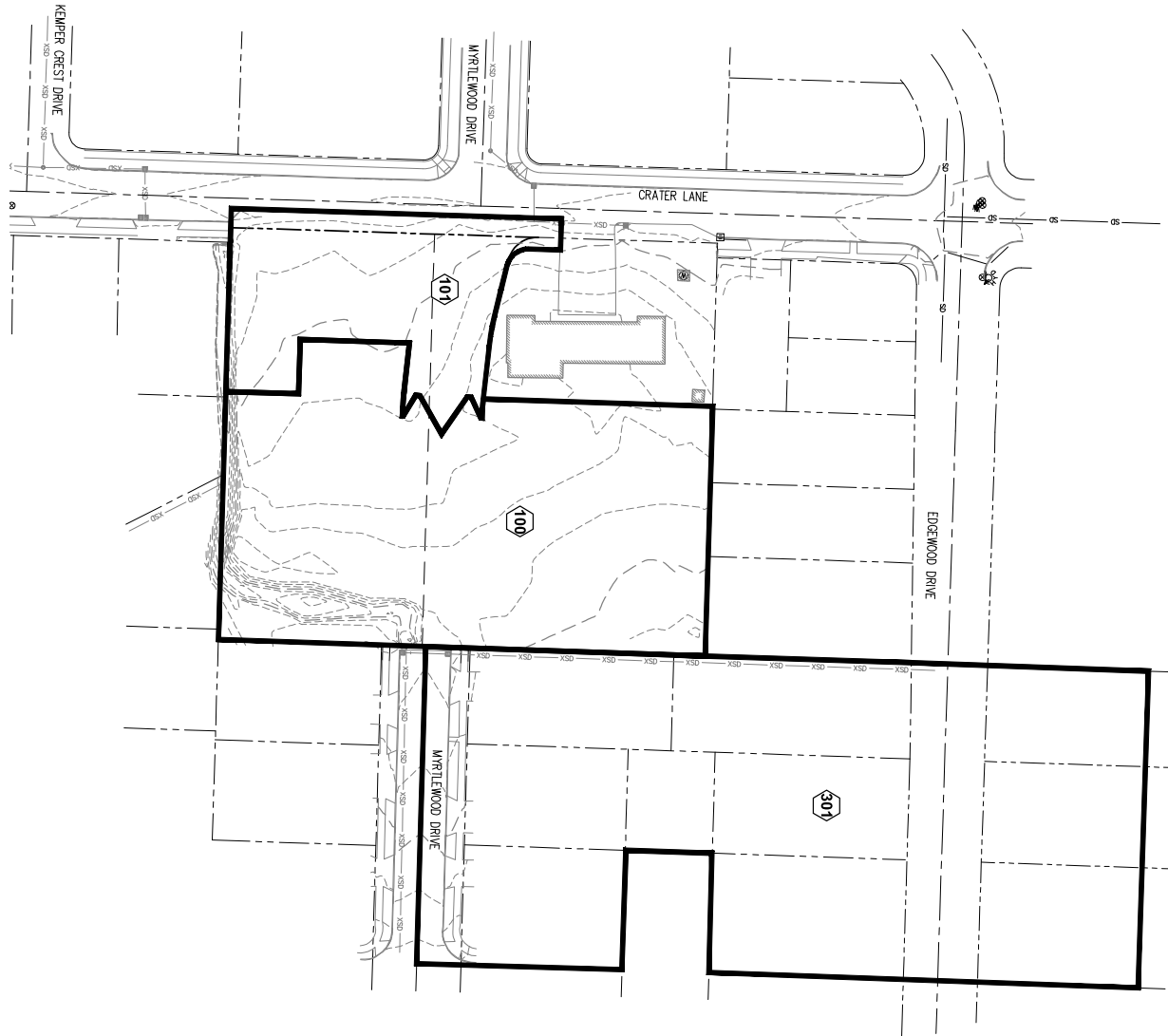

SHEET
1
3

EMERIO
ENGINEERING • SURVEYING • DESIGN

6445 SW FALLBROOK PLACE, SUITE 100
BEAVERTON, OREGON 97008
TEL: (503) 746-8812
FAX: (503) 834-8692
www.emeriodesign.com

REVISIONS	
NO.	DESCRIPTION

**PRE-DEVELOPED BASIN
MAP**

MYRTLEWOOD SUBDIVISION
A 10 LOT SUBDIVISION OF
ADJUSTED TAX LOT 3202
TAX MAP 3 2 07
CITY OF NEWBERG, OREGON

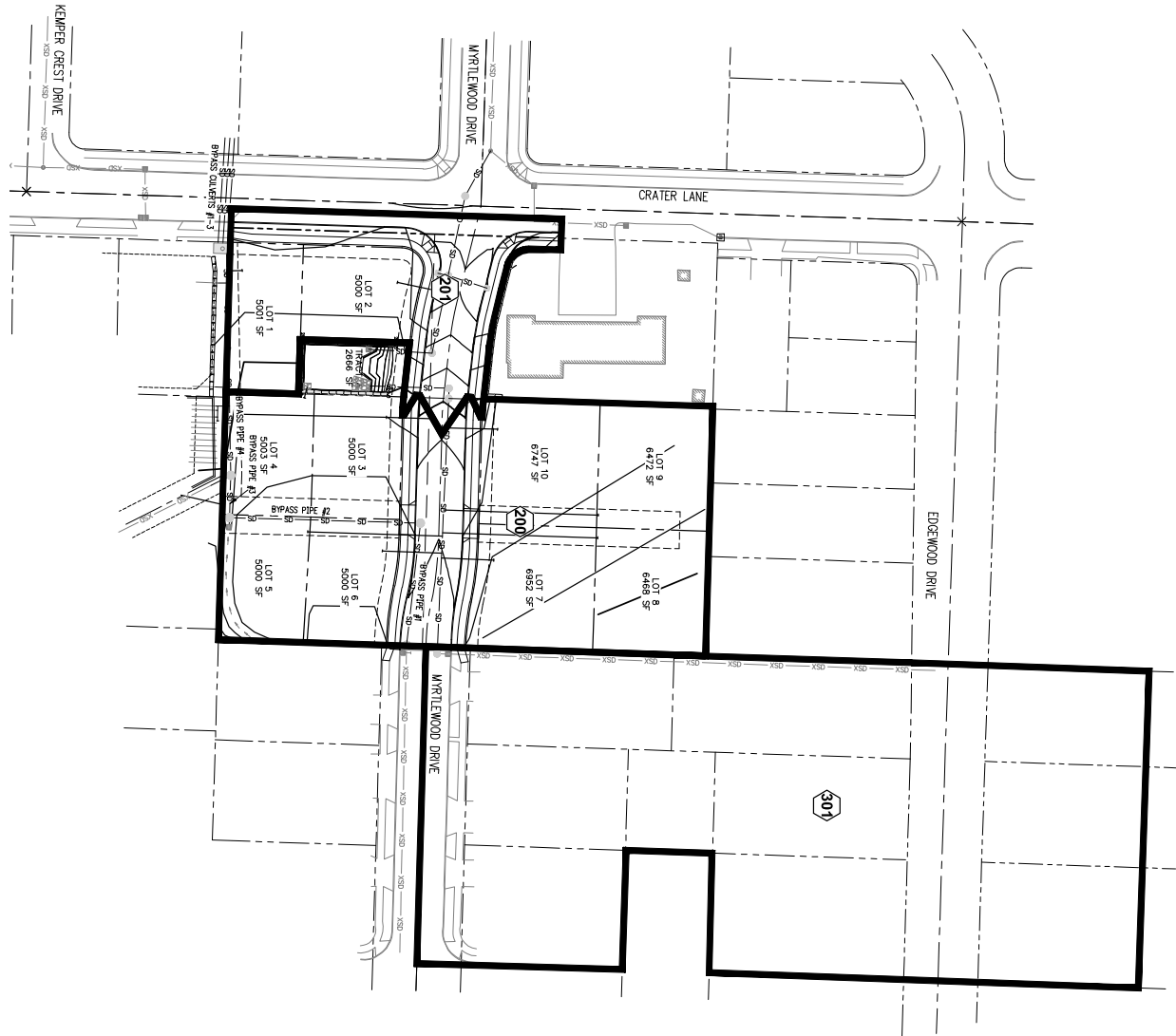

SHEET
2
3

EMERIO
ENGINEERING • SURVEYING • DESIGN

6445 SW FALLBROOK PLACE, SUITE 100
BEAVERTON, OREGON 97008
TEL: (503) 746-6812
FAX: (503) 638-6692
www.emeriodesign.com

REVISIONS		
NO.	DATE	DESCRIPTION

**POST-DEVELOPED
TREATMENT BASIN MAP**

MYRTLEWOOD SUBDIVISION
A 10 LOT SUBDIVISION OF
ADJUSTED TAX LOT 3202
TAX MAP 3 2 07
CITY OF NEWBERG, OREGON

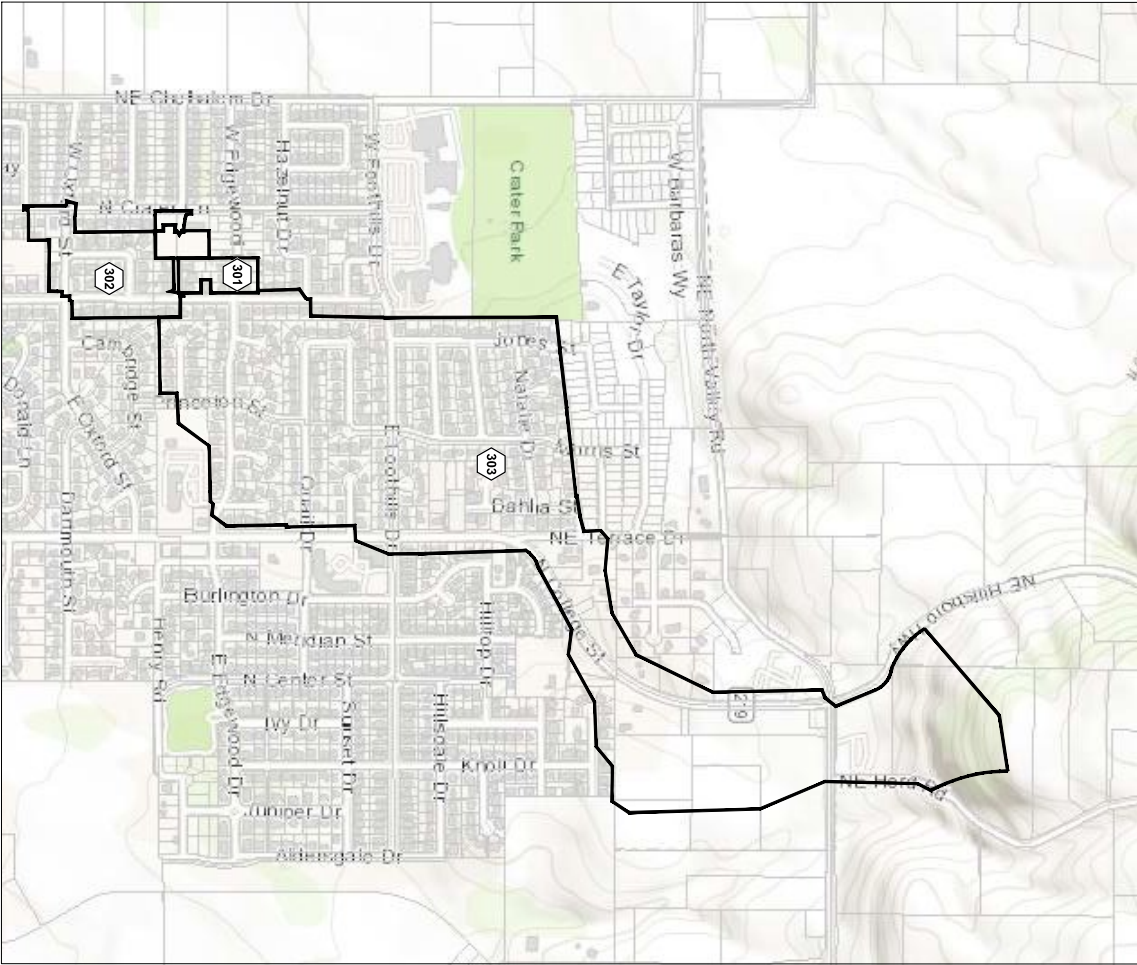

SHEET
3
OF
3

EMERIO
ENGINEERING • SURVEYING • DESIGN

6445 SW FALLBROOK PLACE, SUITE 100
BEAVERTON, OREGON 97008
TEL: (503) 746-8112
FAX: (503) 634-8992
www.emeriodesign.com

REVISIONS	
NO.	DATE

UPSTREAM BASIN MAP

MYRTLEWOOD SUBDIVISION
A 10 LOT SUBDIVISION OF
ADJUSTED TAX LOT 3202
TAX MAP 3 2 07
CITY OF NEWBERG, OREGON

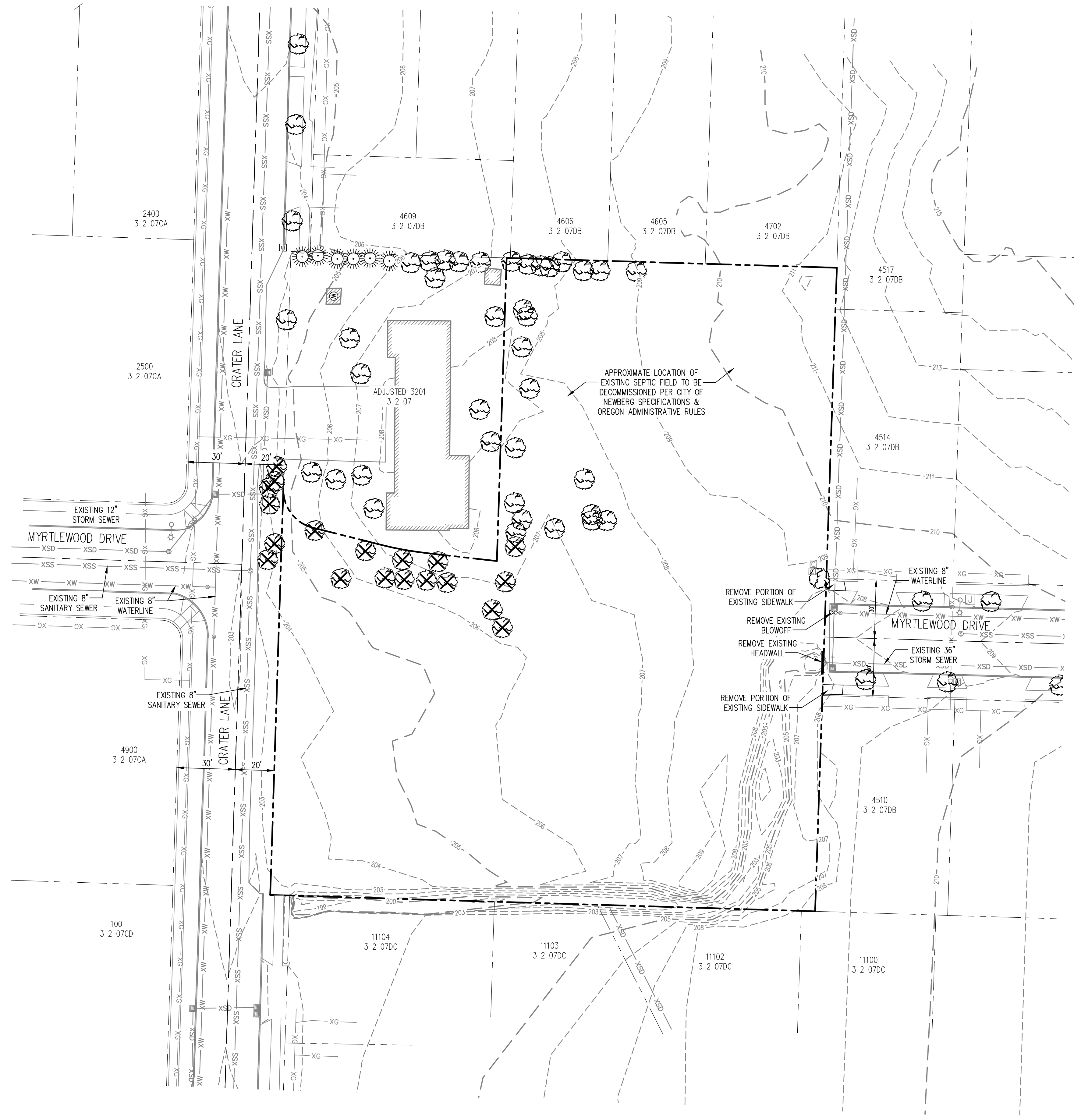
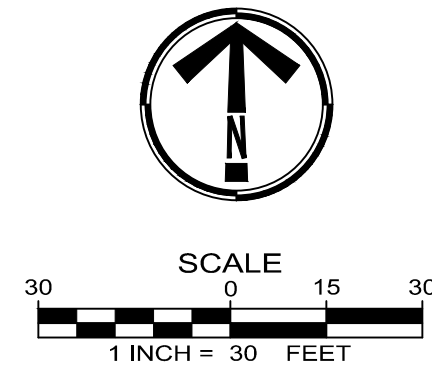

EXISTING CONDITIONS &
PRELIMINARY DEMOLITION PLAN
SCALE: 1" = 30'

MYRTLEWOOD SUBDIVISION
A 10 LOT SUBDIVISION OF
ADJUSTED TAX LOT 3202
TAX MAP 3 2 07
CITY OF NEWBERG, OREGON

PRELIMINARY PLAT
EXISTING CONDITIONS &
PRELIMINARY
DEMOLITION PLAN

NO.	DATE	DESCRIPTION

EMERIO
ENGINEERING • SURVEYING • DESIGN
6445 SW FALLBROOK PLACE, SUITE 100
BEAVERTON, OREGON 97008
TEL: (503) 746-9812
FAX: (503) 639-9892
www.emeriodesign.com



First American

First American Title Insurance Company

775 NE Evans Street
McMinnville, OR 97128
Phn - (503)376-7363
Fax - (866)800-7294

**PUBLIC RECORD REPORT
FOR NEW SUBDIVISION OR LAND PARTITION**

THIS REPORT IS ISSUED BY THE ABOVE-NAMED COMPANY ("THE COMPANY") FOR THE EXCLUSIVE USE OF:

Steve Edelman
16869 Southwest 65th Avenue, Suite 115
Lake Oswego, OR 97035
Phone: (503)473-8870
Fax: (503)473-8872

Date Prepared : August 18, 2021
Effective Date : 8:00 A.M on August 16, 2021
Order No. : 1039-3806661
Subdivision : **CRATER LANE PROJECT**

The information contained in this report is furnished by First American Title Insurance Company (the "Company") as an information service based on the records and indices maintained by the Company for the county identified below. This report is not title insurance, is not a preliminary title report for title insurance, and is not a commitment for title insurance. No examination has been made of the Company's records, other than as specifically set forth in this report. Liability for any loss arising from errors and/or omissions is limited to the lesser of the fee paid or the actual loss to the Customer, and the Company will have no greater liability by reason of this report. This report is subject to the Definitions, Conditions and Stipulations contained in it.

REPORT

- A. The Land referred to in this report is located in the County of Yamhill, State of Oregon, and is described as follows:

As fully set forth on Exhibit "A" attached hereto and by this reference made a part hereof.

- B. As of the Effective Date, the tax account and map references pertinent to the Land are as follows:

As fully set forth on Exhibit "A" attached hereto and by this reference made a part hereof.

- C. As of the Effective Date and according to the Public Records, we find title to the land apparently vested in:

As fully set forth on Exhibit "B" attached hereto and by this reference made a part hereof

- D. As of the Effective Date and according to the Public Records, the Land is subject to the following liens and encumbrances, which are not necessarily shown in the order of priority:

As fully set forth on Exhibit "C" attached hereto and by this reference made a part hereof.

EXHIBIT "A"
(Land Description Map Tax and Account)

A portion of that tract of land conveyed to Linda Jean Hamlett Living Trust by Deed recorded as Document No. 200917448, Yamhill County Deed Records, being situated in the Southeast Quarter of Section 7, Township 3 South, Range 2 West of the Willamette Meridian, City of Newberg, County of Yamhill, State of Oregon, being more particularly described as follows:

Beginning at the Southwest corner of said Hamlett tract being on the Easterly right of way line of Crater Lane (20.0 feet from centerline); thence along said Easterly right of way line, North 01°50'32" East, 208.50 feet; thence 27.15 feet on the arc of a nontangent 20.00 foot radius curve (the radius point bears South 88°09'28" East) through a central angle of 77°47'31": (the chord bears South 37°03'13" East, 25.12 feet); thence South 75°56'59" East, 36.76 feet to a point of curvature; thence 22.95 feet on the arc of a 173.00 foot radius curve to the left through a central angle of 07°36'05" (the chord bears South 79°45'01" East, 22.93 feet); thence South 83°33'03" East, 36.39 feet; thence North 01°50'32" East, 155.56 feet to the Northerly line of said Hamlett tract, also being the Southerly line of the Plat of EDGEWOOD ESTATES; thence along said Southerly plat line and its Easterly extension, South 88°17'44" East, 169.38 feet to the Northeast corner of said Hamlett tract on the Westerly line of the Plat of THE MEADOWS NO. 4; thence along said Westerly plat line, South 01°56'04" West, 330.26 feet to the Southeast corner of said Hamlett tract on the Northerly line of the Plat of COTTONWOOD MEADOWS NO. 2; thence along said Northerly plat line, North 88°16'45" West, 279.51 feet to the Point of Beginning.

Map No.: R3207 03202
Tax Account No.: 428451

EXHIBIT "B"
(Vesting)

Greenwing Restorations, LLC, an Oregon limited liability company

EXHIBIT "C"
(Liens and Encumbrances)

1. Taxes for the fiscal year 2021-2022 a lien due, but not yet payable.
2. City liens, if any, of the City of Newberg.
3. The rights of the public in and to that portion of the premises herein described lying within the limits of streets, roads and highways.
4. Line of Credit Trust Deed, including the terms and provisions thereof, given to secure an indebtedness of up to
Grantor: Greenwing Restorations, LLC, an Oregon limited liability company
Beneficiary: Transpacific dk Investments 1, LLC, an Oregon limited liability company
Trustee: WFG National Title Insurance Company
Dated: July 20, 2021
Recorded: July 21, 2021
Recording Information: Instrument No. 202115021, Deed and Mortgage Records
5. Any conveyance or encumbrance by Greenwing Restorations, LLC should be executed pursuant to their Operating Agreement , a copy of which should be submitted to this office for inspection.
6. Unrecorded leases or periodic tenancies, if any.

NOTE: Taxes for the year 2020-2021 PAID IN FULL

Tax Amount:	\$1,252.86
Map No.:	
Property ID:	428451
Tax Code No.:	29.0

DEFINITIONS, CONDITIONS AND STIPULATIONS

1. **Definitions.** The following terms have the stated meaning when used in this report:
 - (a) "Customer": The person or persons named or shown as the addressee of this report.
 - (b) "Effective Date": The effective date stated in this report.
 - (c) "Land": The land specifically described in this report and improvements affixed thereto which by law constitute real property.
 - (d) "Public Records": Those records which by the laws of the state of Oregon impart constructive notice of matters relating to the Land.

2. **Liability of the Company.**
 - (a) THIS REPORT IS NOT AN INSURED PRODUCT OR SERVICE OR A REPRESENTATION OF THE CONDITION OF TITLE TO REAL PROPERTY. IT IS NOT AN ABSTRACT, LEGAL OPINION, OPINION OF TITLE, TITLE INSURANCE COMMITMENT OR PRELIMINARY REPORT, OR ANY FORM OF TITLE INSURANCE OR GUARANTY. THIS REPORT IS ISSUED EXCLUSIVELY FOR THE BENEFIT OF THE APPLICANT THEREFOR, AND MAY NOT BE USED OR RELIED UPON BY ANY OTHER PERSON. THIS REPORT MAY NOT BE REPRODUCED IN ANY MANNER WITHOUT FIRST AMERICAN'S PRIOR WRITTEN CONSENT. FIRST AMERICAN DOES NOT REPRESENT OR WARRANT THAT THE INFORMATION HEREIN IS COMPLETE OR FREE FROM ERROR, AND THE INFORMATION HEREIN IS PROVIDED WITHOUT ANY WARRANTIES OF ANY KIND, AS-IS, AND WITH ALL FAULTS. AS A MATERIAL PART OF THE CONSIDERATION GIVEN IN EXCHANGE FOR THE ISSUANCE OF THIS REPORT, RECIPIENT AGREES THAT FIRST AMERICAN'S SOLE LIABILITY FOR ANY LOSS OR DAMAGE CAUSED BY AN ERROR OR OMISSION DUE TO INACCURATE INFORMATION OR NEGLIGENCE IN PREPARING THIS REPORT SHALL BE LIMITED TO THE FEE CHARGED FOR THE REPORT. RECIPIENT ACCEPTS THIS REPORT WITH THIS LIMITATION AND AGREES THAT FIRST AMERICAN WOULD NOT HAVE ISSUED THIS REPORT BUT FOR THE LIMITATION OF LIABILITY DESCRIBED ABOVE. FIRST AMERICAN MAKES NO REPRESENTATION OR WARRANTY AS TO THE LEGALITY OR PROPRIETY OF RECIPIENT'S USE OF THE INFORMATION HEREIN.
 - (b) No costs (including, without limitation attorney fees and other expenses) of defense, or prosecution of any action, is afforded to the Customer.
 - (c) In any event, the Company assumes no liability for loss or damage by reason of the following:
 - (1) Taxes or assessments which are not shown as existing liens by the records of any taxing authority that levies taxes or assessments on real property or by the Public Records.
 - (2) Any facts, rights, interests or claims which are not shown by the Public Records but which could be ascertained by an inspection of the land or by making inquiry of persons in possession thereof.
 - (3) Easements, liens or encumbrances, or claims thereof, which are not shown by the Public Records.
 - (4) Discrepancies, encroachments, shortage in area, conflicts in boundary lines or any other facts which a survey would disclose.
 - (5) (i) Unpatented mining claims; (ii) reservations or exceptions in patents or in Acts authorizing the issuance thereof, (iii) water rights or claims or title to water.
 - (6) Any right, title, interest, estate or easement in land beyond the lines of the area specifically described or referred to in this report, or in abutting streets, roads, avenues, alleys, lanes, ways or waterways.
 - (7) Any law, ordinance or governmental regulation (including but not limited to building and zoning laws, ordinances or regulations) restricting, regulating, prohibiting or relating to (i) the occupancy, use or enjoyment on the land; (ii) the character, dimensions or location of any improvement now or hereafter erected on the land; (iii) a separation in ownership or a change in the dimensions or area of the land or any parcel of which the land is or was a part; or (iv) environmental protection, or the effect of any violation of these laws, ordinances or governmental regulations, except to the extent that a notice of the enforcement thereof or a notice of a defect, lien or encumbrance resulting from a violation or alleged violation affecting the land has been recorded in the Public Records at the effective date hereof.
 - (8) Any governmental police power not excluded by 2(d)(7) above, except to the extent that notice of the exercise thereof or a notice of a defect, lien or encumbrance resulting from a violation or alleged violation affecting the land has been recorded in the Public Records at the effective date hereof.
 - (9) Defects, liens, encumbrances, adverse claims or other matters created, suffered, assumed, agreed to or actually known by the Customer.

3. **Charge.** The charge for this report does not include supplemental reports, updates or other additional services of the Company.



First American

First American Title Insurance Company
775 NE Evans Street
McMinnville, OR 97128

Illegal Restrictive Covenants

Please be advised that any provision contained in this document, or in a document that is attached, linked, or referenced in this document, that under applicable law illegally discriminates against a class of individuals based upon personal characteristics such as race, color, religion, sex, sexual orientation, gender identity, familial status, disability, national origin, or any other legally protected class, is illegal and unenforceable by law.

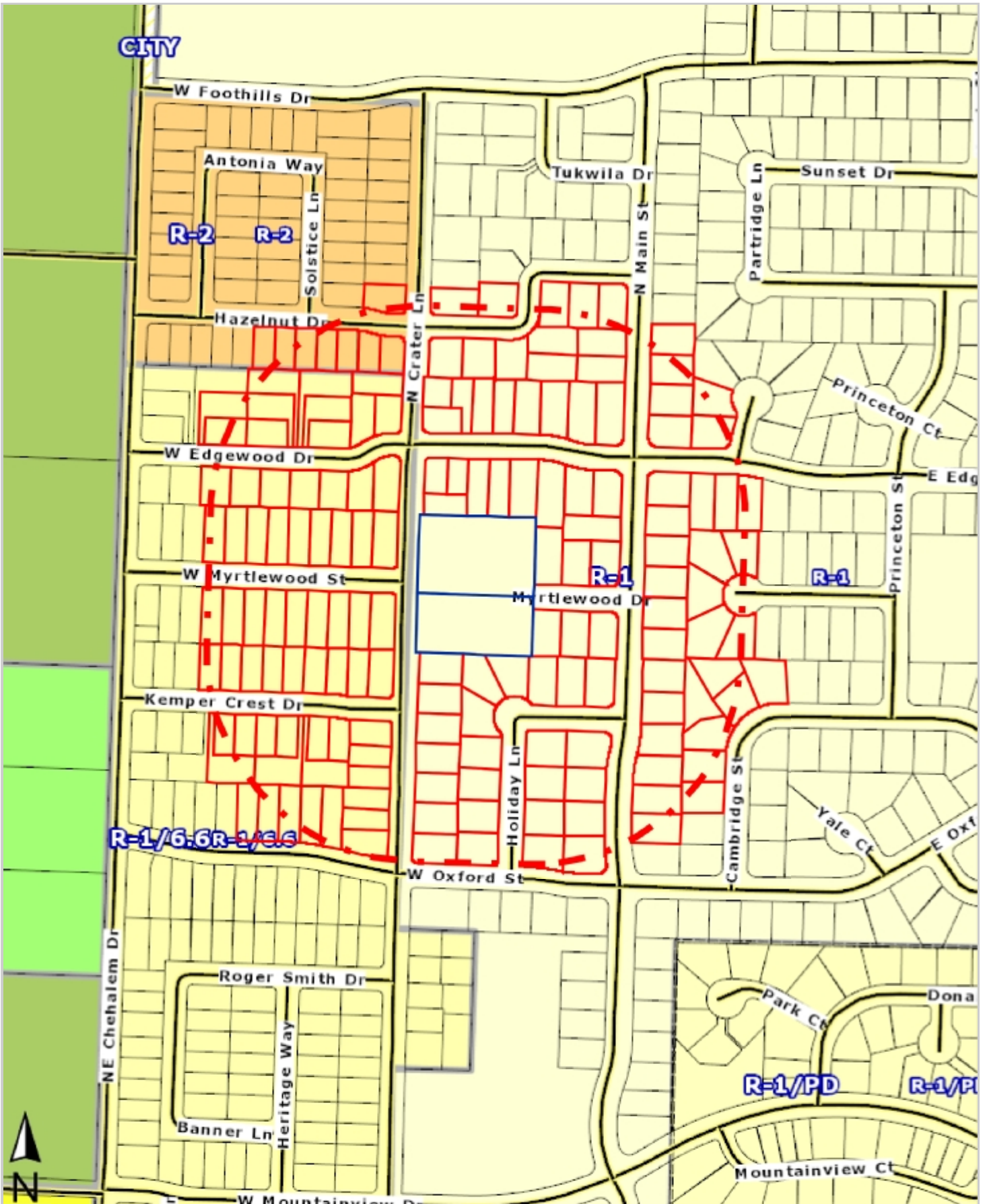

TICOR TITLE™

This map/plat is being furnished as an aid in locating the herein described land in relation to adjoining streets, natural boundaries and other land, and is not a survey of the land depicted. Except to the extent a policy of title insurance is expressly modified by endorsement, if any, the company does not insure dimensions, distances, location of easements, acreage or other matters shown thereon.

519757	2.5	2315	7744 2709 Holiday Ln	Newberg	Diethl, Mark E	Kathryn	Diethl, Kathryn E	OR	97132	2004 R-1
519760	2.5	2138	7570 2719 Holiday Ln	Newberg	Diethl, Mark E	Andrew	Diethl, Mark E	OR	97132	2003 R-1
519763	3	2472	7601 2729 Holiday Ln	Newberg	Diethl, Mark E	Andrew	Diethl, Mark E	OR	97132	2003 R-1
519766	2.5	2487	8119 2735 Holiday Ln	Newberg	Adam, Larry	Larry	Adam, Larry	OR	97132	2003 R-1
519769	2.5	2729	8154 2750 Holiday Ln	Newberg	Adam, James F	James	Adam, James F	OR	97132	2003 R-1
519772	2	1836	7858 2718 Holiday Ln	Newberg	Drey, Joseph T	Joseph	Drey, Joseph T	OR	97132	2003 R-1
519775	2	1888	7858 2708 Holiday Ln	Newberg	Phinno, Christopher	Christopher	Phinno, Christopher	OR	97132	2003 R-1
519778	2.5	2050	7771 2863 NE Elbert Ave	Newberg	Haines David Living Trust	David	Haines David Living Trust	OR	97132	2003 R-1
528925	2.5	1395	7501 319 Cambridge St	Newberg	Quinn, Jamie	Jamie	Quinn, Jamie	OR	97132	2004 R-1
528928	2.5	1395	7501 319 Cambridge St	Newberg	Quinn, Jamie	Jamie	Quinn, Jamie	OR	97132	2004 R-1
528931	2.5	1344	7868 309 Cambridge St	Newberg	Caldwell, Bradley K	Bradley	Caldwell, Bradley K	OR	97132	2003 R-1
528934	2.5	1344	7868 309 Cambridge St	Newberg	Caldwell, Bradley K	Bradley	Caldwell, Bradley K	OR	97132	2003 R-1
528937	2.5	2431	6337 3115 Carter Ln	Newberg	Sturdevant, Tyler D	Tyler	Sturdevant, Tyler D	OR	97132	2004 R-1/6.6
528942	2.5	2809	5945 301 W Edgewood Dr	Newberg	Redlich, Paula A Trustee	Paula	Redlich, Paula A Trustee	OR	97132	2004 R-1/6.6
528945	2.5	2835	6749 305 W Edgewood Dr	Newberg	Burger, Shannon M	Shannon	Burger, Shannon M	OR	97132	2005 R-1/6.6
528948	2.5	3428	6486 311 W Edgewood Dr	Newberg	Burger, Shannon M	Shannon	Burger, Shannon M	OR	97132	2005 R-1/6.6
528951	2.5	2897	7562 315 W Edgewood Dr	Newberg	Kent, Henry A	Henry	Kent, Henry A	OR	97132	2004 R-1/6.6
528954	2.5	2981	9108 321 W Edgewood Dr	Newberg	Swanson, Marilyn Trust	Marilyn	Swanson, Marilyn Trust	OR	97132	2004 R-1/6.6
528957	2.5	2854	9112 325 W Edgewood Dr	Newberg	Banagyan, Mary R	Mary	Banagyan, Mary R	OR	97132	2004 R-1/6.6
528960	2.5	2854	7562 331 W Edgewood Dr	Newberg	Schneekloth, Ronald J Trustee	Ronald	Schneekloth, Ronald J Trustee	OR	97132	2004 R-1/6.6
528963	2.5	4	3356 5699 335 W Edgewood Dr	Newberg	Johnson, Jamie	Jamie	Johnson, Jamie	OR	97132	2005 R-1/6.6
528966	2	1764	5699 335 W Edgewood Dr	Newberg	Johnson, Jamie	Jamie	Johnson, Jamie	OR	97132	2005 R-1/6.6
528969	3	3180	7562 423 S W Edgewood Dr	Newberg	Squires, Edwin R	Edwin	Squires, Edwin R	OR	97132	2005 R-1/6.6
528970	2.5	2872	8529 408 W Edgewood Dr	Newberg	Higgins, Philip E	Philip	Higgins, Philip E	OR	97132	2005 R-1/6.6
528973	2.5	2885	8529 408 W Edgewood Dr	Newberg	Kramer, Mariah A	Mariah	Kramer, Mariah A	OR	97132	2005 R-1/6.6
528976	2.5	2885	8529 408 W Edgewood Dr	Newberg	Kramer, Mariah A	Mariah	Kramer, Mariah A	OR	97132	2005 R-1/6.6
528979	2.5	2907	8529 408 W Edgewood Dr	Newberg	Huford, Amy	Amy	Huford, Amy	OR	97132	2004 R-1/6.6
528982	2.5	3021	6946 320 W Edgewood Dr	Newberg	Brandeau, Brad	Brad	Brandeau, Brad	OR	97132	2004 R-1/6.6
528985	2.5	2761	6351 312 W Edgewood Dr	Newberg	Kirk, Brenda	Brenda	Kirk, Brenda	OR	97132	2005 R-1/6.6
528988	2.5	3040	6354 306 W Edgewood Dr	Newberg	Gesser, Ryan W	Ryan	Gesser, Ryan W	OR	97132	2004 R-1/6.6
528991	2.5	2710	6080 300 W Edgewood Dr	Newberg	Toohy, John P	John	Toohy, John P	OR	97132	2005 R-1/6.6
528994	2.5	3263	7527 134 Hazelnd Dr	Newberg	Gass, John A	John	Gass, John A	OR	97132	2005 R-1/6.6
528997	2.5	4	2979 7501 200 Hazelnd Dr	Newberg	Strilling, Christopher	Christopher	Strilling, Christopher	OR	97132	2005 R-1/6.6
528999	2.5	2824	7501 220 Hazelnd Dr	Newberg	Eich, David M	David	Eich, David M	OR	97132	2004 R-1/6.6
529002	2.5	3056	7501 220 Hazelnd Dr	Newberg	Eich, David M	David	Eich, David M	OR	97132	2004 R-1/6.6
529005	2.5	2879	7501 225 W Hazelnd Dr	Newberg	Bevely, A	A	Bevely, A	OR	97132	2006 R-1/6.6
529008	2.5	3312	7501 225 W Hazelnd Dr	Newberg	Kousto, Andrew J	Andrew	Kousto, Andrew J	OR	97132	2004 R-1/6.6
529011	2.5	4	2079 8187 303 W Myrtlewood St	Newberg	Sponseller, Robert D	Robert	Sponseller, Robert D	OR	97132	2004 R-1/6.6
529014	2.5	1588	6843 313 W Myrtlewood St	Newberg	Carr, Nikki E	Nikki	Carr, Nikki E	OR	97132	2005 R-1/6.6
529017	2.5	2050	6849 312 W Myrtlewood St	Newberg	Lawson, Judy I	Judy	Lawson, Judy I	OR	97132	2005 R-1/6.6
529020	2.5	2050	6849 312 W Myrtlewood St	Newberg	Lawson, Judy I	Judy	Lawson, Judy I	OR	97132	2005 R-1/6.6
529023	2.5	2050	6849 312 W Myrtlewood St	Newberg	Lawson, Judy I	Judy	Lawson, Judy I	OR	97132	2005 R-1/6.6
529026	2.5	1834	6847 345 W Myrtlewood St	Newberg	Hampton, Lawrence R	Lawrence	Hampton, Lawrence R	OR	97132	2005 R-1/6.6
529029	2.5	2030	6847 345 W Myrtlewood St	Newberg	Hampton, Lawrence R	Lawrence	Hampton, Lawrence R	OR	97132	2005 R-1/6.6
529032	2.5	1995	6847 345 W Myrtlewood St	Newberg	Ammons, Timothy L	Timothy	Ammons, Timothy L	OR	97132	2005 R-1/6.6
529035	2.5	2816	6851 411 W Myrtlewood St	Newberg	Jones, Megan L	Megan	Jones, Megan L	OR	97132	2005 R-1/6.6
529038	2.5	2574	6851 411 W Myrtlewood St	Newberg	Johnsee, Craig R	Craig	Johnsee, Craig R	OR	97132	2005 R-1/6.6
529041	2.5	2452	6856 410 W Myrtlewood St	Newberg	Healy, Griff	Griff	Healy, Griff	OR	97132	2005 R-1/6.6
529044	2.5	2452	6856 410 W Myrtlewood St	Newberg	Wilson, Robert E	Robert	Wilson, Robert E	OR	97132	2005 R-1/6.6
529047	2.5	2088	6856 402 W Myrtlewood St	Newberg	Chamberlin, Wyatt B	Wyatt	Chamberlin, Wyatt B	OR	97132	2005 R-1/6.6
529050	2.5	2460	6856 344 W Myrtlewood St	Newberg	Bonz, Carlos D	Carlos	Bonz, Carlos D	OR	97132	2005 R-1/6.6
529053	2.5	1734	6856 336 W Myrtlewood St	Newberg	McVey, Barton E	Barton	McVey, Barton E	OR	97132	2004 R-1/6.6
529056	2.5	2046	6856 328 W Myrtlewood St	Newberg	Tabor, Jack D	Jack	Tabor, Jack D	OR	97132	2004 R-1/6.6
529059	2.5	2248	6850 320 W Myrtlewood St	Newberg	Probst, Michael	Michael	Probst, Michael	OR	97132	2005 R-1/6.6
529062	2.5	1874	6850 4408 Birchaven Ln	Newberg	Probst, Michael	Michael	Probst, Michael	OR	97132	2005 R-1/6.6
529065	2.5	2168	8215 302 W Myrtlewood St	Newberg	Primer, Dale B Trustee	Dale	Primer, Dale B Trustee	OR	97132	2005 R-1/6.6
529068	2.5	1969	6307 305 Hazelnd Dr	Newberg	Nix, Joshua	Joshua	Nix, Joshua	OR	97132	2005 R-1/6.6
529071	2.5	1868	5052 300 Hazelnd Dr	Newberg	Nix, Jennifer	Jennifer	Nix, Jennifer	OR	97132	2003 R-2
529074	2.5	2000	5013 1776 5th Ave E	Newberg	Nix, Jennifer	Jennifer	Nix, Jennifer	OR	97132	2003 R-2
529077	2.5	2185	5022 312 Hazelnd Dr	Newberg	Nix, Jennifer	Jennifer	Nix, Jennifer	OR	97132	2003 R-2
529080	2.5	2185	5022 312 Hazelnd Dr	Newberg	Nix, Jennifer	Jennifer	Nix, Jennifer	OR	97132	2003 R-2
529083	2.5	2081	5000 324 Hazelnd Dr	Newberg	Rosenberry, Timothy	Timothy	Rosenberry, Timothy	OR	97132	2005 R-2
529086	2.5	2420	5000 406 Hazelnd Dr	Newberg	Zwickler, Matthew A	Matthew	Zwickler, Matthew A	OR	97132	2005 R-2
529089	2.5	2481	5000 424 Hazelnd Dr	Newberg	Duff, Derek G	Derek	Duff, Derek G	OR	97132	2005 R-2
529092	2.5	2481	5000 424 Hazelnd Dr	Newberg	Owen, Kristina M	Kristina	Owen, Kristina M	OR	97132	2005 R-2
529095	2.5	1916	5882 303 Kemper Crest Dr	Newberg	Gaut, Stefan	Stefan	Gaut, Stefan	OR	97132	2005 R-2
529098	2.5	2484	5741 311 W Kemper Crest Dr	Newberg	Reed, Frank	Frank	Reed, Frank	OR	97132	2005 R-1/6.6
529101	2.5	2078	5513 2250 SW Fairview Dr	Newberg	Metzloff, Renee L	Renee	Metzloff, Renee L	OR	97132	2005 R-1/6.6
529104	2.5	2288	6050 329 Kemper Crest Dr	Newberg	Conrow, Derek	Derek	Conrow, Derek	OR	97132	2005 R-1/6.6
529107	2.5	2356	5501 335 Kemper Crest Dr	Newberg	Gaunt, Brian M	Brian	Gaunt, Brian M	OR	97132	2005 R-1/6.6
529110	2.5	2356	5501 335 Kemper Crest Dr	Newberg	Gaunt, Brian M	Brian	Gaunt, Brian M	OR	97132	2005 R-1/6.6

529566	2.5	2478	5501 343 Kemper Crest Dr	Newberg	Machis, Nicholas	Machis, Ganb	Ganb	Machis	Nicholas	Machis	529566	OR	97132 343 Kemper Crest Dr	Newberg	97132 2005 R-1/6.6
529669	2.5	2483	5501 401 Kemper Crest Dr	Newberg	Becker, Christina D	Becker, Bruce	Bruce	Becker	Christina	Becker	529669	OR	97132 401 Kemper Crest Dr	Newberg	97132 2005 R-1/6.6
529672	2.5	1916	5501 409 Kemper Crest Dr	Newberg	Ericson, Mark J	Ericson, Jonathan R	Jonathan	Ericson	Mark	Ericson	529672	OR	97132 409 Kemper Crest Dr	Newberg	97132 2005 R-1/6.6
529702	3	2094	5501 PO Box 857	Newberg	Kemper Crest LLC	Kemper Crest LLC	Kemper Crest LLC	Kemper Crest LLC		Kemper Crest LLC	529702	OR	97132 412 Kemper Crest Dr	Newberg	97132 2005 R-1/6.6
529705	3	2187	8720 412 Kemper Crest Dr	Newberg	Swenson, Steven M	Swenson, Jennifer	Jennifer	Swenson	Steven	Swenson	529705	OR	97132 412 Kemper Crest Dr	Newberg	97132 2005 R-1/6.6
529708	2.5	2256	5000 400 Kemper Crest Dr	Newberg	Ortizola, Ricardo	Valenzuela, Jessica	Jessica	Ortizola	Ricardo	Ortizola	529708	OR	97132 400 Kemper Crest Dr	Newberg	97132 2005 R-1/6.6
529711	2.5	1916	5000 400 Kemper Crest Dr	Newberg	Smith, Nathan J	Smith, Nathan	Nathan	Smith	Nathan	Smith	529711	OR	97132 400 Kemper Crest Dr	Newberg	97132 2005 R-1/6.6
529714	2.5	2229	5000 342 Kemper Crest Dr	Newberg	Church Bradley R	Church Vahia A	Nancy	Paetzman	Thomas	Church Bradley R	529714	OR	97132 342 Kemper Crest Dr	Newberg	97132 2005 R-1/6.6
529717	3.5	2078	5000 394 Kemper Crest Dr	Newberg	Paetzman, Thomas	Paetzman, Nancy	Nancy	Paetzman	Thomas	Paetzman	529717	OR	97132 394 Kemper Crest Dr	Newberg	97132 2005 R-1/6.6
529720	3	2758	8720 332 Kemper Crest Dr	Newberg	Killen, Lauralee C	Foster, Sarah E	Sarah	Foster	Lauralee	Killen	529720	OR	97132 332 Kemper Crest Dr	Newberg	97132 2005 R-1/6.6
529723	2.5	1916	8720 330 Kemper Crest Dr	Newberg	Foster, Daniel H	Foster, Daniel	Daniel	Foster	Daniel	Foster	529723	OR	97132 330 Kemper Crest Dr	Newberg	97132 2005 R-1/6.6
529726	2.5	2478	5248 607 N Homwood Dr	Newberg	Aquila Sylvia J Living Trust	Bates, Shannon L	Shannon L	Bates	Christopher A	Aquila Sylvia J Living Trust	529726	AZ	55048 318 Kemper Crest Dr	Newberg	97132 2005 R-1/6.6
529729	2.5	2356	5993 2727 Crater Ln	Newberg	Boerio, Jeffrey P	Boerio, Jeffrey P	Jeffrey P	Boerio	Jeffrey	Boerio	529729	OR	97132 2727 N Crater Ln	Newberg	97132 2005 R-1/6.6
529732	2.5	2478	5157 2711 N Crater Ln	Newberg	Bechtold, Jamie R	Bauer, Kathryn E	Kathryn	Bauer	Nathan	Bechtold	529732	OR	97132 2711 N Crater Ln	Newberg	97132 2005 R-1/6.6
529735	2.5	2066	5157 2711 N Crater Ln	Newberg	Shrock, David	Shrock, Jill E	Jill	Shrock	David	Shrock	529735	OR	97132 2708 N Crater Ln	Newberg	97132 2005 R-1/6.6
529869	2	1731	5686 2709 N Crater Ln	Newberg	Chase, Nathan R	Chase, Patricia	Patricia	Chase	Nathan R	Chase	529869	OR	97132 2709 N Crater Ln	Newberg	97132 2005 R-1/6.6
530672	2.5	2460	6645 2703 N Crater Ln	Newberg	Almqvist, Nancy N	Almqvist, Nancy	Nancy	Almqvist	Paul	Almqvist	530672	OR	97132 2703 N Crater Ln	Newberg	97132 2005 R-1/6.6
530675	2.5	2000	7347 323 W Oxford St	Newberg	Almqvist, Nancy N	Almqvist, Nancy	Nancy	Almqvist	Paul	Almqvist	530675	OR	97132 323 W Oxford St	Newberg	97132 2005 R-1/6.6
530678	2.5	2485	7013 331 W Oxford St	Newberg	Sherrard, Brian R	Sherrard, Brian R	Brian	Sherrard	Brian	Sherrard	530678	OR	97132 331 W Oxford St	Newberg	97132 2005 R-1/6.6
530681	2.5	2305	6860 337 W Oxford St	Newberg	Sherrard, Brian R	Sherrard, Brian R	Brian	Sherrard	Brian	Sherrard	530681	OR	97132 345 W Oxford St	Newberg	97132 2005 R-1/6.6
530684	1.5	2485	6861 345 W Oxford St	Newberg	Sherrard, Brian R	Sherrard, Brian R	Brian	Sherrard	Brian	Sherrard	530684	OR	97132 345 W Oxford St	Newberg	97132 2005 R-1/6.6
530687	1.5	2090	6861 345 W Oxford St	Newberg	Sherrard, Brian R	Sherrard, Brian R	Brian	Sherrard	Brian	Sherrard	530687	OR	97132 345 W Oxford St	Newberg	97132 2005 R-1/6.6
530690	2.5	2248	6861 403 N Oxford St	Newberg	Roh, Charles	Roh, Charles	Charles	Roh	Charles	Roh	530690	OR	97132 403 N Oxford St	Newberg	97132 2005 R-1/6.6
532552	2.5	2093	7496 2718 N Crater Ln	Newberg	Till, Colleen E	Monica	Monica	Cox	Colleen	Till	532552	OR	97132 2718 N Crater Ln	Newberg	97132 2005 R-1/6.6
532555	2.5	2795	7496 2718 N Crater Ln	Newberg	Scharfenberger, Kris H	Scharfenberger, Emily M	Emily	Scharfenberger	Kris	Scharfenberger	532555	OR	97132 2718 N Crater Ln	Newberg	97132 2005 R-1/6.6
532558	2.5	2630	7496 2714 N Crater Ln	Newberg	Klus, Timothy W Jr	Klus, Jessica D	Jessica	Klus	Timothy	Klus Jr	532558	OR	97132 2714 N Crater Ln	Newberg	97132 2006 R-1/6.6
532561	2.5	2489	7501 2740 N Crater Ln	Newberg	Engle, Frank Jr	Engle, Janelle	Janelle	Engle	Frank	Engle Jr	532561	OR	97132 2740 N Crater Ln	Newberg	97132 2006 R-1/6.6
535457	2.5	2610	5548 2990 Crater Ln	Newberg	Key, Robert P	Key, Laura N	Laura	Key	Robert	Key	535457	OR	97132 2990 N Crater Ln	Newberg	97132 2015 R-1/6.6
535460	2.5	2243	5244 229 W Edgewood Dr	Newberg	Caughlin, Justin	Caughlin, Hillary	Hillary	Caughlin	Justin	Caughlin	535460	OR	97132 229 W Edgewood Dr	Newberg	97132 2015 R-1/6.6
535463	3	2613	6604 219 W Edgewood Dr	Newberg	Meadows, Benjamin A	Meadows, Cassandra L	Cassandra	Meadows	Benjamin	Caughlin	535463	OR	97132 219 W Edgewood Dr	Newberg	97132 2015 R-1/6.6
535466	2.5	2654	6584 209 W Edgewood Dr	Newberg	Keenan, Alyssa E	Keenan, Alyssa R	Alyssa	Keenan	Samuel	Keenan	535466	OR	97132 209 W Edgewood Dr	Newberg	97132 2015 R-1/6.6
535469	3	2613	6917 210 W Edgewood Dr	Newberg	Fulcher, Justin	Fulcher, Kate	Kate	Fulcher	Justin	Fulcher	535469	OR	97132 210 W Edgewood Dr	Newberg	97132 2015 R-1/6.6
535472	2.5	2247	6878 220 W Edgewood Dr	Newberg	Edwards, Richard II	Edwards, Amanda	Amanda	Edwards	Richard	Edwards II	535472	OR	97132 220 W Edgewood Dr	Newberg	97132 2014 R-1/6.6
535475	2.5	2247	4938 230 W Edgewood Dr	Newberg	Roberson, Gregory W	Roberson, Kimberly A	Kimberly	Roberson	Gregory	Roberson	535475	OR	97132 230 W Edgewood Dr	Newberg	97132 2015 R-1/6.6
535478	2.5	2159	4517 8682 SW Holy Ln Apt 503	Newberg	Barnes-Cosdon, Matthew	Barnes-Cosdon, Matthew	Matthew	Barnes-Cosdon	Gregory	Barnes-Cosdon	535478	OR	97132 230 W Edgewood Dr	Newberg	97132 2015 R-1/6.6
535481	2	2547	5135 2950 Crater Ln	Newberg	Francis, Brian G	Francis, Camille S	Camille	Francis	Brian	Francis	535481	OR	97132 2950 N Crater Ln	Newberg	97132 2015 R-1/6.6

Land Use Notice

FILE # SUB221-0002

PROPOSAL: 10 Lot Residential Subdivision

FOR FURTHER INFORMATION, CONTACT:

City of Newberg

Community Development Department

414 E. First Street

Phone: 503-537-1240

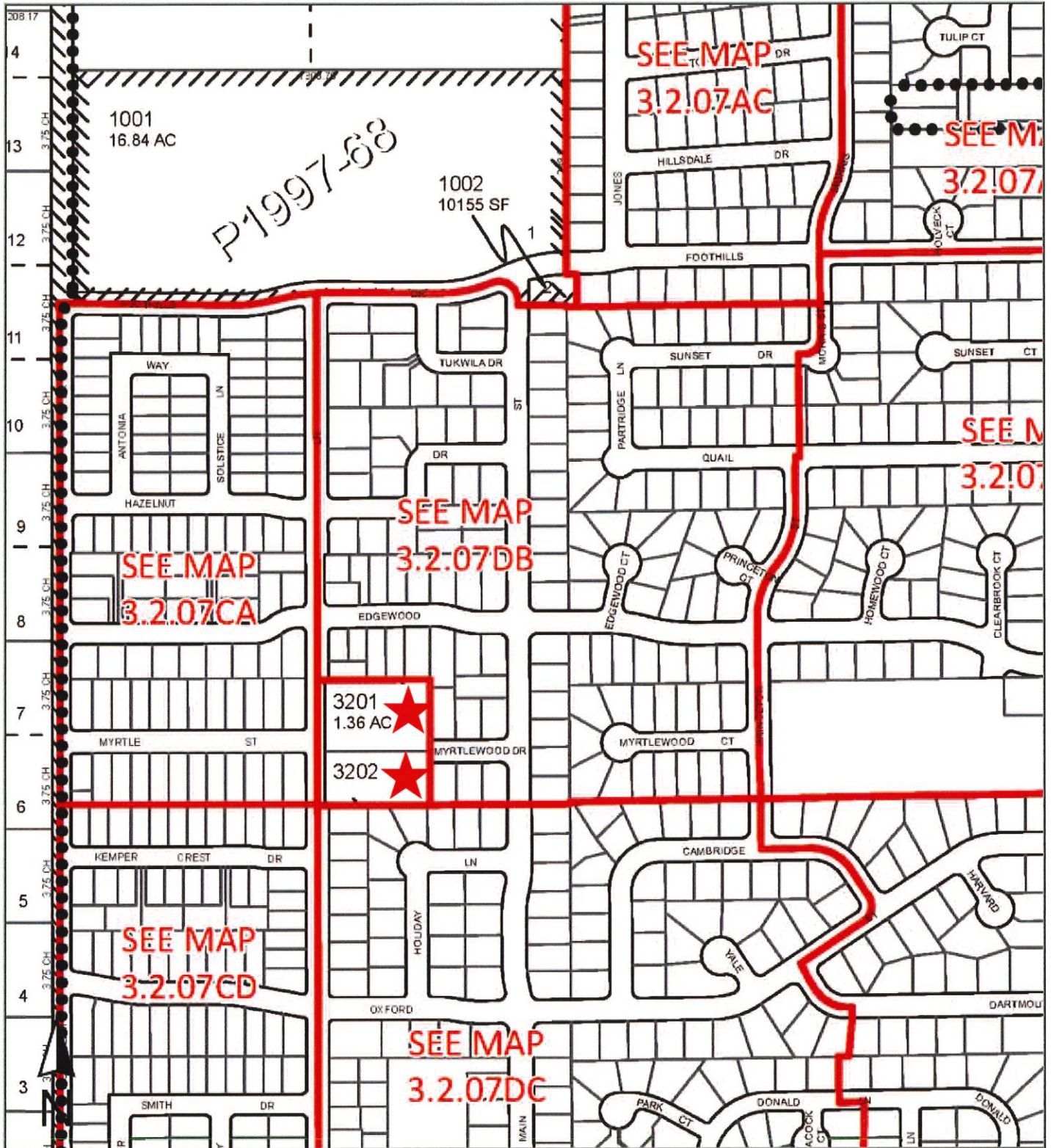

ParcelID: 428451
2900 N Crater Ln
Newberg, OR 97132

This map/plot is being furnished as an aid in locating the herein described land in relation to adjoining streets, natural boundaries and other land, and is not a survey of the land depicted. Except to the extent a policy of title insurance is expressly modified by endorsement, if any, the company does not insure dimensions, distances, location of easements, acreage or other matters shown thereon.

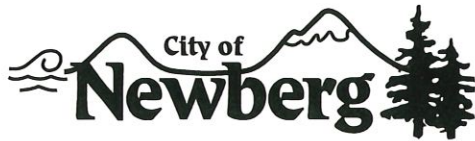

Community Development Department

P.O. Box 970 • 414 E First Street • Newberg, Oregon 97132
503-537-1240. Fax 503-537-1272 www.newbergoregon.gov

WE WANT YOUR COMMENTS ON A PROPOSED NEW DEVELOPMENT IN YOUR NEIGHBORHOOD

A property owner in your neighborhood submitted an application to the City of Newberg to subdivide a parcel of land from *one (1)* lot into *ten (10)* separate lots. You are invited to take part in the City's review of this project by sending in your written comments. You also may request that the Planning Commission hold a hearing on the application. For more details about giving comments, please see the back of this sheet.

The development would include a 10 Lot residential subdivision in the Low-Density Residential District (R-1) with lots ranging between 4,244 square feet to 5,956 square feet in size, with an average lot size of 5,023 square feet. Myrtlewood Drive will be extended through the site to connect with N Crater Ln. and a stormwater pond will be provided as part of the development. The proposal will be developed pursuant to the applicable criteria of the City of Newberg Municipal Code (NMC) requirements.

APPLICANT: ***Emerio Design, LLC – Steve Miller***
TELEPHONE: ***(503) 746 - 8812***

PROPERTY OWNER: ***Fred L. Sparks and Estate of Linda Jean Hamlett***

LOCATION: ***2900 N Crater Ln.***

TAX LOT NUMBER: ***Tax Map 3-2-07; Tax Lot 3202***

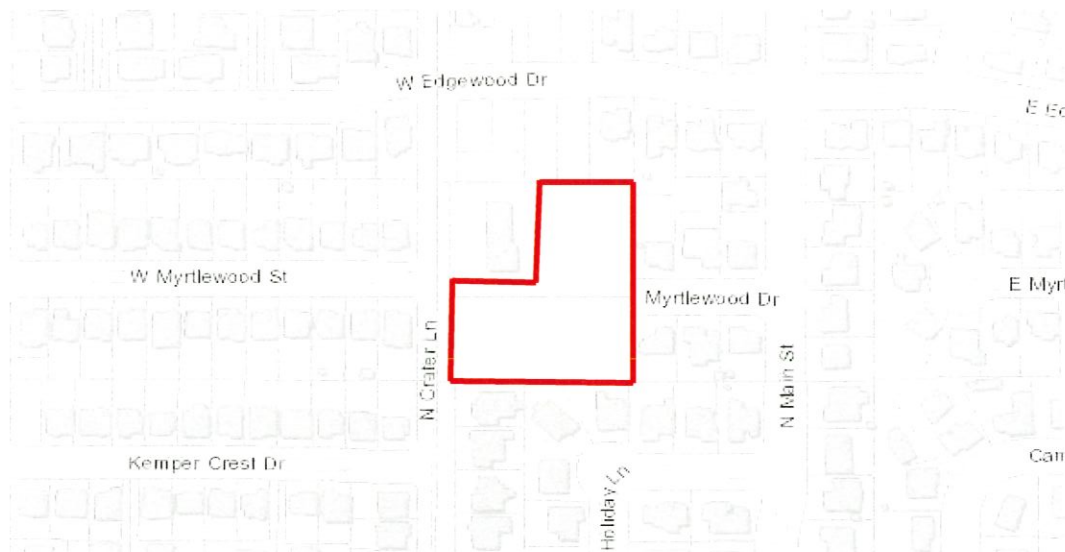

Working Together For A Better Community-Serious About Service"

<https://www.codepublishing.com/OR/Newberg/#!/Newberg15/Newberg15.html>

We are mailing you information about this project because you own land within 500 feet of the proposed new project. We invite you to send any written comments for or against the proposal within 14 days from the date this notice is mailed. You also may request that the Newberg Planning Commission hold a hearing on the application by sending a written request during this 14-day period and identifying the issues you would like the Planning Commission to address.

If you mail your comments to the City, please put the following information on the outside of the envelope:

Written Comments: File No. SUB221-0002
Newberg Community Development Department
PO Box 970
Newberg, OR 97132

All written comments must be turned in by 4:30 p.m. on XXXX XX, 2021. Any issue which might be raised in an appeal of this case to the Land Use Board of Appeals (LUBA) must be submitted to the City in writing before this date. You must include enough detail to enable the decision maker an opportunity to respond. The applicable criteria used to make a decision on this application for preliminary subdivision plan approval are found in Newberg Development Code 15.235.050(A).

You can look over all the information about this project or drop comments off at Newberg City Hall, 414 E. First Street. You can also buy copies of the information for a cost of 25 cents a page. If you have any questions about the project, you can call the Newberg Planning Division at 503-537-1240.

The Community Development Director will make a decision at the end of a 14-day comment period. If you send in written comments about this project, you will be sent information about any decision made by the City relating to this project.

Date Mailed: **XXXX XX, 2021**

2900 SW CARTER LN. VICINITY MAP

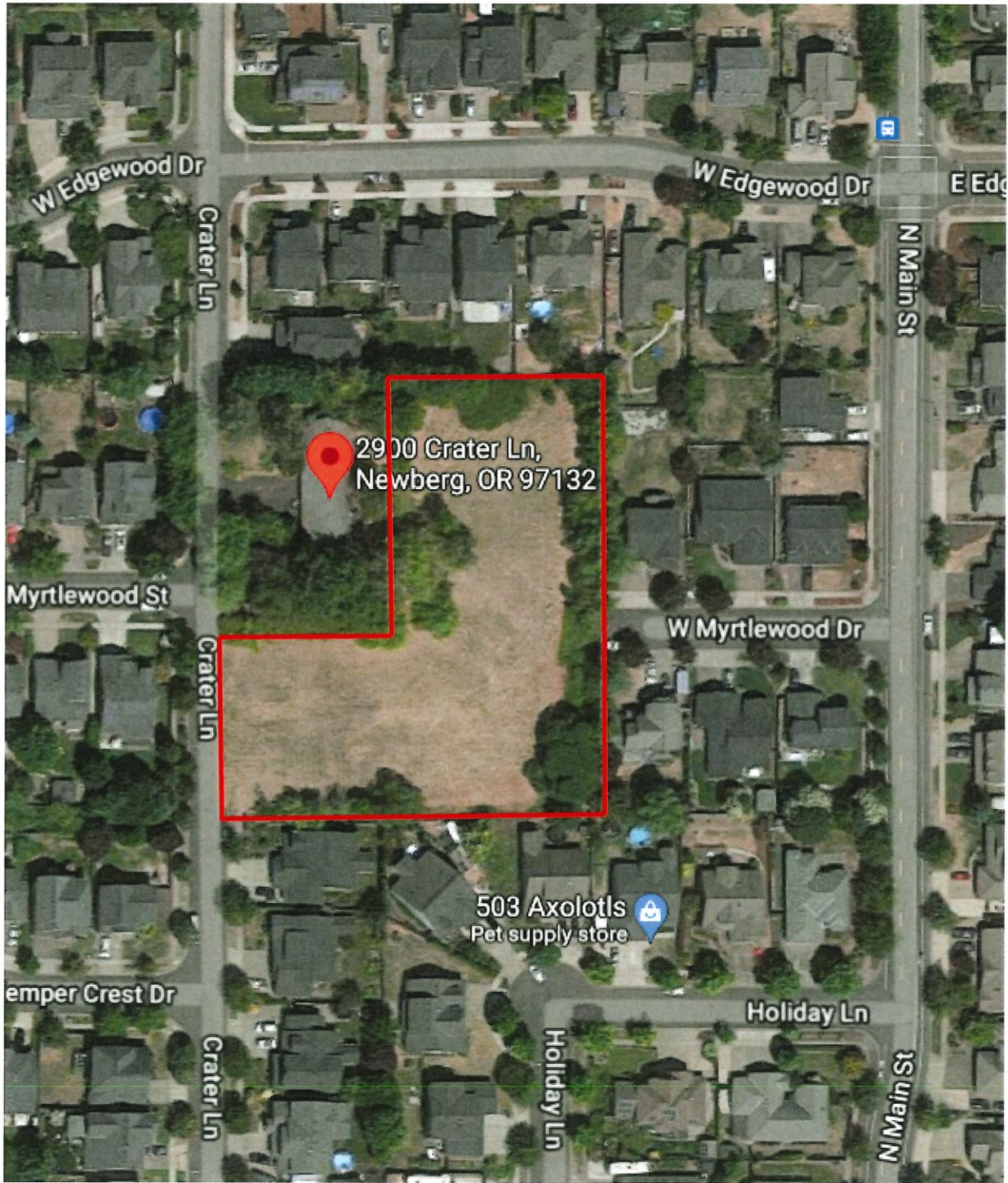



ASSESSMENT & TAX
CARTOGRAPHY

SECTION 7 T.3S. R.2W. W.M.
YAMHILL COUNTY OREGON
1" = 400'

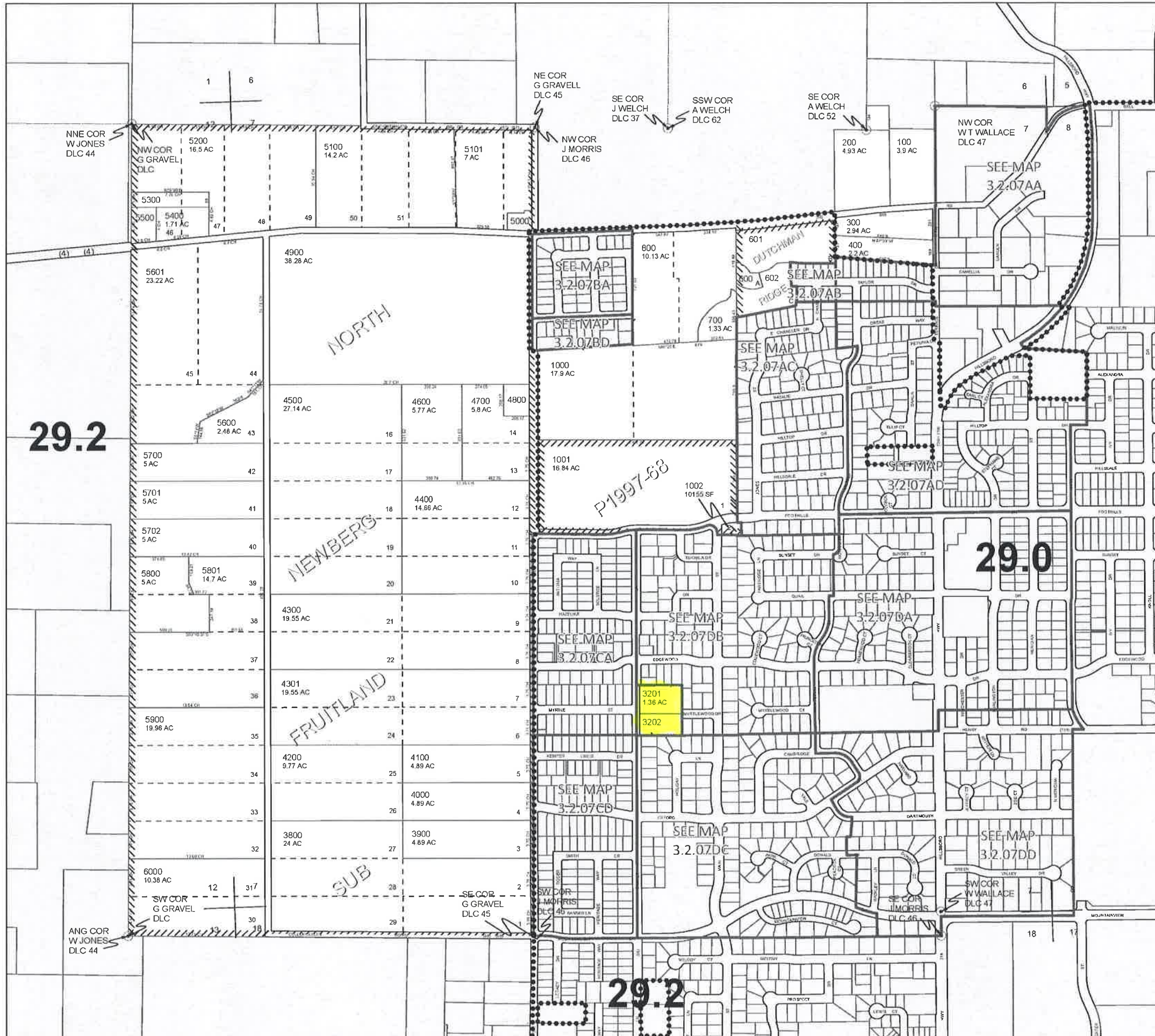

CANCELLED TAXLOTS:

- 3704 1801
- 3703 1800
- 3702 1700
- 3701 1600
- 3700 1500
- 3600 1400
- 3500 1300
- 3400 1200
- 3300 1100
- 3203 1003
- 3200 500
- 3100
- 3002
- 3001
- 3000
- 2900
- 2800
- 2700
- 2600
- 2503
- 2502
- 2501
- 2500
- 2400
- 2300
- 2200
- 2100
- 2000
- 1901
- 1900

DATE PRINTED: 11/14/2019

This product is for Assessment and Taxation (A&T) purposes only and has not been prepared or is suitable for legal, engineering, surveying or any purposes other than assessment and taxation.

Wetland Delineation for 2900 Crater Lane Newberg, Oregon

(Township 3 South, Range 2 West, Section 7,
Tax Lots 3201 (portion) and 3202)

Prepared for

Nick Daniken

Greenwing Companies

16869 SW 65th Ave., Suite 115

Lake Oswego, OR 97035

Prepared by

Michael See

Amy Hawkins

John van Staveren

Pacific Habitat Services, Inc.

Wilsonville, Oregon 97070

(503) 570-0800

(503) 570-0855 FAX

PHS Project Number: 7299

August 2021



TABLE OF CONTENTS

	<u>Page</u>
I. INTRODUCTION.....	1
II. RESULTS AND DISCUSSION	1
A. Landscape Setting and Land Use.....	1
B. Site Alterations.....	1
C. Precipitation Data and Analysis.....	1
D. Methods	3
E. Description of All Wetlands and Other Non-Wetland Waters	3
F. Deviation from Local and/or National Wetland Inventories	4
G. Mapping Method.....	4
H. Additional Information	4
I. Results and Conclusions	4
J. Disclaimer.....	4
III. REFERENCES.....	5
APPENDIX A: Figures	
Figure 1: Vicinity Map (USGS)	
Figure 2: Tax Lot Map	
Figure 3: Wetland Inventory Map (National)	
Figure 4: Soil Survey Map	
Figure 5: Aerial Photo	
Figure 6: Potentially Jurisdictional Wetland (Wetland Delineation Map)	
APPENDIX B: Wetland Delineation Data Sheets	
APPENDIX C: Site photos (ground level)	
APPENDIX D: Wetland Definitions and Methodology (Client only)	

I. INTRODUCTION

Pacific Habitat Services, Inc. (PHS) conducted a wetland delineation for the property located at 2900 Crater Lane, in Newberg, Yamhill County, Oregon (Township 3 South, Range 2 West, Section 7, Tax Lots 3201 (portion) and 3202. This report presents the results of PHS's wetland delineation within the study area. Figures, including a map depicting the location of wetlands within the study area, are located in Appendix A. Data sheets documenting on-site conditions are in Appendix B. Ground-level photos of the site are located in Appendix C. A discussion of the wetland delineation methodology, provided for the client, is in Appendix D.

II. RESULTS AND DISCUSSION

A. Landscape Setting and Land Use

The study area is located at 2900 Crater Lane Newberg, Oregon. The site is surrounded by residential development with Crater Lane forming the western boundary of the study area. An existing house is in the northwestern portion of tax lot 3201; however this area is not part of the study area.

The study area consists of generally flat topography that gently slopes from east to west, with elevations approximately between 210 and 205 feet. Most of the site is regularly mowed and consists of weedy herbaceous upland species. Woody vegetation, including big leaf maple (*Acer macrophyllum*, FACU), beaked hazelnut (*Corylus cornuta*, FACU), plum (*Prunus* sp. (UPL)), English hawthorn (*Crataegus monogyna*, FAC), Oregon ash, (*Fraxinus latifolia*, FACW), and Himalayan blackberry (*Rubus armeniacus*, FAC) are present along the eastern and southern boundaries of the tax lot.

The Natural Resources Conservation Services (NRCS) mapped soils within the study area include Woodburn silt loam, 0 to 3 percent slopes, and Wapato silty clay loam, 0 to 3 percent slopes. Wapato silty clay loam is considered a hydric soil.

B. Site Alterations

The Google Earth historical photos of the study area from 1994 through 2020 show no significant changes within the site. Single-family homes were constructed east of the study area between 1994 and 2000; by 2015, single-family homes surround the study area.

A portion of the study area has been recently disturbed to prepare the site for construction of a residential development; however, based on topography, and sample points within the vicinity of the disturbance, wetlands or waters do not appear to be located within this portion of the study area.

C. Precipitation Data and Analysis

The study area was delineated on July 22 and August 4, 2021; precipitation data for the months preceding these dates are summarized below.

Table 1 compares the most recent monthly precipitation amounts recorded in Newberg (at the Rex 1 S, OR station) to the average monthly precipitation recorded in Newberg, as well as to the normal precipitation range as identified in the Natural Resource Conservation Service’s (NRCS) WETS climate table for the Rex 1 S, OR station.

These data show that when rainfall amounts have varied most significantly from the mean, the amounts may also have fallen outside the normal range of variability for this area. For this period, April 2021 was below the normal range of variation; and May and June 2021 were within the normal range of variation. Data was missing for observed July rainfall; therefore PHS’ was unable to determine whether rainfall is above or below the normal range for that month.

Table 1: Comparison of average and observed monthly precipitation in Newberg, prior to the July/August 2021 delineation fieldwork.

Month	Average Precipitation ¹	30% Chance Will Have		Observed Precipitation ²	Percent of Normal
		Less Than Average ¹	More Than Average ¹		
April*	3.16	2.25	3.74	0.65	21%
May	2.44	1.47	2.96	1.69	69%
June	1.62	0.96	1.97	1.57	97%
July	0.54	0.16	0.59	Missing ³	Unknown ³

- Notes: 1. Source: NRCS WETS Table for Rex 1 S, OR station (<http://agacis.rcc-acis.org>)
 2. Source: NRCS monthly precipitation data (<http://agacis.rcc-acis.org>)
 3. Rainfall data missing/unavailable at the time of this report
 *----Monthly rainfall was below the ‘normal’ range
 **----Monthly rainfall was above the ‘normal’ range

Total observed precipitation for the water year up to month prior to the field work (October 1, 2020, through July 31, 2021) was 33.53 inches, which was approximately 119 percent of the normal for those months. As stated above, the Rex 1 S station is missing data for July and August; the rainfall data below is from the next closest rainfall data station, Newberg 0.3 N, OR.

Table 2: Daily precipitation totals for two weeks prior to and including the day of fieldwork (July 22 and August 4, 2021).

Date	Precipitation (inches)	Date	Precipitation (inches)	Date	Precipitation (inches)	Date	Precipitation (inches)
7-8	0.00	7-15	0.00	7-22	S	7-29	0.00
7-9	0.00	7-16	0.00	7-23	M	7-30	M
7-10	M	7-17	0.00	7-24	M	7-31	0.00
7-11	0.00	7-18	0.00	7-25	M	8-1	0.00
7-12	M	7-19	0.00	7-26	0.00	8-2	0.00
7-13	0.00	7-20	0.00	7-27	0.00	8-3	0.00
7-14	0.00	7-21	0.00	7-28	0.00	8-4	0.00

M = missing data
 S = snow (this data appears to have been entered incorrectly by NOAA)

Precipitation was significantly below normal for the water year before and during the wetland delineation fieldwork; however PHS believes that “normal conditions for this site still prevailed even given the dryer than normal conditions. Since precipitation was below normal in the months leading up to the fieldwork, soils were probed to a depth of 20 inches to ensure that a dry season water table was not present.

D. Methods

PHS conducted the wetland delineation on the site based on the presence of wetland hydrology, hydric soils, and hydrophytic vegetation, in accordance with the Routine On-site Determination, as described in the *Corps of Engineers Wetland Delineation Manual, Wetlands Research Program Technical Report Y-87-1* (“The 1987 Manual”) and the *Regional Supplement to the Corps of Engineers Wetland Delineation Manual: Western Mountains, Valleys, and Coast Region*. PHS conducted the wetland delineation within the study area on July 22 and August 4, 2021.

The entire study area was investigated for the presence of wetlands or other waters. One waters (Tributary A) was delineated within the study area. The OHWM of the tributary was determined using changes in topography and vegetation. Portions of the tributary are vegetated; as such, data was taken the northern portion of the tributary, as it enters the study area. Vegetated areas are less than 10% of the overall channel (data points 3 and 4; Photos D, E, F, H and I).

The vegetation throughout the site generally consists of various facultative or dryer grasses and weedy forbs. PHS took data in areas that are topographically higher than the tributary to verify that no wetlands are present within the study area. The upland areas do not exhibit surface indicators of wetlands (i.e. ponded surface water, geomorphic position, or stunted/stressed vegetation, FACW or wetter vegetation, etc.).

E. Description of all Wetlands and Other Non-Wetland Waters

Tributary A

Tributary A, located in the east-central and southern portion of the study area, is approximately 1,789 square feet (0.04 acre) in size. Tributary A’s Cowardin classification is riverine, lower perennial, permanently flooded (R2UBH); the Hydrogeomorphic (HGM) classification is Riverine.

Tributary A enters the study area via a culvert from underneath Myrtlewood Drive along the eastern study area boundary, flowing west, then south along the boundary of the tax lot. At the time of the delineation, the tributary had flowing water between 2 and 6 inches deep. Tributary A continues offsite to the west, entering a culvert under Crater Lane, and eventually reaches Chehalem Creek downstream.

Dominant vegetation along the banks of the tributary includes willows (*Salix sp* (FAC-FACW), Oregon ash, barnyard grass (*Echinochloa crus-galli*, FAC), English hawthorn, Himalayan blackberry, reed canarygrass (*Phalaris arundinacea*, FACW), and sweet vernal grass (*Anthoxanthum odorata*, FACU). Soils within Tributary A meet the hydric soil criteria for Depleted Matrix (F3) or Redox Dark Surface (F6) (sample point 3).

F. Deviation from Local and/or National Wetland Inventories

The National Wetland Inventory (NWI) does not map wetland or waters within the study area, however, PHS delineated Tributary A within the study area. This discrepancy may be due to land cover as NWI maps are generated primarily on the basis of interpretation of color infrared aerial photographs (scale of 1:58,000), with limited “ground truthing” to confirm the interpretations..

There is no Local Wetland Inventory for Newberg.

G. Mapping Method

PHS flagged the limits of the wetlands within the study area with blue pin flags; lime green tape was used for sample point locations. Wetlands and sample points were then surveyed by PHS using a Trimble Geo7x GPS unit with submeter accuracy.

H. Additional Information

None.

I. Results and Conclusions

PHS delineated Tributary A within the study area. The total area of waters within the study area boundary is 1,789 square feet (0.04 acre). The Cowardin and HGM classifications are stated in Section E.

J. Required Disclaimer

This report documents the investigation, best professional judgment and conclusions of the investigators. It is correct and complete to the best of our knowledge. It should be considered a Preliminary Jurisdictional Determination of wetlands and other waters and used at your own risk unless it has been reviewed and approved in writing by the Oregon Department of State Lands in accordance with OAR 141-090-0005 through 141-090-0055.

III. REFERENCES

- Adamus, P.R. and D. Field. 2001 *Guidebook for Hydrogeomorphic (HGM)-based Assessment of Oregon Wetland and Riparian Sites. Willamette Valley Ecoregion, Riverine Impounding and Slopes/Flats Subclasses*. Oregon Division of State Lands, Salem, OR.
- GoogleEarth Map, 2021. Aerial photograph, August 2020.
- Lichvar, R.W., D.L. Banks, W.N. Kirchner, and N.C. Melvin. State of Oregon 2018 Plant List. The National Wetland Plant List: 2018 Wetland Ratings
http://wetland-plants.usace.army.mil/nwpl_static/v34/home/home.html#
- Munsell Color, 2009. *Munsell Soil Color Charts*. Gretag-Macbeth, New Windsor, New York.
- Natural Resources Conservation Services (NRCS) WETS table for Rex 1 S, Newberg, OR.
<http://agacis.rcc-acis.org/?fips=41071>
- Oregon Department of State Lands, 2009. Oregon Revised Statutes (ORS), *Chapter 196 — Columbia River Gorge; Ocean Resource Planning; Wetlands; Removal and Fill*. Section 196.800 Definitions for ORS 196.600 - 196.905
- Oregon Maps online, 2021. <http://www.ormap.org/>
- US Army Corps of Engineers, Environmental Laboratory, 1987. *Corps of Engineers Wetland Delineation Manual. Technical Report Y-87-1*.
- US Army Corps of Engineers, Environmental Laboratory, 2010. *Regional Supplement to the Corps of Engineers Wetland Delineation Manual: Western Mountains, Valleys, and Coast Region (Version 2.0)*.
- USDA, Web Soil Mapper, 2021. *Soil Survey of Yamhill County, Oregon*.
<http://websoilsurvey.nrcs.usda.gov/app/WebSoilSurvey.aspx>
- US Geologic Survey, 2020. *7.5-minute topographic map, Newberg Oregon quadrangle*.
<https://viewer.nationalmap.gov/basic/?basemap=b1&category=ustopo&title=US%20Topo%20Download>

Appendix A

Figures



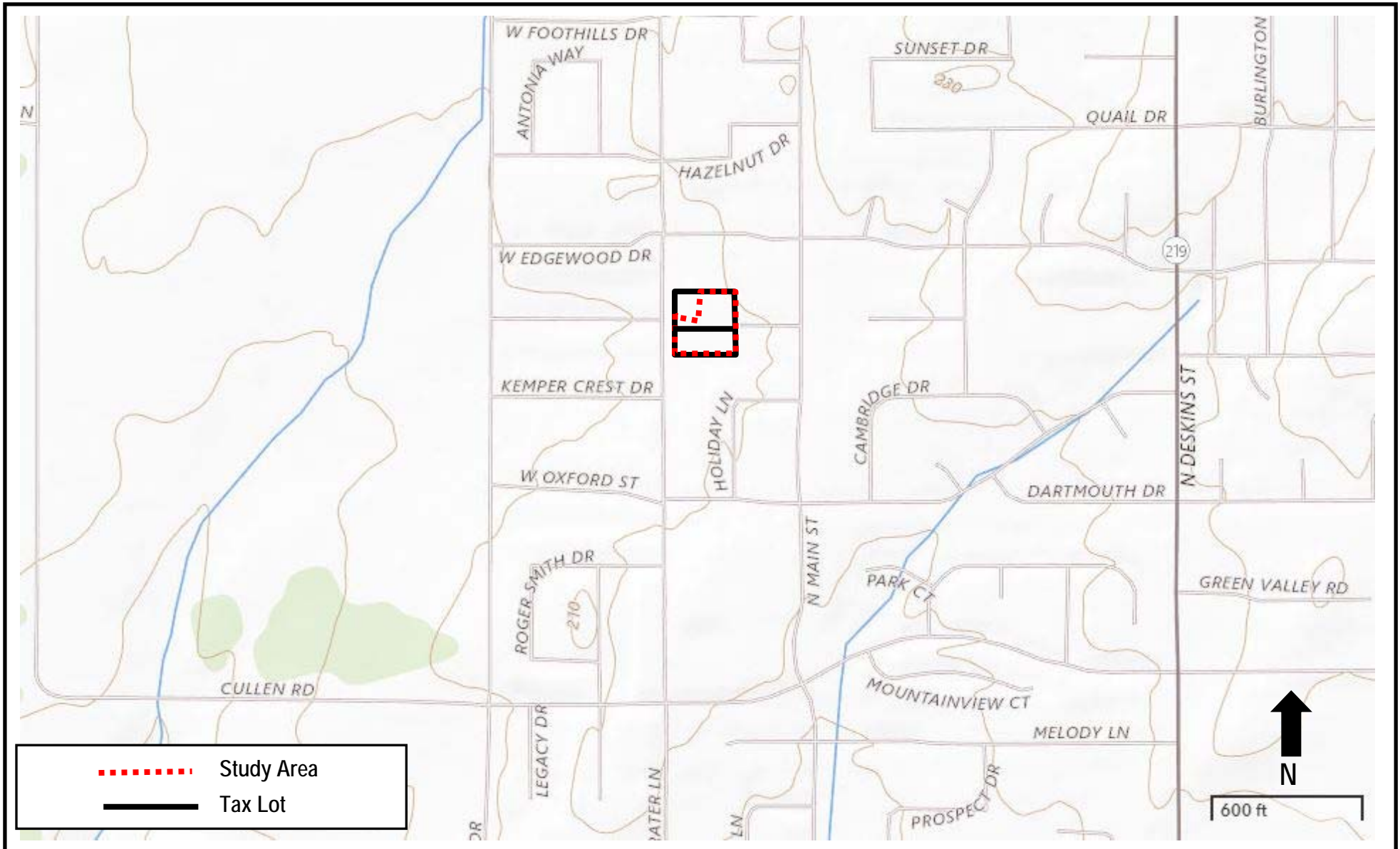

Project# 7299
Date 8/9/21



Pacific Habitat Services, Inc.
9450 SW Commerce Circle, Suite 180
Wilsonville, OR 97070

General Location and Topography
2900 Crater Lane, Newberg, Oregon
United States Geological Survey (USGS) Newberg, Oregon 7.5 quadrangle, 2020
(viewer.nationalmap.gov/basic)

FIGURE
1



ASSESSMENT & TAX
CARTOGRAPHY
SECTION 7 T.3S. R.2W. W.M.
YAMHILL COUNTY OREGON
1" = 400'

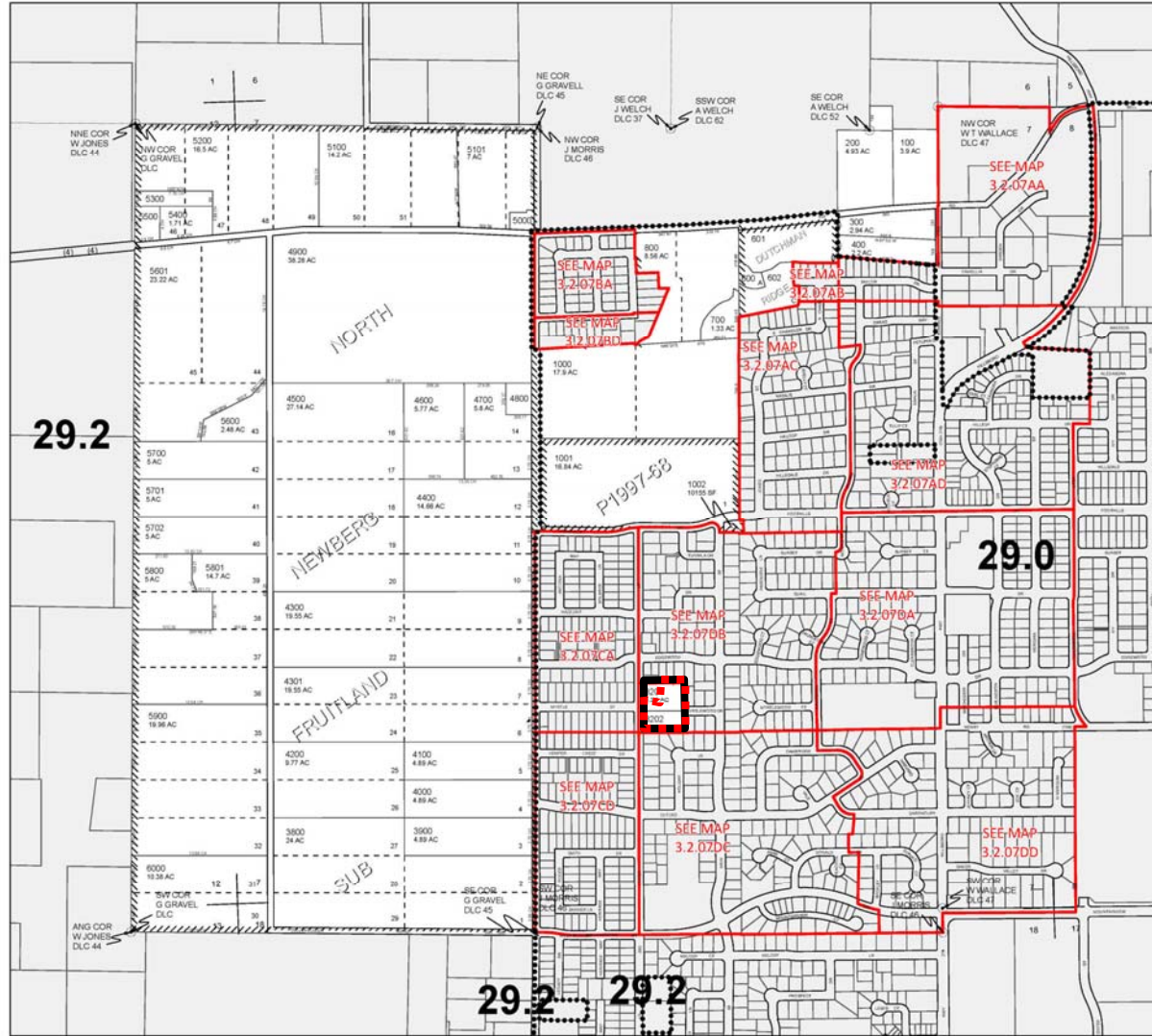

CANCELLED TAXLOTS:

3704	1801
3703	1800
3702	1700
3701	1600
3700	1500
3600	1400
3500	1300
3400	1200
3300	1100
3203	1003
3200	1000
3100	500
3002	
3001	
3000	
2900	
2800	
2700	
2600	
2503	
2502	
2501	
2500	
2400	
2300	
2200	
2100	
2000	
1901	
1900	

DATE PRINTED: 2/11/2020

This product is for Assessment and Taxation (A&T) purposes only and has not been prepared or is suitable for legal, engineering, surveying or any purposes other than assessment and taxation.



290 ft

- - - - - - Study Area
 - Tax Lot

Project# 7299
Date 8/9/21



Pacific Habitat Services, Inc.
9450 SW Commerce Circle, Suite 180
Wilsonville, OR 97070

Tax Lot Map
2900 Crater Lane, Newberg, Oregon
The Oregon Map (ormap.net)

FIGURE
2

Wetlands



August 10, 2021

Wetlands

- | | | |
|--|---|--|
|  Estuarine and Marine Deepwater |  Freshwater Emergent Wetland |  Lake |
|  Estuarine and Marine Wetland |  Freshwater Forested/Shrub Wetland |  Other |
| |  Freshwater Pond |  Riverine |

This map is for general reference only. The US Fish and Wildlife Service is not responsible for the accuracy or currentness of the base data shown on this map. All wetlands related data should be used in accordance with the layer metadata found on the Wetlands Mapper web site.

National Wetlands Inventory (NWI)
This page was produced by the NWI mapper

Project# 7299
Date 8/9/21



Pacific Habitat Services, Inc.
9450 SW Commerce Circle, Suite 180
Wilsonville, OR 97070

National Wetland Inventory
2900 Crater Lane, Newberg, Oregon
<https://www.fws.gov/wetlands/data/mapper.html>

FIGURE
3

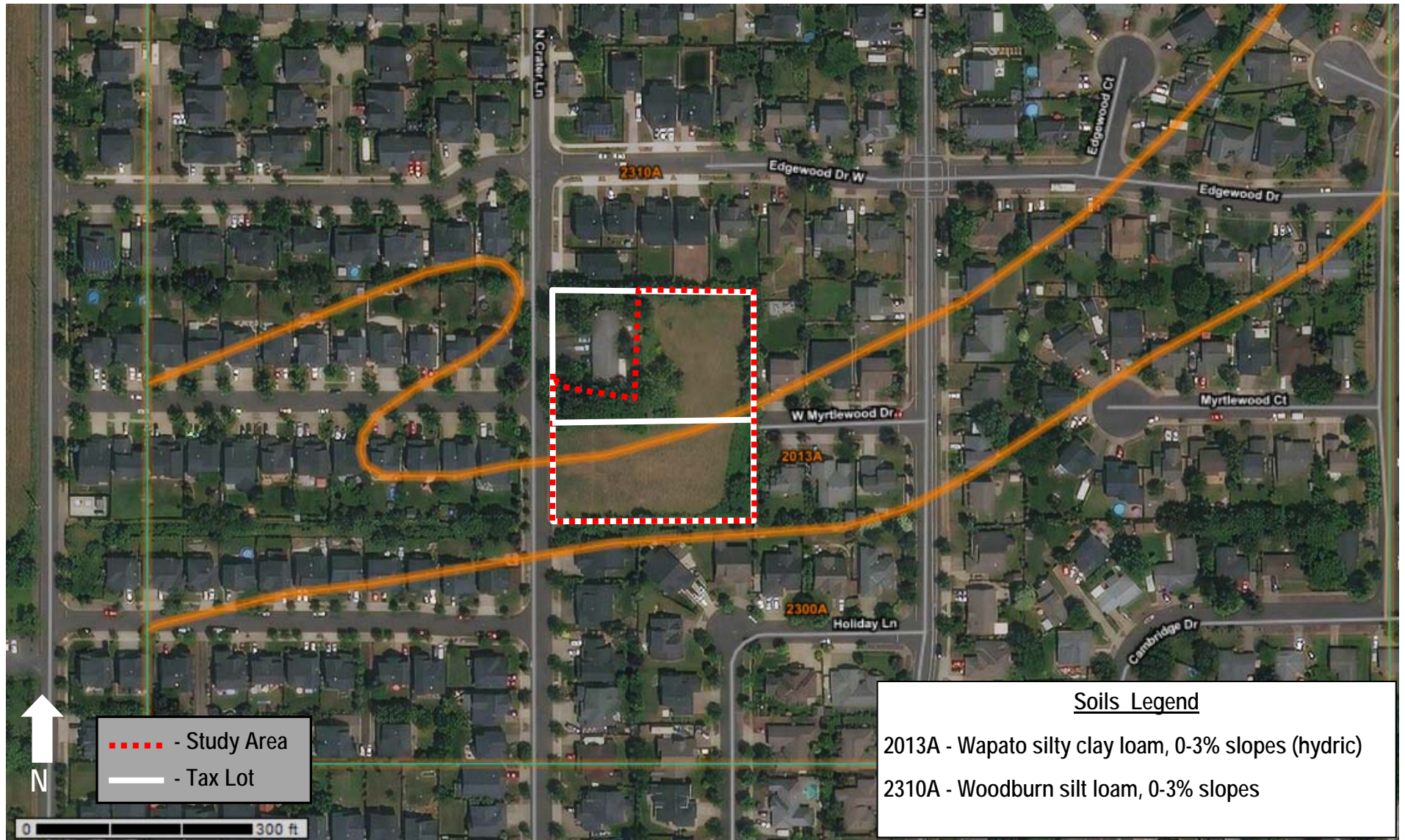

Project # 7299
 Date 8/9/21



Pacific Habitat Services, Inc.
 9450 SW Commerce Circle, Suite 180
 Wilsonville, OR 97070

Soils
 2900 Crater Lane, Newberg, Oregon
 Natural Resources Conservation Services, Web Soil Survey, 2021
 (websoilsurvey.sc.egov.usda.gov)

FIGURE
 4

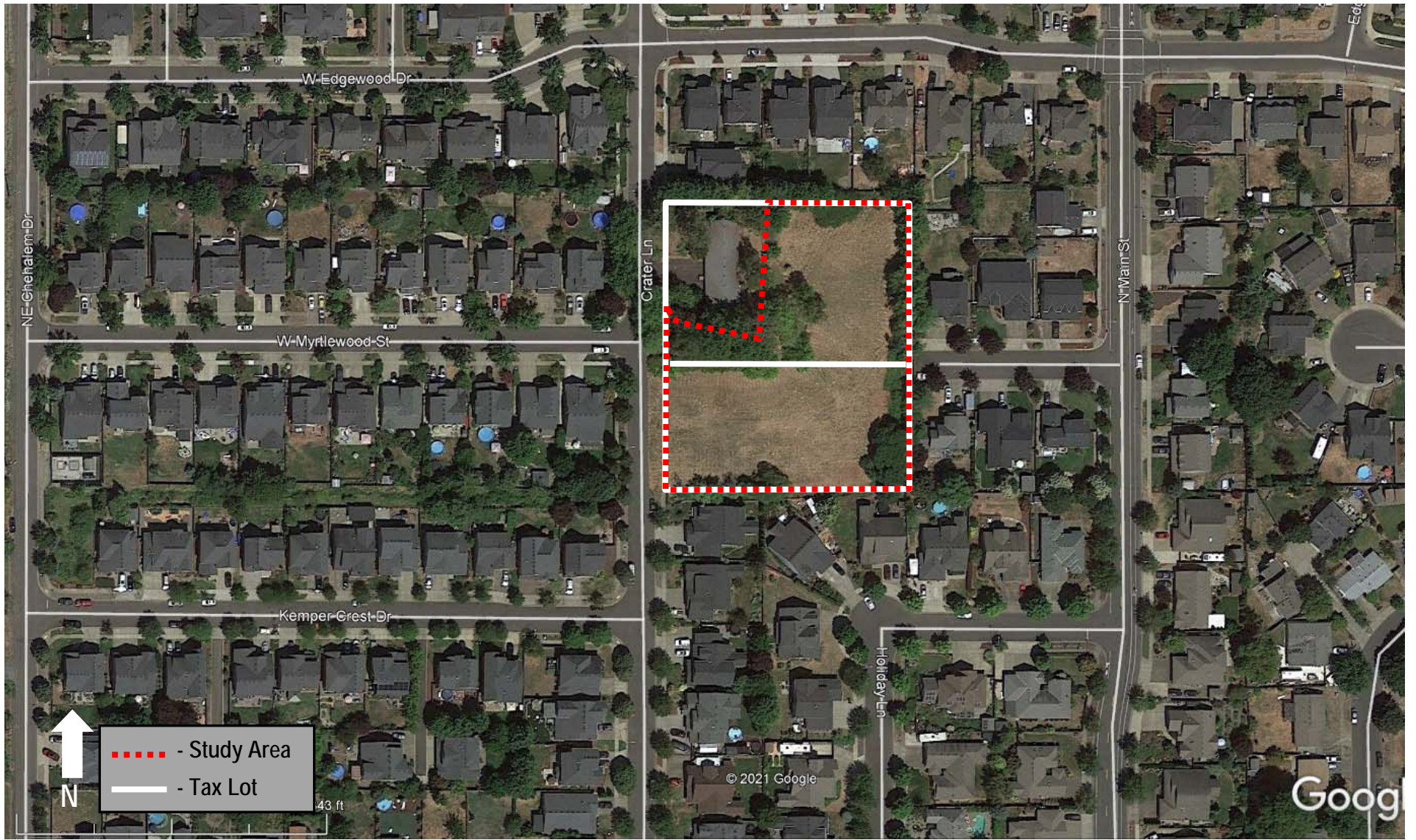

Project# 7299
Date 8/9/21



Pacific Habitat Services, Inc.
9450 SW Commerce Circle, Suite 180
Wilsonville, OR 97070





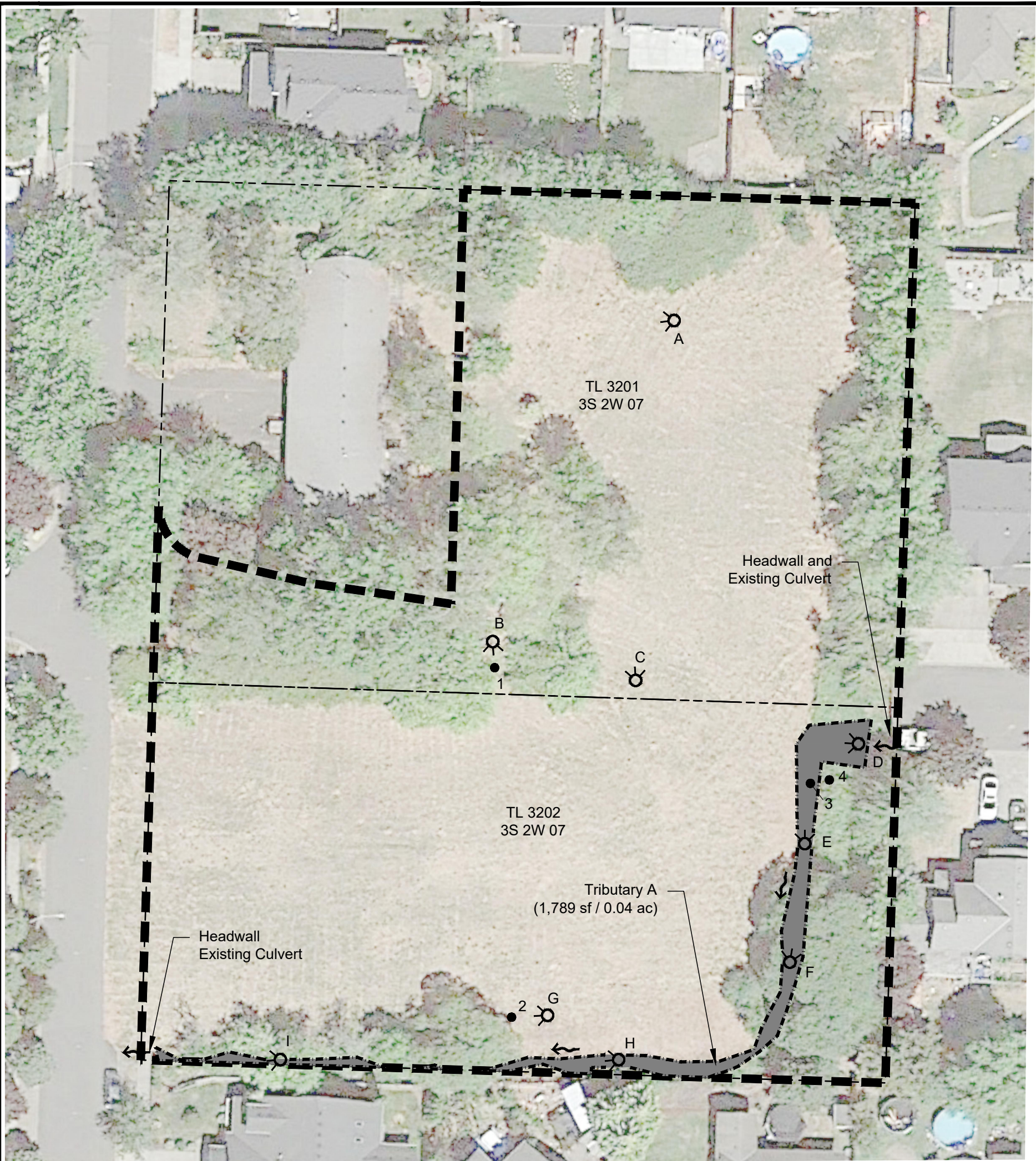

Aerial Photo
2900 Crater Lane, Newberg, Oregon
GoogleEarth, 2021

FIGURE

5



LEGEND

-  Study Area Boundary (76,190 sf / 1.75 ac)
-  Waters of the State/US (1,789 sf / 0.04 ac)
-  Ordinary High Water (OHW)
-  Direction of Flow
-  Sample Point
-  Photo Point
-  Tax Lot Line

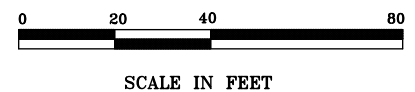
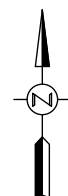

Tributary and sample points were surveyed using a Trimble Geo7x GPS unit; accuracy is sub-meter.



Wetland Delineation
 2900 Crater Lane - Newberg, Oregon

FIGURE
6

8-12-2021

Appendix B

Wetland Determination Data Sheets



WETLAND DETERMINATION DATA FORM - Western Mountains, Valleys, and Coast Region

Project/Site: 2900 Crater Lane City/County: Newberg/Yamhill Sampling Date: 7/22/2021
 Applicant/Owner: Greenwing Companies State: OR Sampling Point: 1
 Investigator(s): MS Section, Township, Range: S7, T3S, R2W
 Landform (hillslope, terrace, etc.): Flat Local relief (concave, convex, none): None Slope (%): 1
 Subregion (LRR): LRR A Lat: 45.3211 Long: -122.9805 Datum: WGS84
 Soil Map Unit Name: Woodburn silt loam, 0 to 3 percent slopes NWI Classification: None
 Are climatic/hydrologic conditions on the site typical for this time of year? Yes No X (if no, explain in Remarks)
 Are vegetation Soil or Hydrology significantly disturbed? Are "Normal Circumstances" present? (Y/N) Y
 Are vegetation Soil or Hydrology naturally problematic? If needed, explain any answers in Remarks.)

SUMMARY OF FINDINGS – Attach site map showing sampling point locations, transects, important features, etc.

Hydrophytic Vegetation Present?	Yes <u>X</u>	No <u> </u>	Is Sampled Area within a Wetland?	Yes <u> </u>	No <u>X</u>
Hydric Soil Present?	Yes <u> </u>	No <u>X</u>			
Wetland Hydrology Present?	Yes <u> </u>	No <u>X</u>			

Remarks:
Precipitation significantly below normal for water year.

VEGETATION - Use scientific names of plants.

	absolute % cover	Dominant Species?	Indicator Status	Dominance Test worksheet:	
Tree Stratum (plot size: <u> </u>)				Number of Dominant Species	
1	<u> </u>	<u> </u>	<u> </u>	That are OBL, FACW, or FAC: <u>2</u> (A)	
2	<u> </u>	<u> </u>	<u> </u>	Total Number of Dominant	
3	<u> </u>	<u> </u>	<u> </u>	Species Across All Strata: <u>3</u> (B)	
4	<u> </u>	<u> </u>	<u> </u>	Percent of Dominant Species	
	<u>0</u>	= Total Cover		That are OBL, FACW, or FAC: <u>67%</u> (A/B)	
Sapling/Shrub Stratum (plot size: <u>15</u>)				Prevalence Index Worksheet:	
1	<u>40</u>	<u>X</u>	<u>FAC</u>	Total % Cover of <u> </u> Multiply by:	
2	<u>5</u>	<u> </u>	<u>FACW</u>	OBL Species	<u> </u> x 1 = <u>0</u>
3	<u>5</u>	<u> </u>	<u>(UPL)</u>	FACW species	<u> </u> x 2 = <u>0</u>
4	<u>1</u>	<u> </u>	<u>FAC</u>	FAC Species	<u> </u> x 3 = <u>0</u>
5	<u> </u>	<u> </u>	<u> </u>	FACU Species	<u> </u> x 4 = <u>0</u>
	<u>51</u>	= Total Cover		UPL Species	<u> </u> x 5 = <u>0</u>
Herb Stratum (plot size: <u>5</u>)				Column Totals	<u>0</u> (A) <u>0</u> (B)
1	<u>30</u>	<u>X</u>	<u>FAC</u>	Prevalence Index =B/A = <u>#DIV/0!</u>	
2	<u>10</u>	<u>X</u>	<u>(UPL)</u>	Hydrophytic Vegetation Indicators:	
3	<u>1</u>	<u> </u>	<u>FACU</u>	1- Rapid Test for Hydrophytic Vegetation	
4	<u> </u>	<u> </u>	<u> </u>	<u>X</u> 2- Dominance Test is >50%	
5	<u> </u>	<u> </u>	<u> </u>	3-Prevalence Index is ≤ 3.0 ¹	
6	<u> </u>	<u> </u>	<u> </u>	4-Morphological Adaptations ¹ (provide supporting	
7	<u> </u>	<u> </u>	<u> </u>	data in Remarks or on a separate sheet)	
8	<u> </u>	<u> </u>	<u> </u>	5- Wetland Non-Vascular Plants ¹	
	<u>41</u>	= Total Cover		Problematic Hydrophytic Vegetation ¹ (Explain)	
Woody Vine Stratum (plot size: <u> </u>)				¹ Indicators of hydric soil and wetland hydrology must be present, unless	
1	<u> </u>	<u> </u>	<u> </u>	disturbed or problematic.	
2	<u> </u>	<u> </u>	<u> </u>	Hydrophytic	
	<u>0</u>	= Total Cover		Vegetation Present? Yes <u>X</u> No <u> </u>	
% Bare Ground in Herb Stratum <u> </u>					

Remarks:

Profile Description: (Describe to the depth needed to document the indicator or confirm the absence of indicators.)

Table with columns: Depth (Inches), Matrix (Color (moist), %), Redox Features (Color (moist), %, Type, Loc), Texture, Remarks. Row 1: 0-12, 10YR 3/2, 100, Silt Loam.

1Type: C=Concentration, D=Depletion, RM=Reduced Matrix, CS=Covered or Coated Sand Grains.

2Location: PL=Pore Lining, M=Matrix.

Hydric Soil Indicators: (Applicable to all LRRs, unless otherwise noted.)

Indicators for Problematic Hydric Soils3:

Table listing hydric soil indicators (Histosol, Histic Epipedon, etc.) and problematic hydric soil indicators (2 cm Muck, Red Parent Material, etc.) with checkboxes.

3Indicators of hydrophytic vegetation and wetland hydrology must be present, unless disturbed or problematic.

Restrictive Layer (if present):

Type: _____
Depth (inches): _____

Hydric Soil Present? Yes _____ No X

Remarks:

HYDROLOGY

Wetland Hydrology Indicators:

Primary Indicators (minimum of one required; check all that apply)

Secondary Indicators (2 or more required)

Table listing primary and secondary wetland hydrology indicators (Surface Water, High Water Table, etc.) with checkboxes.

Field Observations:

Surface Water Present? Yes _____ No X
Water Table Present? Yes _____ No X
Saturation Present? Yes _____ No X
Depth (inches): >12

Wetland Hydrology Present? Yes _____ No X

Describe Recorded Data (stream gauge, monitoring well, aerial photos, previous inspections), if available:

Remarks:

WETLAND DETERMINATION DATA FORM - Western Mountains, Valleys, and Coast Region

Project/Site: 2900 Crater Lane City/County: Newberg/Yamhill Sampling Date: 7/22/2021
 Applicant/Owner: Greenwing Companies State: OR Sampling Point: 2
 Investigator(s): MS Section, Township, Range: S7, T3S, R2W
 Landform (hillslope, terrace, etc.): Flat Local relief (concave, convex, none): None Slope (%): 1
 Subregion (LRR): LRR A Lat: 45.3207 Long: -122.9805 Datum: WGS84
 Soil Map Unit Name: Wapato silty clay loam NWI Classification: None
 Are climatic/hydrologic conditions on the site typical for this time of year? Yes No X (if no, explain in Remarks)
 Are vegetation Soil or Hydrology significantly disturbed? Are "Normal Circumstances" present? (Y/N) Y
 Are vegetation Soil or Hydrology naturally problematic? If needed, explain any answers in Remarks.)

SUMMARY OF FINDINGS – Attach site map showing sampling point locations, transects, important features, etc.

Hydrophytic Vegetation Present?	Yes <u> </u>	No <u>X</u>	Is Sampled Area within a Wetland?	Yes <u> </u>	No <u>X</u>
Hydric Soil Present?	Yes <u>X</u>	No <u> </u>			
Wetland Hydrology Present?	Yes <u> </u>	No <u>X</u>			

Remarks:
Precipitation significantly below normal for water year.

VEGETATION - Use scientific names of plants.

	absolute % cover	Dominant Species?	Indicator Status	Dominance Test worksheet:	
Tree Stratum (plot size: <u> </u>)				Number of Dominant Species	
1	<u> </u>	<u> </u>	<u> </u>	That are OBL, FACW, or FAC: <u>2</u> (A)	
2	<u> </u>	<u> </u>	<u> </u>	Total Number of Dominant	
3	<u> </u>	<u> </u>	<u> </u>	Species Across All Strata: <u>4</u> (B)	
4	<u> </u>	<u> </u>	<u> </u>	Percent of Dominant Species	
	<u>0</u>	= Total Cover		That are OBL, FACW, or FAC: <u>50%</u> (A/B)	
Sapling/Shrub Stratum (plot size: <u>15</u>)				Prevalence Index Worksheet:	
1	<u>40</u>	<u>X</u>	<u>FAC</u>	Total % Cover of	Multiply by:
2	<u> </u>	<u> </u>	<u> </u>	OBL Species	x 1 = <u>0</u>
3	<u> </u>	<u> </u>	<u> </u>	FACW species	x 2 = <u>0</u>
4	<u> </u>	<u> </u>	<u> </u>	FAC Species	x 3 = <u>210</u>
5	<u> </u>	<u> </u>	<u> </u>	FACU Species	x 4 = <u>280</u>
	<u>40</u>	= Total Cover		UPL Species	x 5 = <u>0</u>
Herb Stratum (plot size: <u>5</u>)				Column Totals	<u>140</u> (A) <u>490</u> (B)
1	<u>45</u>	<u>X</u>	<u>FACU</u>	Prevalence Index =B/A = <u>3.50</u>	
2	<u>30</u>	<u>X</u>	<u>FAC</u>	Hydrophytic Vegetation Indicators:	
3	<u>20</u>	<u>X</u>	<u>FACU</u>	1- Rapid Test for Hydrophytic Vegetation	
4	<u>5</u>	<u> </u>	<u>FACU</u>	2- Dominance Test is >50%	
5	<u> </u>	<u> </u>	<u> </u>	3-Prevalence Index is ≤ 3.0 ¹	
6	<u> </u>	<u> </u>	<u> </u>	4-Morphological Adaptations ¹ (provide supporting	
7	<u> </u>	<u> </u>	<u> </u>	data in Remarks or on a separate sheet)	
8	<u> </u>	<u> </u>	<u> </u>	5- Wetland Non-Vascular Plants ¹	
	<u>100</u>	= Total Cover		Problematic Hydrophytic Vegetation ¹ (Explain)	
Woody Vine Stratum (plot size: <u> </u>)				¹ Indicators of hydric soil and wetland hydrology must be present, unless	
1	<u> </u>	<u> </u>	<u> </u>	disturbed or problematic.	
2	<u> </u>	<u> </u>	<u> </u>	Hydrophytic	
	<u>0</u>	= Total Cover		Vegetation	
% Bare Ground in Herb Stratum <u> </u>				Yes <u> </u> No <u>X</u>	
Remarks:				Present?	

Remarks:

Profile Description: (Describe to the depth needed to document the indicator or confirm the absence of indicators.)

Table with columns: Depth (Inches), Matrix (Color (moist), %), Redox Features (Color (moist), %, Type, Loc), Texture, Remarks. Rows include 0-3, 3-8, and 8-12 inch depths.

1Type: C=Concentration, D=Depletion, RM=Reduced Matrix, CS=Covered or Coated Sand Grains.

2Location: PL=Pore Lining, M=Matrix.

Hydric Soil Indicators: (Applicable to all LRRs, unless otherwise noted.)

Indicators for Problematic Hydric Soils3:

Table listing hydric soil indicators such as Histosol (A1), Sandy Redox (S5), and indicators for problematic hydric soils like 2 cm Muck (A10) and Red Parent Material (TF2).

3Indicators of hydrophytic vegetation and wetland hydrology must be present, unless disturbed or problematic.

Restrictive Layer (if present):

Type: _____
Depth (inches): _____

Hydric Soil Present? Yes X No

Remarks:

HYDROLOGY

Wetland Hydrology Indicators:

Primary Indicators (minimum of one required; check all that apply)

Secondary Indicators (2 or more required)

Table listing primary and secondary wetland hydrology indicators such as Surface Water (A1), High Water Table (A2), Water stained Leaves (B9), and others.

Field Observations:

Surface Water Present? Yes No X
Water Table Present? Yes No X
Saturation Present? Yes No X

Wetland Hydrology Present? Yes No X

Describe Recorded Data (stream gauge, monitoring well, aerial photos, previous inspections), if available:

Remarks:

Probed to >20 inches - no moisture.

WETLAND DETERMINATION DATA FORM - Western Mountains, Valleys, and Coast Region

Project/Site: 2900 Crater Lane City/County: Newberg/Yamhill Sampling Date: 8/4/2021
 Applicant/Owner: Greenwing Companies State: OR Sampling Point: 3
 Investigator(s): MS Section, Township, Range: S7, T3S, R2W
 Landform (hillslope, terrace, etc.): Ditch Local relief (concave, convex, none): Concave Slope (%): 1
 Subregion (LRR): LRR A Lat: 45.3209 Long: -122.9800 Datum: WGS84
 Soil Map Unit Name: Wapato silty clay loam NWI Classification: None
 Are climatic/hydrologic conditions on the site typical for this time of year? Yes No X (if no, explain in Remarks)
 Are vegetation Soil or Hydrology significantly disturbed? Are "Normal Circumstances" present? (Y/N) Y
 Are vegetation Soil or Hydrology naturally problematic? If needed, explain any answers in Remarks.)

SUMMARY OF FINDINGS – Attach site map showing sampling point locations, transects, important features, etc.

Hydrophytic Vegetation Present?	Yes <u>X</u>	No <u> </u>	Is Sampled Area within a Wetland?	Yes <u> </u>	No <u>X</u>
Hydric Soil Present?	Yes <u>X</u>	No <u> </u>			
Wetland Hydrology Present?	Yes <u>X</u>	No <u> </u>			

Remarks:
Precipitation significantly below normal for water year.
Although this area meets wetland criteria, it is below the OHWM of the tributary. Vegetation is <10% of the channel area, and is considered waters.

VEGETATION - Use scientific names of plants.

	absolute % cover	Dominant Species?	Indicator Status	Dominance Test worksheet:	
Tree Stratum (plot size: <u> </u>)				Number of Dominant Species	
1	<u> </u>	<u> </u>	<u> </u>	That are OBL, FACW, or FAC: <u>2</u> (A)	
2	<u> </u>	<u> </u>	<u> </u>	Total Number of Dominant	
3	<u> </u>	<u> </u>	<u> </u>	Species Across All Strata: <u>2</u> (B)	
4	<u> </u>	<u> </u>	<u> </u>	Percent of Dominant Species	
	<u>0</u>	= Total Cover		That are OBL, FACW, or FAC: <u>100%</u> (A/B)	
Sapling/Shrub Stratum (plot size: <u>5</u>)				Prevalence Index Worksheet:	
1	<u>3</u>	<u> </u>	<u>FAC</u>	Total % Cover of <u> </u> Multiply by:	
2	<u> </u>	<u> </u>	<u> </u>	OBL Species <u> </u> x 1 = <u>0</u>	
3	<u> </u>	<u> </u>	<u> </u>	FACW species <u> </u> x 2 = <u>0</u>	
4	<u> </u>	<u> </u>	<u> </u>	FAC Species <u> </u> x 3 = <u>0</u>	
5	<u> </u>	<u> </u>	<u> </u>	FACU Species <u> </u> x 4 = <u>0</u>	
	<u>3</u>	= Total Cover		UPL Species <u> </u> x 5 = <u>0</u>	
Herb Stratum (plot size: <u>5</u>)				Column Totals <u>0</u> (A) <u>0</u> (B)	
1	<u>45</u>	<u>X</u>	<u>FAC</u>	Prevalence Index =B/A = <u>#DIV/0!</u>	
2	<u>30</u>	<u>X</u>	<u>FAC</u>	Hydrophytic Vegetation Indicators:	
3	<u>20</u>	<u> </u>	<u>(OBL)</u>	<u> </u> 1- Rapid Test for Hydrophytic Vegetation	
4	<u>5</u>	<u> </u>	<u>FAC</u>	<u>X</u> 2- Dominance Test is >50%	
5	<u>10</u>	<u> </u>	<u>OBL</u>	<u> </u> 3-Prevalence Index is ≤ 3.0 ¹	
6	<u>10</u>	<u> </u>	<u>FACW</u>	<u> </u> 4-Morphological Adaptations ¹ (provide supporting	
7	<u> </u>	<u> </u>	<u> </u>	data in Remarks or on a separate sheet)	
8	<u> </u>	<u> </u>	<u> </u>	<u> </u> 5- Wetland Non-Vascular Plants ¹	
	<u>120</u>	= Total Cover		<u> </u> Problematic Hydrophytic Vegetation ¹ (Explain)	
Woody Vine Stratum (plot size: <u> </u>)				¹ Indicators of hydric soil and wetland hydrology must be present, unless	
1	<u> </u>	<u> </u>	<u> </u>	disturbed or problematic.	
2	<u> </u>	<u> </u>	<u> </u>	Hydrophytic	
	<u>0</u>	= Total Cover		Vegetation Present? Yes <u>X</u> No <u> </u>	
% Bare Ground in Herb Stratum <u> </u>					
Remarks:					

Profile Description: (Describe to the depth needed to document the indicator or confirm the absence of indicators.)

Depth (Inches)	Matrix		Redox Features				Texture	Remarks
	Color (moist)	%	Color (moist)	%	Type ¹	Loc ²		
0-2	10YR 3/2	100					Silt Loam	
2-5	10YR 2/2	100			C	M	Sandy Loam	
5-8	10YR 3/1	90	10YR 3/6	10	C	M	Silty Clay Loam	Medium
8-15	N3/	80	7.5YR 4/6	20	C	M, PL	Silty Clay Loam	Coarse

¹Type: C=Concentration, D=Depletion, RM=Reduced Matrix, CS=Covered or Coated Sand Grains. ²Location: PL=Pore Lining, M=Matrix.

Hydric Soil Indicators: (Applicable to all LRRs, unless otherwise noted.)		Indicators for Problematic Hydric Soils ³ :	
<input type="checkbox"/> Histosol (A1)	<input type="checkbox"/> Sandy Redox (S5)	<input type="checkbox"/> 2 cm Muck (A10)	
<input type="checkbox"/> Histic Epipedon (A2)	<input type="checkbox"/> Stripped Matrix (S6)	<input type="checkbox"/> Red Parent Material (TF2)	
<input type="checkbox"/> Black Histic (A3)	<input type="checkbox"/> Loamy Mucky Mineral (F1) (except MLRA 1)	<input type="checkbox"/> Very Shallow Dark Surface (TF12)	
<input type="checkbox"/> Hydrogen Sulfide (A4)	<input type="checkbox"/> Loamy Gleyed Matrix (F2)	<input type="checkbox"/> Other (explain in Remarks)	
<input type="checkbox"/> Depleted Below Dark Surface (A11)	<input checked="" type="checkbox"/> Depleted Matrix (F3)		
<input type="checkbox"/> Thick Dark Surface (A12)	<input checked="" type="checkbox"/> Redox Dark Surface (F6)		
<input type="checkbox"/> Sandy Mucky Mineral (S1)	<input type="checkbox"/> Depleted Dark Surface (F7)		³ Indicators of hydrophytic vegetation and wetland hydrology must be present, unless disturbed or problematic.
<input type="checkbox"/> Sandy Gleyed Matrix (S4)	<input type="checkbox"/> Redox Depressions (F8)		

Restrictive Layer (if present):

Type: _____

Depth (inches): _____

Hydric Soil Present? Yes No

Remarks:
Probed to >20 inches - no moisture.

HYDROLOGY

Wetland Hydrology Indicators:

Primary Indicators (minimum of one required; check all that apply)		Secondary Indicators (2 or more required)	
<input checked="" type="checkbox"/> Surface Water (A1)	<input type="checkbox"/> Water stained Leaves (B9) (Except MLRA 1, 2, 4A, and 4B)	<input type="checkbox"/> Water stained Leaves (B9) (MLRA1, 2, 4A, and 4B)	
<input checked="" type="checkbox"/> High Water Table (A2)	<input type="checkbox"/> Salt Crust (B11)	<input type="checkbox"/> Drainage Patterns (B10)	
<input checked="" type="checkbox"/> Saturation (A3)	<input type="checkbox"/> Aquatic Invertebrates (B13)	<input type="checkbox"/> Dry-Season Water Table (C2)	
<input type="checkbox"/> Water Marks (B1)	<input type="checkbox"/> Hydrogen Sulfide Odor (C1)	<input type="checkbox"/> Saturation Visible on Aerial Imagery (C9)	
<input type="checkbox"/> Sediment Deposits (B2)	<input checked="" type="checkbox"/> Oxidized Rhizospheres along Living Roots (C3)	<input checked="" type="checkbox"/> Geomorphic Position (D2)	
<input type="checkbox"/> Drift Deposits (B3)	<input type="checkbox"/> Presence of Reduced Iron (C4)	<input type="checkbox"/> Shallow Aquitard (D3)	
<input type="checkbox"/> Algal Mat or Crust (B4)	<input type="checkbox"/> Recent Iron Reduction in Plowed Soils (C6)	<input checked="" type="checkbox"/> Fac-Neutral Test (D5)	
<input type="checkbox"/> Iron Deposits (B5)	<input type="checkbox"/> Stunted or Stressed Plants (D1) (LRR A)	<input type="checkbox"/> Raised Ant Mounds (D6) (LRR A)	
<input type="checkbox"/> Surface Soil Cracks (B6)	<input type="checkbox"/> Other (Explain in Remarks)	<input type="checkbox"/> Frost-Heave Hummocks (D7)	
<input type="checkbox"/> Inundation Visible on Aerial Imagery (B7)			
<input type="checkbox"/> Sparsely Vegetated Concave Surface (B8)			

Field Observations:

Surface Water Present? Yes No Depth (inches): 2

Water Table Present? Yes No Depth (inches): 4

Saturation Present? Yes No Depth (inches): 0
(includes capillary fringe)

Wetland Hydrology Present? Yes No

Describe Recorded Data (stream gauge, monitoring well, aerial photos, previous inspections), if available:

Remarks:
Approximately 2" of surface water was present within 5' of the sample point.

WETLAND DETERMINATION DATA FORM - Western Mountains, Valleys, and Coast Region

Project/Site: 2900 Crater Lane City/County: Newberg/Yamhill Sampling Date: 8/4/2021
 Applicant/Owner: Greenwing Companies State: OR Sampling Point: 4
 Investigator(s): MS Section, Township, Range: S7, T3S, R2W
 Landform (hillslope, terrace, etc.): Flat Local relief (concave, convex, none): None Slope (%): 0
 Subregion (LRR): LRR A Lat: 45.3210 Long: -122.9800 Datum: WGS84
 Soil Map Unit Name: Wapato silty clay loam NWI Classification: None
 Are climatic/hydrologic conditions on the site typical for this time of year? Yes No X (if no, explain in Remarks)
 Are vegetation Soil or Hydrology significantly disturbed? Are "Normal Circumstances" present? (Y/N) Y
 Are vegetation Soil or Hydrology naturally problematic? If needed, explain any answers in Remarks.)

SUMMARY OF FINDINGS – Attach site map showing sampling point locations, transects, important features, etc.

Hydrophytic Vegetation Present? Yes <u>X</u> No <u> </u>	Is Sampled Area within a Wetland? Yes <u> </u> No <u>X</u>
Hydric Soil Present? Yes <u> </u> No <u>X</u>	
Wetland Hydrology Present? Yes <u> </u> No <u>X</u>	

Remarks:
Precipitation significantly below normal for water year.

VEGETATION - Use scientific names of plants.

Tree Stratum (plot size: <u>30</u>)	absolute % cover	Dominant Species?	Indicator Status	Dominance Test worksheet: Number of Dominant Species That are OBL, FACW, or FAC: <u>3</u> (A) Total Number of Dominant Species Across All Strata: <u>4</u> (B) Percent of Dominant Species That are OBL, FACW, or FAC: <u>75%</u> (A/B)
1 <u>Cedrus deodara</u>	<u>20</u>	<u>X</u>	<u>(UPL)</u>	
2 <u> </u>	<u> </u>	<u> </u>	<u> </u>	
3 <u> </u>	<u> </u>	<u> </u>	<u> </u>	
4 <u> </u>	<u> </u>	<u> </u>	<u> </u>	
5 <u> </u>	<u>20</u>	= Total Cover		
Sapling/Shrub Stratum (plot size: <u>15</u>)	absolute % cover	Dominant Species?	Indicator Status	Hydrophytic Vegetation Indicators: <u> </u> 1- Rapid Test for Hydrophytic Vegetation <u>X</u> 2- Dominance Test is >50% <u> </u> 3-Prevalence Index is ≤ 3.0 ¹ <u> </u> 4-Morphological Adaptations ¹ (provide supporting data in Remarks or on a separate sheet) <u> </u> 5- Wetland Non-Vascular Plants ¹ <u> </u> Problematic Hydrophytic Vegetation ¹ (Explain) ¹ Indicators of hydric soil and wetland hydrology must be present, unless disturbed or problematic. Hydrophytic Vegetation Present? Yes <u>X</u> No <u> </u>
1 <u>Rubus armeniacus</u>	<u>70</u>	<u>X</u>	<u>FAC</u>	
2 <u> </u>	<u> </u>	<u> </u>	<u> </u>	
3 <u> </u>	<u> </u>	<u> </u>	<u> </u>	
4 <u> </u>	<u> </u>	<u> </u>	<u> </u>	
5 <u> </u>	<u>70</u>	= Total Cover		
Herb Stratum (plot size: <u>5</u>)	absolute % cover	Dominant Species?	Indicator Status	% Bare Ground in Herb Stratum <u> </u>
1 <u>Juncus effusus</u>	<u>45</u>	<u>X</u>	<u>FACW</u>	
2 <u>Echinochloa crus-galli</u>	<u>30</u>	<u>X</u>	<u>FAC</u>	
3 <u> </u>	<u> </u>	<u> </u>	<u> </u>	
4 <u> </u>	<u> </u>	<u> </u>	<u> </u>	
5 <u> </u>	<u> </u>	<u> </u>	<u> </u>	
6 <u> </u>	<u> </u>	<u> </u>	<u> </u>	
7 <u> </u>	<u>75</u>	= Total Cover		
Woody Vine Stratum (plot size: <u> </u>)	absolute % cover	Dominant Species?	Indicator Status	Remarks:
1 <u> </u>	<u> </u>	<u> </u>	<u> </u>	
2 <u> </u>	<u>0</u>	= Total Cover		

Profile Description: (Describe to the depth needed to document the indicator or confirm the absence of indicators.)

Depth (Inches)	Matrix		Redox Features				Texture	Remarks
	Color (moist)	%	Color (moist)	%	Type ¹	Loc ²		
0-3	7.5YR 3/2	100					Silt Loam	
3-8	10YR 4/2	95	10YR 5/6	5	C	M	Silty Clay Loam	
8-12	10YR 4/2	85	10YR 5/6	15	C	M	Silty Clay Loam	

¹Type: C=Concentration, D=Depletion, RM=Reduced Matrix, CS=Covered or Coated Sand Grains. ²Location: PL=Pore Lining, M=Matrix.

Hydric Soil Indicators: (Applicable to all LRRs, unless otherwise noted.)		Indicators for Problematic Hydric Soils ³ :	
<input type="checkbox"/> Histosol (A1)	<input type="checkbox"/> Sandy Redox (S5)	<input type="checkbox"/> 2 cm Muck (A10)	
<input type="checkbox"/> Histic Epipedon (A2)	<input type="checkbox"/> Stripped Matrix (S6)	<input type="checkbox"/> Red Parent Material (TF2)	
<input type="checkbox"/> Black Histic (A3)	<input type="checkbox"/> Loamy Mucky Mineral (F1) (except MLRA 1)	<input type="checkbox"/> Very Shallow Dark Surface (TF12)	
<input type="checkbox"/> Hydrogen Sulfide (A4)	<input type="checkbox"/> Loamy Gleyed Matrix (F2)	<input type="checkbox"/> Other (explain in Remarks)	
<input type="checkbox"/> Depleted Below Dark Surface (A11)	<input checked="" type="checkbox"/> Depleted Matrix (F3)		
<input type="checkbox"/> Thick Dark Surface (A12)	<input type="checkbox"/> Redox Dark Surface (F6)		
<input type="checkbox"/> Sandy Mucky Mineral (S1)	<input type="checkbox"/> Depleted Dark Surface (F7)		³ Indicators of hydrophytic vegetation and wetland hydrology must be present, unless disturbed or problematic.
<input type="checkbox"/> Sandy Gleyed Matrix (S4)	<input type="checkbox"/> Redox Depressions (F8)		

Restrictive Layer (if present):		
Type: _____		
Depth (inches): _____		Hydric Soil Present? Yes <input checked="" type="checkbox"/> No <input type="checkbox"/>
Remarks: _____		

HYDROLOGY

Wetland Hydrology Indicators:	
Primary Indicators (minimum of one required; check all that apply)	Secondary Indicators (2 or more required)
<input type="checkbox"/> Surface Water (A1)	<input type="checkbox"/> Water stained Leaves (B9) (Except MLRA 1, 2, 4A, and 4B)
<input type="checkbox"/> High Water Table (A2)	<input type="checkbox"/> Water stained Leaves (B9) (MLRA1, 2, 4A, and 4B)
<input type="checkbox"/> Saturation (A3)	<input type="checkbox"/> Salt Crust (B11)
<input type="checkbox"/> Water Marks (B1)	<input type="checkbox"/> Aquatic Invertebrates (B13)
<input type="checkbox"/> Sediment Deposits (B2)	<input type="checkbox"/> Hydrogen Sulfide Odor (C1)
<input type="checkbox"/> Drift Deposits (B3)	<input type="checkbox"/> Oxidized Rhizospheres along Living Roots (C3)
<input type="checkbox"/> Algal Mat or Crust (B4)	<input type="checkbox"/> Presence of Reduced Iron (C4)
<input type="checkbox"/> Iron Deposits (B5)	<input type="checkbox"/> Recent Iron Reduction in Plowed Soils (C6)
<input type="checkbox"/> Surface Soil Cracks (B6)	<input type="checkbox"/> Stunted or Stressed Plants (D1) (LRR A)
<input type="checkbox"/> Inundation Visible on Aerial Imagery (B7)	<input type="checkbox"/> Other (Explain in Remarks)
<input type="checkbox"/> Sparsely Vegetated Concave Surface (B8)	<input type="checkbox"/> Drainage Patterns (B10)
	<input type="checkbox"/> Dry-Season Water Table (C2)
	<input type="checkbox"/> Saturation Visible on Aerial Imagery (C9)
	<input type="checkbox"/> Geomorphic Position (D2)
	<input type="checkbox"/> Shallow Aquitard (D3)
	<input type="checkbox"/> Fac-Neutral Test (D5)
	<input type="checkbox"/> Raised Ant Mounds (D6) (LRR A)
	<input type="checkbox"/> Frost-Heave Hummocks (D7)

Field Observations:		
Surface Water Present? Yes <input type="checkbox"/> No <input checked="" type="checkbox"/>	Depth (inches): _____	Wetland Hydrology Present? Yes _____ No <input checked="" type="checkbox"/>
Water Table Present? Yes <input type="checkbox"/> No <input checked="" type="checkbox"/>	Depth (inches): <u>>12</u>	
Saturation Present? Yes <input type="checkbox"/> No <input checked="" type="checkbox"/> (includes capillary fringe)	Depth (inches): <u>>12</u>	

Describe Recorded Data (stream gauge, monitoring well, aerial photos, previous inspections), if available: _____

Remarks: **Probed to >20 inches - no moisture.**

Appendix C

Site Photos





Photo A:

Looking west at north-central portion of site.

Photo B:

Looking south at sample point 1, in central portion of site.



Project # 7299

Date 8/10/21



Pacific Habitat Services, Inc.
9450 SW Commerce Circle, Suite 180
Wilsonville, OR 97070

Photo documentation

2900 Crater Lane, Newberg, Oregon

Photos taken July 22, 2021



Photo C:

Looking north at the central portion of the site.

Photo D:

Looking west at Tributary A as it enters the study area.



Project # 7299
Date 8/10/21



Pacific Habitat Services, Inc.
9450 SW Commerce Circle, Suite 180
Wilsonville, OR 97070

Photo documentation
2900 Crater Lane, Newberg, Oregon
Photos taken July 22, 2021



Photo E:

Looking north at the northeastern portion of Tributary A.

Photo F

Looking north at the central-eastern portion of Tributary A.



Project # 7299,
8/10/21



Pacific Habitat Services, Inc.
9450 SW Commerce Circle, Suite 180
Wilsonville, OR 97070

Photo documentation
2900 Crater Lane, Newberg, Oregon
Photos taken July 22, 2021



Photo G:

Looking west at sample point 2., in southern portion of site.

Photo H:

Looking west at the southwestern portion of Tributary A.



Project 7299
Date 8/10/21



Pacific Habitat Services, Inc.
9450 SW Commerce Circle, Suite 180
Wilsonville, OR 97070

Photo documentation
2900 Crater Lane, Newberg, Oregon
Photos taken July 22, 2021



Photo I:

Looking west at the western portion of Tributary A.

Project # 7299
Date 8/10/21



Pacific Habitat Services, Inc.
9450 SW Commerce Circle, Suite 180
Wilsonville, OR 97070

Photo documentation
2900 Crater Lane, Newberg, Oregon
Photos taken July 22, 2021

Appendix D

Wetland Definitions and Methodology



WATERS OF THE STATE AND WETLAND DEFINITION AND CRITERIA

Regulatory Jurisdiction

Wetlands and water resources in Oregon are regulated by the Oregon Department of State Lands (DSL) under the Removal-Fill Law (ORS 196.800-196.990) and by the U.S. Army Corps of Engineers (COE) through Section 404 of the Clean Water Act.

The primary source documents for wetland delineations within Oregon is the *Corps of Engineers Wetlands Delineation Manual, Technical Report Y-87-1* (Environmental Laboratory 1987) and the *Regional Supplement to the Corps of Engineers Wetland Delineation Manual: Western Mountains, Valleys, and Coast Region (Version 2.0)* (U.S. Army Corps of Engineers, 2010), which are required by both DSL and COE.

Waters of This State and Wetland Definition

Waters of This State are defined as “all natural waterways, tidal and non-tidal bays, intermittent streams, constantly flowing streams, lakes, wetlands, that portion of the Pacific Ocean that is in the boundaries of this state, all other navigable and non-navigable bodies of water in this state and those portions of the ocean shore, as defined in ORS 390.605, where removal or fill activities are regulated under a state-assumed permit program as provided in 33 U.S.C. 1344(g) of the Federal Water Pollution Control Act, as amended.” (DSL 2014)

Wetlands are defined as “those areas that are inundated or saturated by surface or ground water at a frequency and duration sufficient to support, and that under normal circumstances do support, a prevalence of vegetation typically adapted for life in saturated soil conditions” (DSL 2014).

Wetland Criteria

Based on the above definition, three major factors characterize a wetland: hydrology, substrate, and biota.

Wetland Hydrology

Wetland hydrology is related to duration of saturation, frequency of saturation, and critical depth of saturation. The 1987 manual defines wetland hydrology as inundation or saturation within a major portion of the root zone (usually above 12 inches), typically for at least 12.5% of the growing season. The wetland hydrology criterion can be met, however, if saturation within the major portion of the root zone is present for only 5% of the growing season, depending on other evidence.

The growing season is defined as the portion of the year when soil temperatures at 12.0 inches below the soil surface are higher than biological zero (41 degrees Fahrenheit, 5 degrees Celsius), but also allows approximation from frost free days, based on air temperature. The growing season for any given site or location is determined from US Natural Resources Conservation Service, (formerly Soil Conservation Service) data and information.

Wetland hydrologic indicators include the following: visual observation of inundation or saturation, watermarks, drift lines, sediment deposits, and/or oxidized rhizospheres with living roots. Oxidized rhizospheres are defined as yellowish-red zones around the roots and rhizomes of some plants that grow in frequently saturated soils. Other indicators of hydrology, including algal mats or crust, iron deposits, surface soil cracks, sparsely vegetated concave surface, salt crust, aquatic invertebrates, hydrogen sulfide odor, reduced iron, iron reduction in tilled soils, and stunted or stressed plants can also be used to determine the presence of wetland hydrology.

Wetland Substrate (Soils)

Most wetlands are characterized by hydric soils. Hydric soils are those that are ponded, flooded, or saturated for long enough during the growing season to develop anaerobic conditions. Periodic saturation of soils causes alternation of reduced and oxidized conditions, which leads to the formation of redoximorphic features (gleying and mottling). Mineral hydric soils will be either gleyed or will have bright mottles and/or low matrix chroma. The redoximorphic feature known as gley is a result of greatly reduced soil conditions, which result in a characteristic grayish, bluish or greenish soil color. The term mottling is used to describe areas of contrasting color within a soil matrix. The soil matrix is the portion of the soil layer that has the predominant color. Soils that have brightly colored mottles and a low matrix chroma are indicative of a fluctuating water table.

Hydric soil indicators include organic content of greater than 50% by volume, and/or presence of redoximorphic features and dark soil matrix, as determined by the use of a Munsell Soil Color Chart. This chart establishes the chroma, value and hue of soils based on comparison with color chips. Mineral hydric soil must meet one of the 16 definitions for hydric soil indicators, or be classified as a “problem soil” in the Regional Supplement.

Wetland Biota (Vegetation)

Wetland biota is defined as hydrophytic vegetation. A hydrophyte is a plant species that is capable of growing in substrates that are periodically deficient in oxygen as a result of saturated soil conditions. The U.S. Fish and Wildlife Service, in the *National List of Plant Species that Occur in Wetlands*, has established five basic groups of vegetation based on their frequency of occurrence in wetlands. These categories, referred to as the "wetland indicator status", are as follows: obligate wetland plants (OBL), facultative wetland (FACW), facultative (FAC), facultative upland (FACU), and obligate upland (UPL). Table 1 gives a definition of the plant indicator codes.

Table 1. Description of Wetland Plant Indicator Status Codes

Indicator Code	Status
OBL	Obligate wetland. Plants that always occur in standing water or in saturated soils.
FACW	Facultative wetland. Plants that nearly always occur in areas of prolonged flooding or require standing water or saturated soils but may, on rare occasions, occur in non-wetlands.
FAC	Facultative. Plants that occur in a variety of habitats, including wetland and mesic to xeric non-wetland habitats but commonly occur in standing water or saturated soils.
FACU	Facultative upland. Plants that typically occur in xeric or mesic non-wetland habitats but may frequently occur in standing water or saturated soils.
UPL	Obligate upland. Plants that rarely occur in water or saturated soils.

Observations of hydrology, soils, and vegetation, were made using the "Routine On-site" delineation method as defined in the 1987 manual and the Regional Supplement for areas that were not currently in agricultural production. One-foot diameter soil pits were excavated to 20 inches and soil profiles were examined for hydric soil and wetland hydrology field indicators. In addition, a visual absolute-cover estimate of the dominant species of the plant community was performed using soil pit locations as a center of reference. Dominant plant species are based on estimates of absolute cover for herbaceous, and shrub species within a 5 foot radius of the sample point, and basal area cover for tree and woody vine species within a 30 foot radius of the sample point. Plant species in each vegetative layer, which are estimated at less than 20% of the total cover, are not considered to be dominant. The wetland indicator status is then used to determine if there is an overall dominance (greater than 50%) of wetland or upland plant species. If less than 50% of the dominant species are hydrophytic, then the prevalence index may be used to determine if the subdominant species are hydrophytic. If the prevalence index is less than or equal to 3, hydrophytic vegetation criterion is met.

During data collection, the soil profiles were examined for hydric soil and wetland hydrology field indicators. Plant species and cover were recorded. Data was recorded on standard data sheets, which contain the information specified in the 1987 Corps Manual and the Regional Supplement.