

Technical Memorandum

February 9, 2024

Project# 28544

To: Brett Musick, PE
City of Newberg
414 E 1st St
Newberg, OR 97132

From: Caleb Cox, PE, Tony Roos, PE, Wade Scarbrough, PE, Matthew Hagen

RE: N Main Street at Illinois Street Intersection Study – Existing Conditions

INTRODUCTION

The City of Newberg has commenced a project to enhance safety and operational performance at the intersection of N Main Street and Illinois Street. This memorandum evaluates the existing conditions at the project intersection as well as several key intersections and road segments within the project influence area.

INTERSECTION CONTEXT

The intersection of N Main Street and E Illinois Street is located adjacent to Highway (Hwy) 240 with the southern leg of the intersection providing a short connection to the Highway 240 and N Main Street intersection. These two intersections operate as one intersection due to their proximity to each other.

Highway 240 serves traffic connecting Highway 99W and Newberg to the towns of Yamhill, Carlton, and Gaston. Figure 1 below shows the project intersection area.



Figure 1. Project Location (Image source: Google Earth)

TRANSPORTATION SYSTEM OVERVIEW

The intersection of N Main Street and Illinois Street serves both local and regional traffic, and any modifications to the traffic pattern will need to be understood within the context of the surrounding transportation network. Therefore, this study evaluates conditions at several key intersections including:

- N Main Street and E Columbia Drive
- N Main Street and E Pinehurst Drive
- N College Street (Hwy 219) and E Pinehurst Drive
- N College Street (Hwy 219) and Deskins Street
- N College Street (Hwy 219) and E Illinois Street
- Deskins Street and E Illinois Street
- N Washington Street and E Illinois Street
- N Main Street and E Illinois Street
- N Main Street (Hwy 240) and W Illinois Street (Hwy 240)
- N Main Street (Hwy 240) and E North Street

As displayed in figure 2, all the study intersections are unsignalized, with stop signs controlling traffic movements on one or more approaches. The N Main Street / E Illinois Street intersection has stop controlled approaches for southbound N Main Street and westbound E Illinois Street while the northwest approach is uncontrolled. The intersection of N Main Street and W Illinois Street (Hwy 240) has stop control on the southbound approach, while the northbound and westbound (Hwy 240) approaches are uncontrolled.

Table 1 below shows the study area's roadway characteristics.

Table 1. Project Area Roadway Characteristics

Roadway	Lanes	Facility's Jurisdiction	Function Classification ¹	Speed Limit	Sidewalk Presence	Bicycle Facility Presence	On-Street Parking
N Main Street	2	City of Newberg	Major Collector	25	Partial	No	Partial
E Illinois Street	2	City of Newberg	Major Collector	25	Partial	No	Yes
E Columbia Drive	2	City of Newberg	Minor Collector	25 ²	Partial	No	Yes
E Pinehurst Drive	2	City of Newberg	Local / Residential	25	Yes	No	Yes
N College Street (Hwy 219)	2	ODOT	Minor Arterial	25-35	Partial	Partial	Partial
Deskins Street	2	City of Newberg	Local / Residential	25 ²	Partial	Partial	Partial
N Washington Street	2	City of Newberg	Local / Residential	25 ²	Yes	No	Yes
Hwy 240 (W Illinois Street and N Main Street)	2	ODOT	Minor Arterial	25	Yes	Partial	No
E North Street	2	City of Newberg	Local / Residential	25 ²	Yes	No	Yes

¹City of Newberg Functional Classification Map, Transportation System Plan (Reference 1)

²Assumed speed limit based on functional classification of the roadway.

H:\28544 - N Main at Illinois Intersection Study\report\figs\28544_Existing Conditions.dwg Feb 08, 2024 - 9:36am - mhagen Layout Tab: Existing LC-TC

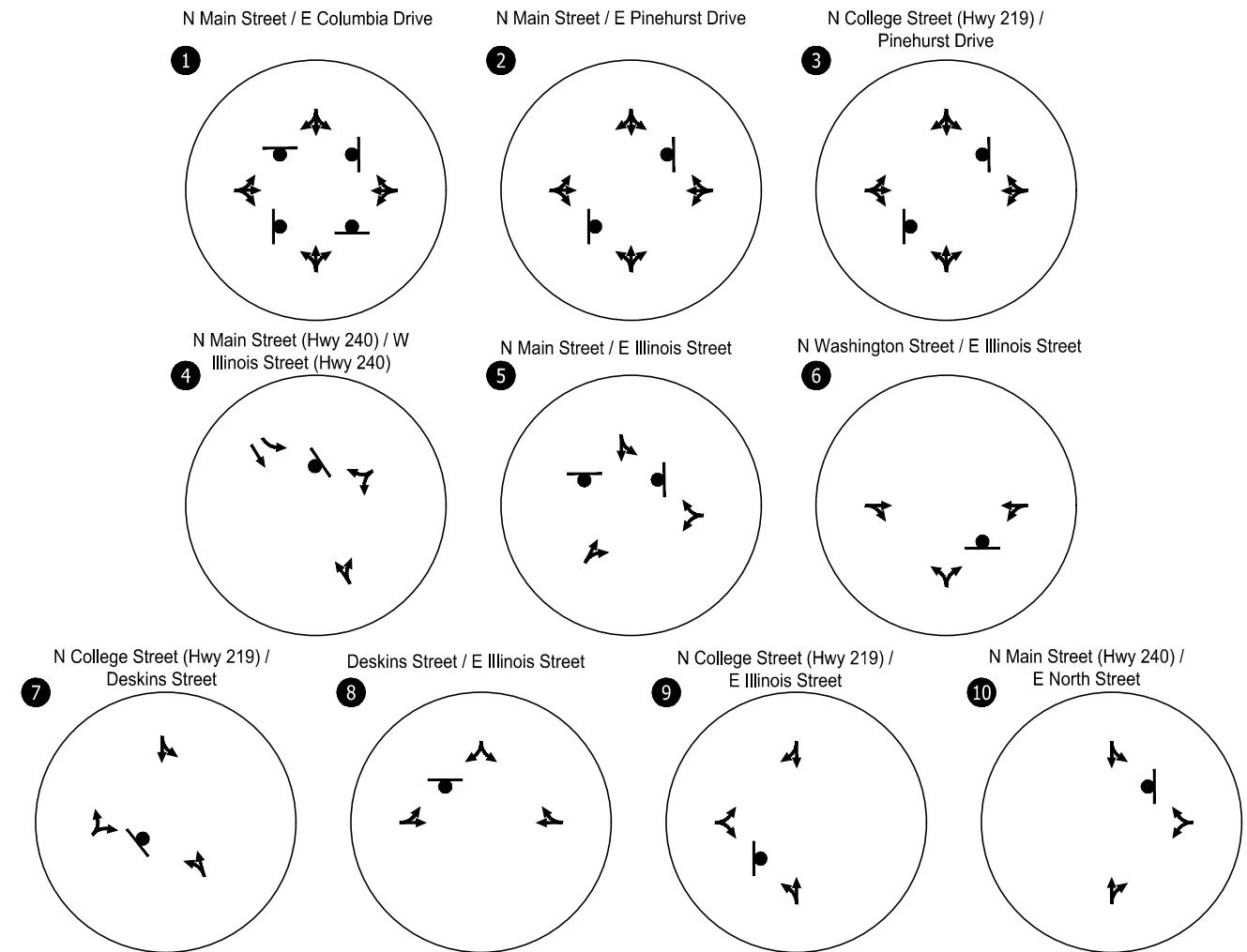

Stop Sign

Existing Year 2023 Lane Configuration and Traffic Control Devices
Newberg, OR

Figure 2

EXISTING CONDITIONS EVALUATION

This section analyzes the existing conditions of the study area, including vehicular operations, pedestrian and bicycle facilities, crash data, and safety analysis.

TRAFFIC VOLUMES

Vehicular turning volume counts were collected at nine of the study intersections in September 2023 during the weekday morning (7:00-9:00 AM) and evening (4:00-6:00 PM) peak periods:

Figure 3 and Figure 4 show the existing year 2023 volumes for the weekday AM and PM peak hours respectively.

Additionally, traffic count data was collected during the Saturday midday (11:00 AM-1:00 PM) time period at four study intersections to understand potential traffic impacts from sporting events at Jaquith park located on N Main Street. Saturday counts at the four study intersections and are shown in Figure 5.

Daily traffic volumes were also collected for the four legs of the project intersection in September 2023. The intersection leg volumes are summarized in Table 2 below for a typical mid-week day (Tuesday-Thursday).

Table 2. Daily Traffic Volumes

Project Intersection Leg	Bi-Directional Traffic Volume
N Main Street (btwn E Clifford Court and E Illinois Street)	2,331
N Main Street (Hwy 240) (btwn W Illinois Street and E North Street)	11,603
E Illinois Street (btwn N Main Street and N Washington Street)	2,539
W Illinois Street (Hwy 240) (btwn N Grant Street and N Main Street)	10,346

Attachment "A" contains the collected traffic counts.

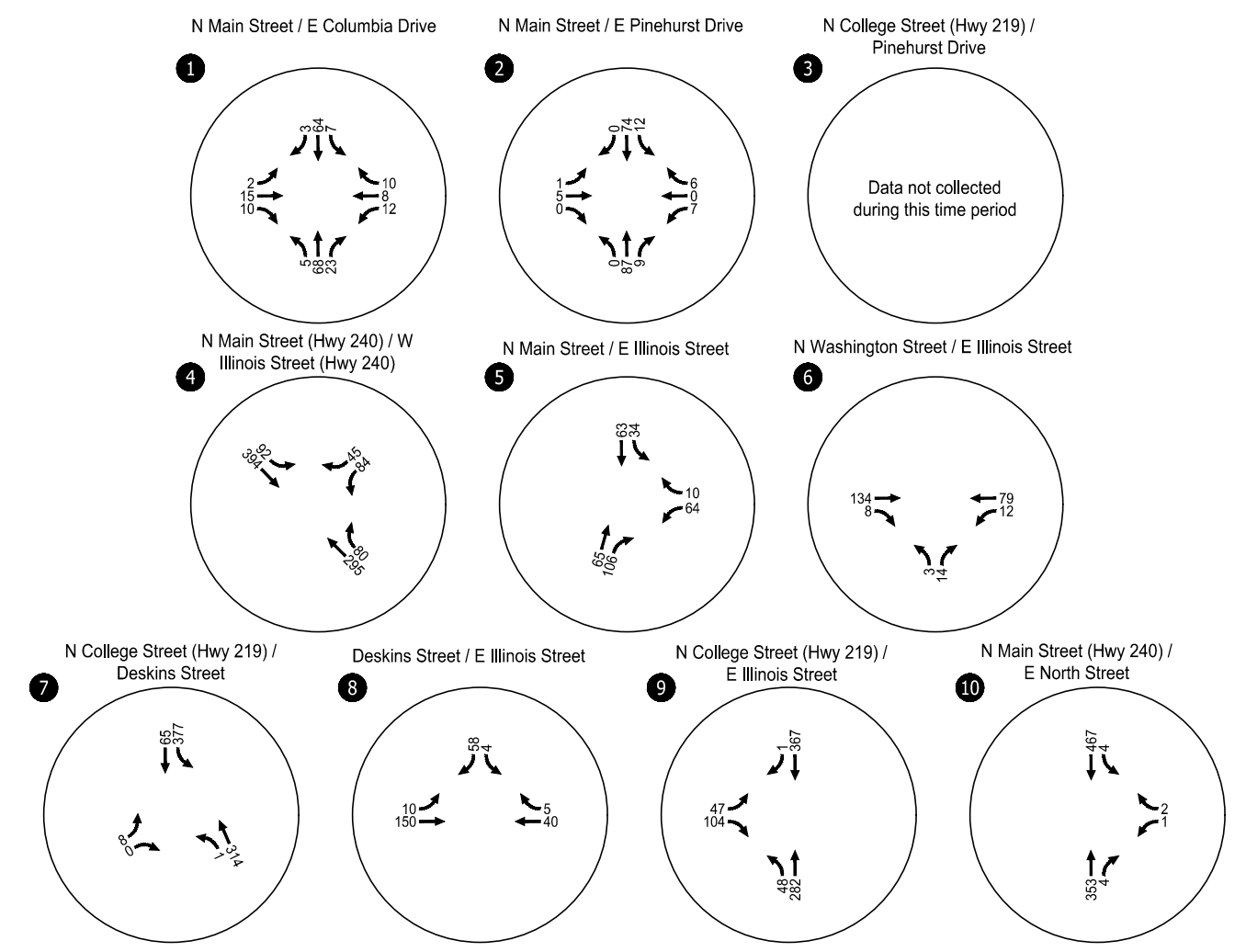
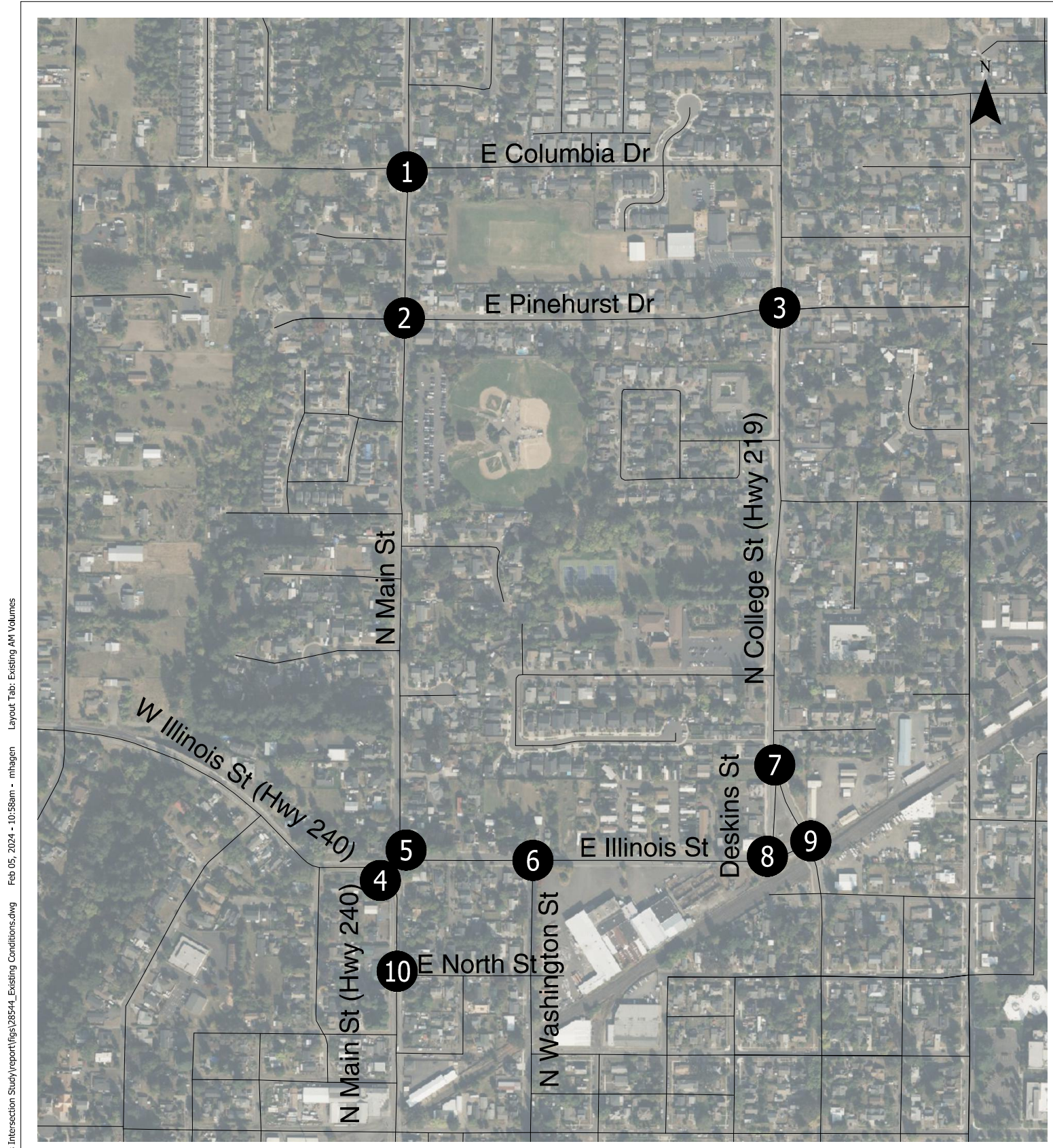

Existing Year 2023 Traffic Volumes
AM Peak Hour
Newberg, OR

Figure
3

H:\28544 - N Main at Illinois Intersection Study\report\figs\28544_Existing Conditions.dwg Feb 05, 2024 - 10:58am - mhaagen Layout Tab: Existing AM Volumes

H:\28544 - N Main at Illinois Intersection Study\report\figs\28544_Existing Conditions.dwg Feb 05, 2024 - 11:00am - mhagen Layout Tab: Existing PM Volumes

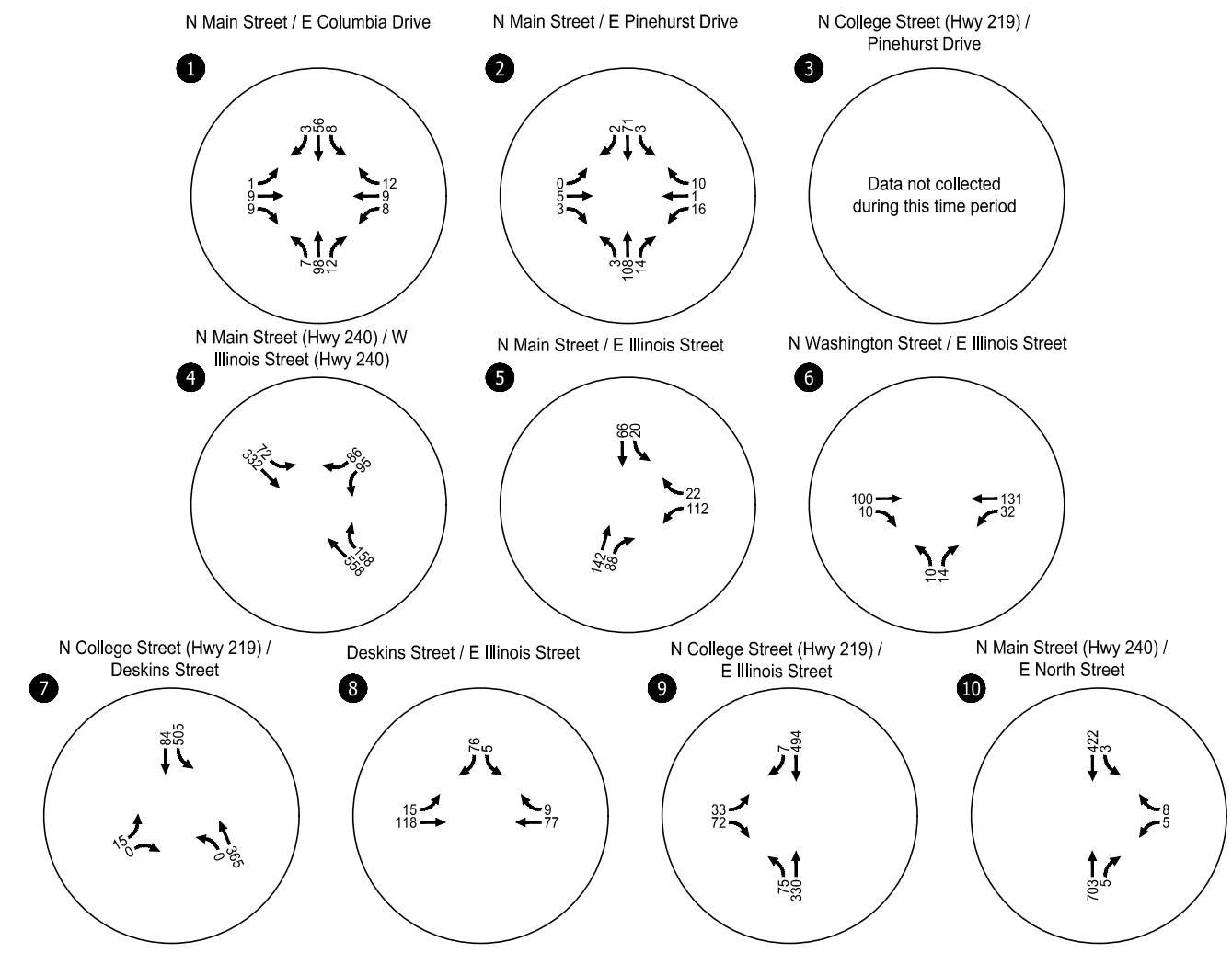

Existing Year 2023 Traffic Volumes
PM Peak Hour
Newberg, OR

Figure
4

H:\28544 - N Main at Illinois Intersection Study\report\figs\28544_Existing Conditions.dwg Feb 05, 2024 - 11:02am - mhagen Layout Tab: Existing SAT Volumes

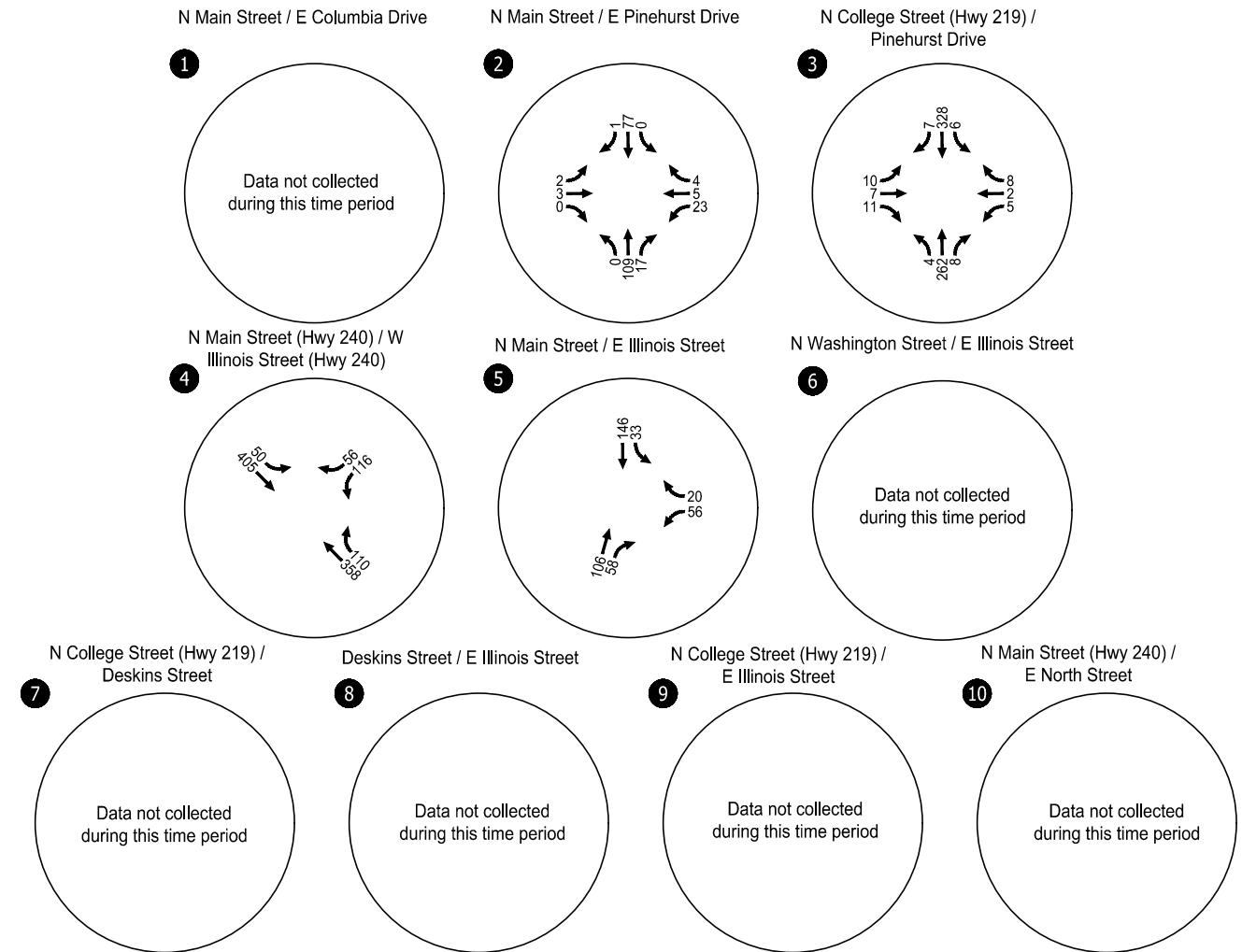
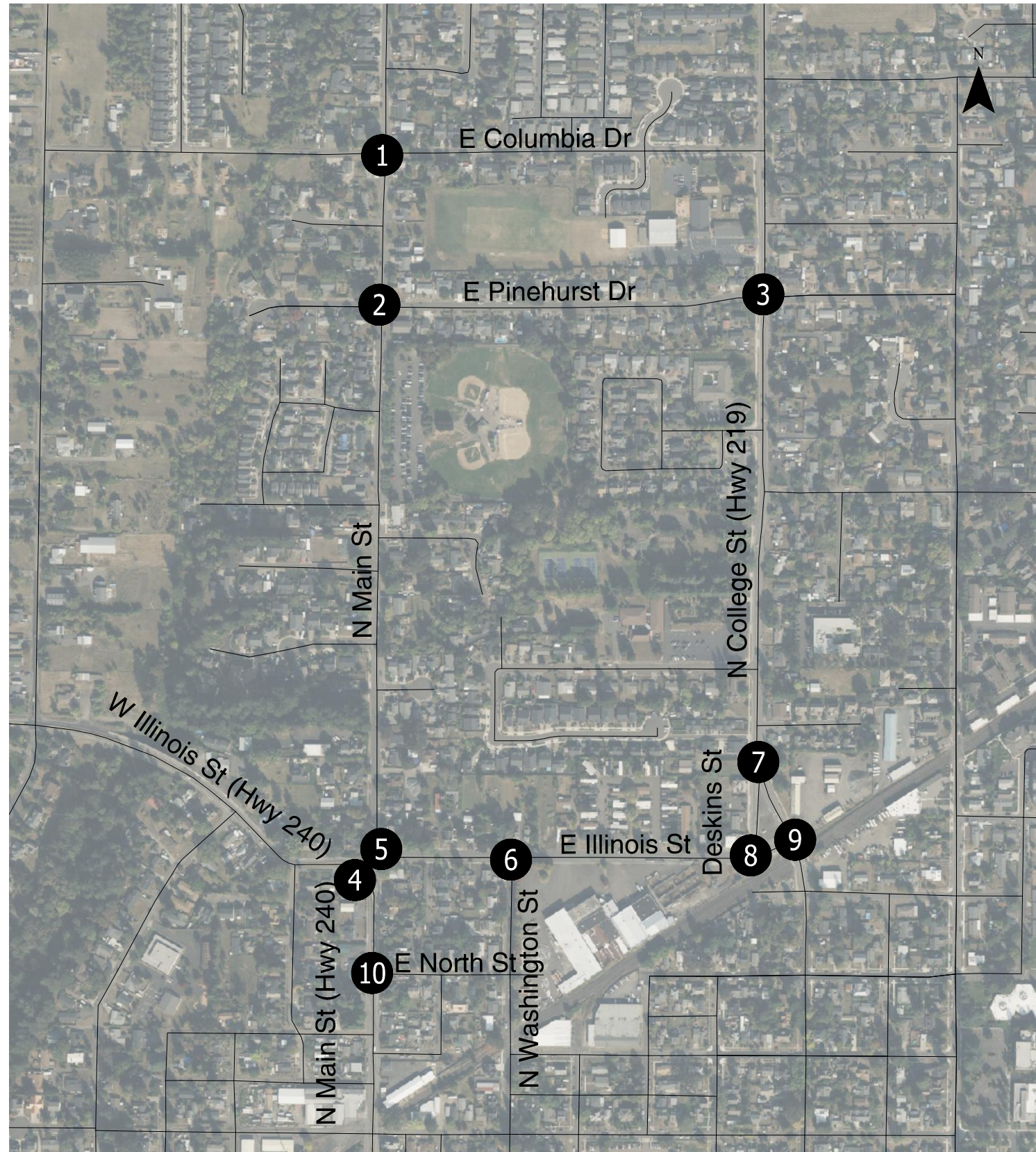

Existing Year 2023 Traffic Volumes
SAT Peak Hour
Newberg, OR

Figure
5

PEDESTRIAN AND BICYCLE DATA

Table 3 summarizes the recorded pedestrian and bicycle counts at the combined project intersection of N Main Street / Illinois Street. There are no crosswalks currently across Hwy 240 and bike lanes are not fully complete in the intersection area. As shown in the table, the highest pedestrian and bicycle volumes were recorded during the Saturday midday period.

Table 3. Pedestrian and Bicycle Data

Time Period	Pedestrian Volume	Bicycle Volume
AM Peak Hour	10	6
PM Peak Hour	1	2
SAT Peak Hour	17	6

Attachment "A" contains the collected pedestrian and bicycle counts within the traffic count sheets.

VEHICLE CLASSIFICATION DATA

Table 4 summarizes the recorded heavy vehicle percentages captured from traffic counts in September 2023 over a one-week period for the roadway segments connected to the N Main Street / Illinois Street intersection. As shown below, the highest heavy vehicle percentages recorded were on N Main Street (Hwy 240) between W Illinois Street and E North Street.

Table 4. Vehicle Classification Data

Roadway	Heavy Vehicle Percentage ¹
N Main Street (btwn E Clifford Court and E Illinois Street) – NB	1.7%
N Main Street (btwn E Clifford Court and E Illinois Street) – SB	1.8%
N Main Street (Hwy 240) (btwn W Illinois Street and E North Street) – NB	5.7%
N Main Street (Hwy 240) (btwn W Illinois Street and E North Street) – SB	8.0%
E Illinois Street (btwn N Main Street and N Washington Street) – EB	1.9%
E Illinois Street (btwn N Main Street and N Washington Street) – WB	1.3%
W Illinois Street (Hwy 240) (btwn N Grant Street and N Main Street) – EB	5.1%
W Illinois Street (Hwy 240) (btwn N Grant Street and N Main Street) – WB	5.1%

¹Heavy vehicle percent assumed to include buses and vehicles with 3 or more axles.

Attachment "A" contains the collected vehicle classification data with the traffic count sheets.

SPEED DATA

Table 5 summarizes measured speed data captured from traffic counts in September 2023 over a one-week period for the roadway segments connected to the N Main Street / Illinois Street intersection. As shown in the table, the measured 85th percentile speeds tend to be slightly higher than the posted speeds in the study area.

Table 5. Speed Data

Roadway	Direction	Speed Limit (MPH ¹)	85 th Percentile (MPH ¹)
N Main Street (btwn E Clifford Court and E Illinois Street)	NB	25	30
	SB	25	30
N Main Street (Hwy 240) (btwn W Illinois Street and E North Street)	NB	25	28
	SB	25	31
E Illinois Street (btwn N Main Street and N Washington Street)	EB	25	29
	WB	25	30
W Illinois Street (Hwy 240) (btwn N Grant Street and N Main Street)	EB	25	25
	WB	25	28

¹MPH stands for miles per hour.

Attachment "B" includes the collected speed data sheets.

CRASH DATA

Kittelsohn obtained crash data for the study intersections through the Oregon Department of Transportation (ODOT) self-service online database. The crash history was provided for January 2017 through December 2021. Tables 6 and 7 summarize the crash data over these 5 years for intersection and segment crashes, respectively. As shown, the most common crash types were rear-end and turning crashes. All crashes recorded were either property damage only or injury crashes. At the project intersection, seven crashes have been recorded with a crash rate of 0.29 crashes per million entering vehicles. Within ODOT's Analysis Procedures Manual (Reference 2), the 90th percentile crash rate performance standard is used to compare intersections against 500 other studied intersections and thus has developed the highest 10th percentile for crash rates that should be flagged for further analysis. Assuming a four-legged stop-controlled intersection in an urban setting, the 90th percentile crash rate is 0.408 which is greater than the recorded crash rate of 0.29 crashes per million entering vehicles for the project intersection.

Attachment "C" includes the crash data received from ODOT's self-service tool.

Table 6. Crash Summary Study Intersections

Intersection	Crash Type					Crash Severity		Total
	Rear-End	Fixed Object	Turning	Angle	Other	PDO	Injury	
N Main Street / E Columbia Street	-	-	-	-	-	-	-	0
N Main Street / E Pinehurst Drive	-	-	-	-	-	-	-	0
N College Street (Hwy 219) / E Pinehurst Drive	1	-	-	-	-	-	1	1
N Main Street / Illinois Street (Combined Project Intersection)	1	1	3	1	1	4	3	7
N Washington Street / E Illinois Street	-	1	-	-	-	-	1	1
Deskins Street / N College Street (Hwy 219)	-	-	-	-	-	-	-	0
Deskins Street / E Illinois Street	-	-	-	-	-	-	-	0
N College Street (Hwy 219) / E Illinois Street	-	-	2	-	-	1	1	2
N Main Street (Hwy 240) / E North Street	-	-	-	-	-	-	-	0
Total	2	2	5	1	1	5	6	11

Table 7. Crash Summary Study Area Segments

Intersection	Crash Type				Crash Severity		Total
	Rear-End	Fixed Object	Turning	Side Swipe	PDO	Injury	
N Main Street (E Columbia Drive to E Illinois Street)	1	-	-	1	-	2	2
E Pinehurst Drive (N Main Street to N College Street (Hwy 219))	-	-	-	-	-	-	0
Hwy 240 (N Morton Street to E North Street)	5	2	-	-	4	3	7
E Illinois Street (N Main Street to N College Street)	-	-	1	-	1	-	1
Deskins Street (N College Street to E Illinois Street)	-	-	-	-	-	-	0
Total	6	2	1	1	5	5	10

In addition, Oregon Department of Transportation's Safety Priority Index System (SPIS) lists Hwy 240 at N Main Street as a safety priority corridor in the top 15% of highway links from the most recent report in 2021 (Reference 3).

EXISTING TRAFFIC OPERATIONS

This section summarizes the operational performance of the study intersections under existing conditions. The operational performance relates the ability of the intersection to serve the flow of traffic.

APPLICABLE OPERATING STANDARDS

Analysis Methodology

The intersection operations analyses described in this report were performed in accordance with the procedures stated in the Highway Capacity Manual 6th Edition (HCM 6th) (Reference 4) using Synchro 11 software, with the exception of overall intersection level of service which was calculated using Synchro 11 with the 2000 Highway Capacity Manual (HCM 2000) (Reference 5).

Intersection Performance Measures

Several performance measures are used to assess the overall quality of the travel experience through an intersection or roadway segment as it is perceived by the traveler. A brief description of each performance measure is provided below.

Level of service (LOS) has been the most commonly used performance measure. LOS uses an "A" to "F" ranking based on the average control delay experienced by motorists. LOS "A" conditions show very low vehicle delay times (10 seconds or less), while LOS "F" conditions have high delay times (over 80 seconds per vehicle at a signalized intersection).

Level of service for signalized intersections is based on a weighted average per-vehicle control delay for the intersection while the analyses for two-way stop-controlled intersections are based on the delay at minor approaches and the major street left-turn movements. No delay is assumed on the major street through movements; levels of service and volume-to-capacity ratios are only calculated for each minor street lane.

Volume-to-capacity ratio (v/c) compares the volume of traffic to the theoretical capacity of the facility to accommodate traffic. A v/c ratio of 1.0 indicates an intersection is operating at capacity. A v/c ratio over 1.0 indicates the intersection's capacity is exceeded, meaning that the vehicle may have to wait more than one signal cycle length at a signalized intersection before moving through the intersection.

All intersection evaluations in this study used the peak 15-minute flow rates occurring at each study intersection during each of the peak hour analysis periods. Using the peak 15-minute flow rates ensures that the analysis is based on worst-case conditions. For this reason, the analysis reflects conditions that are only likely to occur for 15 minutes out of each average peak hour.

Operational Standards

The operational standards that are relevant for this analysis are as follows:

- City of Newberg: LOS D or better.
- ODOT (District Highways (Hwy 240) with posted speed 35MPH or less): v/c ratio of 0.95 or less.
- ODOT (Statewide Highways (Hwy 219) with posted speed 35MPH or less): v/c ratio of 0.90 or less.

OPERATIONAL ANALYSIS RESULTS

Table 8 below summarizes the AM peak hour, PM peak hour, and Saturday midday traffic operations results. Not all intersections were counted for each analyzed time period. The Saturday midday conditions were evaluated to understand the effects of Jaquith Park activities on a typical Saturday, and therefore, the four key intersections near Jaquith park were analyzed.

Attachment "D" includes the detailed traffic operations worksheets for each of the study intersections.

Table 8. Year 2023 Existing Traffic Operations

No.	Intersection	Intersection Control	Mobility Target	Lane Group	Weekday AM Peak Hour			Weekday PM Peak Hour			Saturday Midday Peak Hour		
					V/C	LOS	Delay	V/C	LOS	Delay	V/C	LOS	Delay
1	N Main Street / E Columbia Drive ²	AWSC	LOS D	NBLTR	0.14	A	7.7	0.16	A	7.8	-	-	-
				EBLTR	0.05	A	8.3	0.03	A	7.3	-	-	-
				WBLTR	0.05	A	7.6	0.04	A	7.6	-	-	-
				SBLTR	0.11	A	7.7	0.10	A	7.8	-	-	-
2	N Main Street / E Pinehurst Drive	TWSC	LOS D	NBLTR	0.00	A	0.0	0.01	A	7.7	-	-	-
				EBLTR	0.01	B	10.4	0.01	B	10.2	0.02	B	11.6
				WBLTR	0.02	A	9.6	0.04	B	10.0	0.10	B	11.7
				SBLTR	0.01	A	7.4	0.01	A	7.5	-	-	-
3	N College Street (Hwy 219) / E Pinehurst Drive ¹	TWSC	v/c 0.90 / LOS D	NBLTR	-	-	-	-	-	-	0.01	A	8.0
				EBLTR	-	-	-	-	-	-	0.07	B	13.7
				WBLTR	-	-	-	-	-	-	0.03	B	12.6
				SBLTR	-	-	-	-	-	-	0.01	A	7.8
4	W Illinois Street (Hwy 240) / N Main Street (Hwy 240)	TWSC	v/c 0.95 / LOS D	NWTR	-	-	-	-	-	-	-	-	-
				SELT	0.09	A	8.5	0.09	A	9.7	0.05	A	8.6
				SWLR	0.49	D	28.1	0.78	F	55.1	0.61	D	32.6
5	N Main Street / E Illinois Street	TWSC	LOS D	NWLR	0.06	A	3.1	0.10	A	4.9	0.08	A	5.0
				WBLR	0.19	B	13.9	0.36	C	18.0	0.26	C	18.0
				SBLR	0.16	B	10.3	0.12	A	10.0	0.26	B	10.3
6	N Washington Street / E Illinois Street ²	TWSC	LOS D	NBLR	0.03	A	9.7	0.04	A	9.8	-	-	-
				EBTR	-	-	-	-	-	-	-	-	-
				WBLT	0.01	A	7.7	0.03	A	7.6	-	-	-
7	N College Street (Hwy 219) / Deskins Street ²	TWSC	v/c 0.90 / LOS D	NBLT	0.01	A	8.4	-	-	-	-	-	-
				EBTR	0.03	C	16.3	0.06	C	19.9	-	-	-
				SBTR	-	-	-	-	-	-	-	-	-
8	Deskins Street / E Illinois Street ²	TWSC	LOS D	EBLT	0.01	A	7.3	0.01	A	7.4	-	-	-
				WBTR	-	-	-	-	-	-	-	-	-
				SBLR	0.08	A	9.0	0.10	A	9.3	-	-	-
9	N College Street (Hwy 219) / E Illinois Street ²	TWSC	v/c 0.90 / LOS D	NBLT	0.05	A	8.4	0.08	A	8.8	-	-	-
				EBLR	0.40	C	18.2	0.31	C	19.1	-	-	-
				SBTR	-	-	-	-	-	-	-	-	-
10	Main Street (Hwy 240) / E North Street ²	TWSC	v/c 0.95 / LOS D	NBTR	-	-	-	-	-	-	-	-	-
				WBLR	0.01	B	14.4	0.05	C	18.5	-	-	-
				SBLT	0.01	A	8.1	0.01	A	9.2	-	-	-

V/C ratio is defined as vehicle-to-capacity ratio, which calculates the number of vehicles divided by the capacity of the intersection during the peak 15 minutes of the peak hour. LOS stands for Level of Service. Delay is reported in seconds per vehicle. Cells in the table above that are **bolded**, *italicized*, and **highlighted** indicate a lane group operating below the jurisdictional standards.

¹Intersection turning movement counts were not collected for the AM and PM peak hours. ²Intersection turning movement counts were not collected for the SAT peak hour.

As shown in Table 8 above, all but one of the study intersections operate acceptably under year 2023 existing conditions. The intersection of N Main St (Hwy 240) & E Illinois St (Hwy 240) operates at LOS D in the AM peak hour, LOS F in the PM peak hour, and LOS D in the Saturday peak hour for the critical southwest bound approach.

CONCLUSION

This analysis of year 2023 existing conditions found that the project intersection of N Main Street / Illinois Street is currently not meeting the City's performance target. The intersection operates at LOS F during the PM peak hour, with drivers experiencing the highest delays on the southbound (stop-controlled) approach. All other study intersections are currently operating within the City's performance target.

There is also a lack of accessible crosswalks across Hwy 240 at the project intersection as well as incomplete bicycle lanes throughout the project area.

Next steps in the project will include preparing design alternatives for the N Main Street / Illinois Street intersection and evaluating no-build and build scenarios under future year 2043 traffic conditions.

REFERENCES

1. City of Newberg. *Transportation System Plan*. December 2016.
2. Oregon Department of Transportation. *Analysis Procedures Manual*. Updated September 2019.
3. Oregon Department of Transportation. *Safety Priority Index System*. 2021.
4. Transportation Research Board. *Highway Capacity Manual, 6th Edition*. April 2016.
5. Transportation Research Board. *Highway Capacity Manual 2000*. 2000.

ATTACHMENTS

- A. Traffic Counts
- B. Speed Data
- C. Crash Data
- D. Existing Year 2023 Traffic Operations Worksheets

Attachment A

Traffic Counts

LOCATION: N Main St -- E Columbia Dr
CITY/STATE: Newberg, OR

QC JOB #: 16302701
DATE: Thu, Sep 14 2023

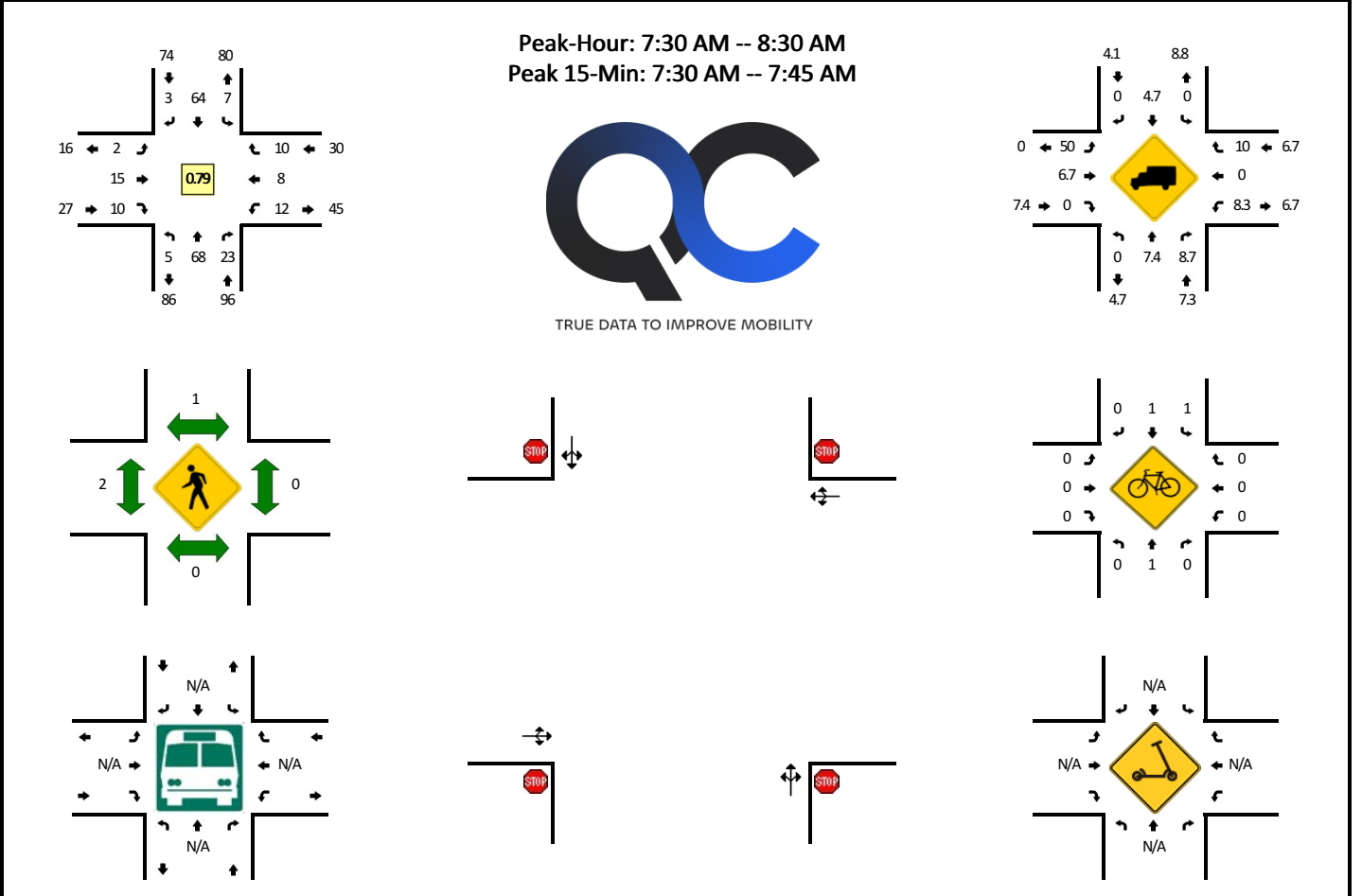

5-Min Count Period Beginning At	N Main St (Northbound)				N Main St (Southbound)				E Columbia Dr (Eastbound)				E Columbia Dr (Westbound)				Total	Hourly Totals
	Left	Thru	Right	U	Left	Thru	Right	U	Left	Thru	Right	U	Left	Thru	Right	U		
7:00 AM	0	5	1	0	1	6	0	0	0	0	0	0	1	0	2	0	16	
7:05 AM	2	5	0	0	0	2	0	0	0	0	0	0	1	1	0	0	11	
7:10 AM	0	3	0	0	0	3	0	0	0	0	2	0	0	0	0	0	8	
7:15 AM	0	1	1	0	1	5	0	0	0	0	1	0	2	0	0	0	11	
7:20 AM	1	6	1	0	0	3	0	0	0	0	0	0	0	0	1	0	12	
7:25 AM	0	10	0	0	0	2	0	0	0	0	1	0	0	2	1	0	16	
7:30 AM	1	9	1	0	0	4	1	0	0	0	2	1	0	0	3	0	22	
7:35 AM	0	2	5	0	0	8	0	0	0	0	0	2	0	3	1	0	21	
7:40 AM	0	4	1	0	3	13	0	0	0	0	3	2	0	2	0	1	29	
7:45 AM	1	4	1	0	1	9	0	0	1	2	0	0	1	1	0	0	21	
7:50 AM	0	7	2	0	1	1	0	0	0	2	0	0	1	0	0	0	14	
7:55 AM	0	8	4	0	0	2	1	0	0	0	1	0	1	1	1	0	19	200
8:00 AM	1	9	3	0	0	6	0	0	0	2	0	0	1	0	0	0	22	206
8:05 AM	0	7	0	0	1	3	1	0	0	0	0	0	1	2	0	0	15	210
8:10 AM	1	5	2	0	0	8	0	0	0	1	1	0	0	1	1	0	20	222
8:15 AM	1	5	2	0	0	3	0	0	0	1	0	0	1	1	1	0	15	226
8:20 AM	0	2	1	0	1	3	0	0	0	1	3	0	0	0	1	0	12	226
8:25 AM	0	6	1	0	0	4	0	0	1	1	0	0	1	1	2	0	17	227
8:30 AM	0	4	0	0	1	3	0	0	1	0	1	0	0	0	0	0	10	215
8:35 AM	0	2	0	0	0	1	0	0	1	1	0	0	1	1	0	0	7	201
8:40 AM	0	1	1	0	1	2	0	0	0	1	0	0	0	1	0	0	7	179
8:45 AM	0	3	1	0	1	3	1	0	0	0	0	0	0	2	0	0	11	169
8:50 AM	0	2	0	0	0	3	0	0	0	0	0	0	0	0	0	0	5	160
8:55 AM	0	1	0	0	0	2	0	0	0	0	0	0	0	0	0	0	3	144
Peak 15-Min Flowrates	Northbound				Southbound				Eastbound				Westbound				Total	
	Left	Thru	Right	U	Left	Thru	Right	U	Left	Thru	Right	U	Left	Thru	Right	U		
All Vehicles	4	60	28	0	12	100	4	0	0	20	20	0	20	4	16	0	288	
Heavy Trucks	0	0	0		0	0	0		0	0	0		0	0	0		0	
Buses																		
Pedestrians		0				4				4				0			8	
Bicycles	0	0	0		4	0	0		0	0	0		0	0	0		4	
Scoters																		

Comments:

LOCATION: N Main St -- E Columbia Dr
CITY/STATE: Newberg, OR

QC JOB #: 16302702
DATE: Thu, Sep 14 2023

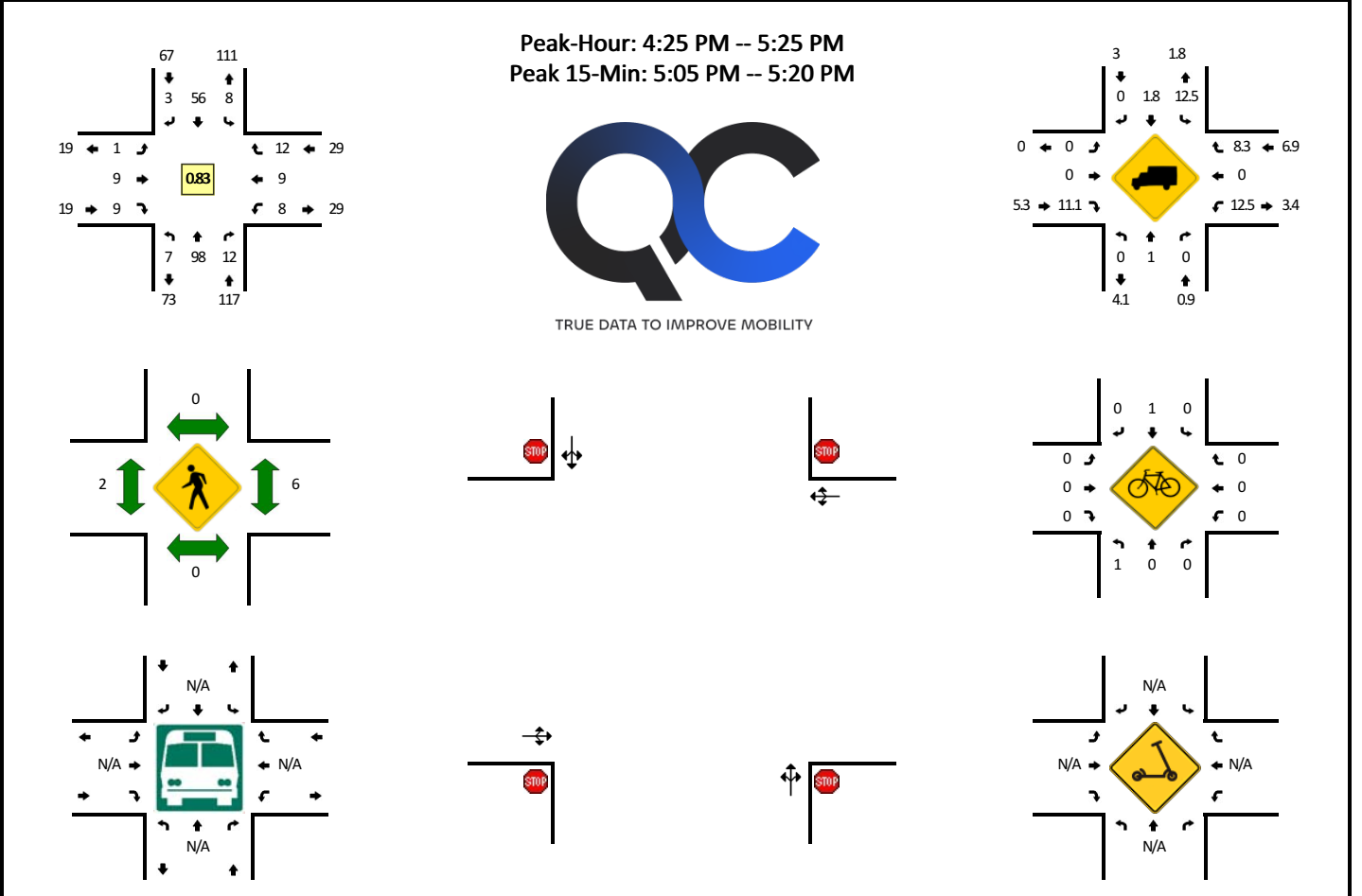

5-Min Count Period Beginning At	N Main St (Northbound)				N Main St (Southbound)				E Columbia Dr (Eastbound)				E Columbia Dr (Westbound)				Total	Hourly Totals
	Left	Thru	Right	U	Left	Thru	Right	U	Left	Thru	Right	U	Left	Thru	Right	U		
4:00 PM	0	3	1	0	1	2	0	0	0	2	0	0	2	0	1	0	12	
4:05 PM	1	3	0	0	1	1	1	0	0	0	0	0	1	0	1	0	9	
4:10 PM	0	2	1	0	0	2	0	0	0	0	0	1	0	1	1	0	8	
4:15 PM	1	5	1	0	0	0	0	0	0	0	0	0	1	1	0	0	9	
4:20 PM	0	4	1	0	1	7	0	0	0	0	0	0	0	0	3	0	16	
4:25 PM	0	9	0	0	1	7	0	0	0	0	1	2	1	0	0	0	21	
4:30 PM	0	8	2	0	1	3	0	0	0	0	1	0	2	0	1	0	18	
4:35 PM	2	5	0	0	1	6	0	0	0	0	2	0	0	0	2	0	18	
4:40 PM	1	7	2	0	0	4	1	0	0	0	1	1	0	1	0	0	18	
4:45 PM	0	9	1	0	1	6	0	0	0	0	0	1	0	1	0	0	19	
4:50 PM	0	6	2	0	0	0	0	0	0	0	0	1	0	2	2	0	13	
4:55 PM	0	9	1	0	1	3	1	0	1	0	0	0	1	0	1	0	18	179
5:00 PM	0	6	1	0	1	4	0	0	0	0	1	0	0	1	1	0	15	182
5:05 PM	1	13	0	0	2	5	0	0	0	0	1	2	0	2	2	0	28	201
5:10 PM	1	6	1	0	0	10	0	0	0	0	1	1	0	0	2	0	24	217
5:15 PM	0	11	1	0	0	2	0	0	0	0	1	0	0	2	1	0	18	226
5:20 PM	2	9	1	0	0	6	1	0	0	0	0	1	0	1	0	0	22	232
5:25 PM	0	4	1	0	1	3	0	0	0	0	0	1	0	1	0	0	11	222
5:30 PM	0	8	0	0	2	6	0	0	0	0	0	0	0	0	0	0	16	220
5:35 PM	0	8	2	0	1	4	0	0	0	0	0	0	2	0	0	0	17	219
5:40 PM	1	6	2	0	0	2	3	0	0	0	0	2	0	0	1	0	17	218
5:45 PM	0	4	1	0	0	2	0	0	1	1	0	0	0	1	1	0	11	210
5:50 PM	1	13	0	0	0	5	1	0	0	0	1	0	0	0	1	0	22	219
5:55 PM	0	5	2	0	0	6	0	0	0	0	0	0	0	0	1	0	14	215
Peak 15-Min Flowrates	Northbound				Southbound				Eastbound				Westbound				Total	
	Left	Thru	Right	U	Left	Thru	Right	U	Left	Thru	Right	U	Left	Thru	Right	U		
All Vehicles	8	120	8	0	8	68	0	0	0	12	12	0	8	20	16	0	280	
Heavy Trucks	0	4	0	0	0	4	0	0	0	0	0	0	0	0	0	0	8	
Buses																		
Pedestrians	0	0			0	0			8				0	0			8	
Bicycles	0	0	0		0	0	0		0	0	0		0	0	0		0	
Scoters																		

Comments:

LOCATION: N Main St -- E Pinehurst Dr
CITY/STATE: Newberg, OR

QC JOB #: 16302703
DATE: Thu, Sep 14 2023

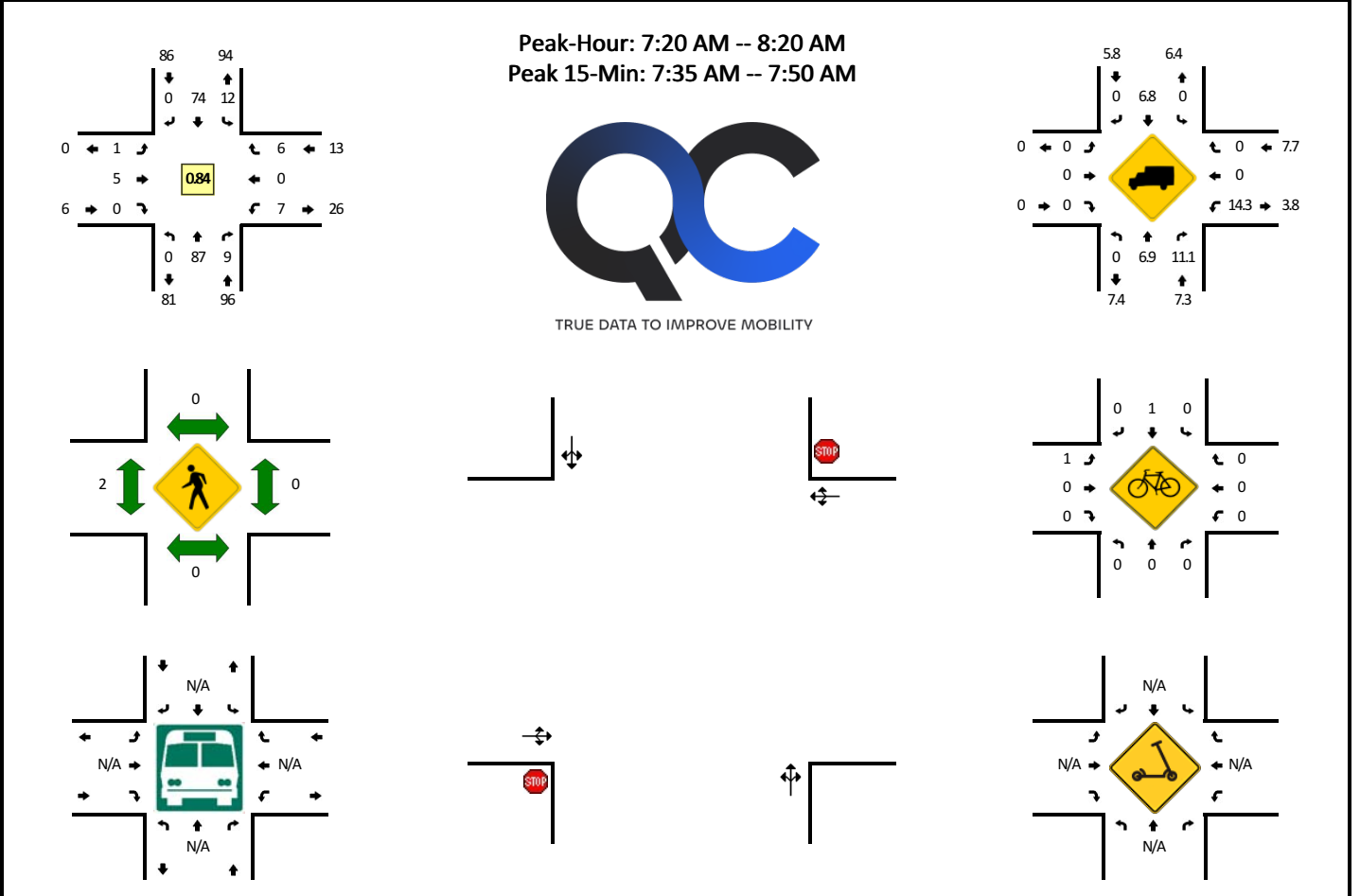

5-Min Count Period Beginning At	N Main St (Northbound)				N Main St (Southbound)				E Pinehurst Dr (Eastbound)				E Pinehurst Dr (Westbound)				Total	Hourly Totals
	Left	Thru	Right	U	Left	Thru	Right	U	Left	Thru	Right	U	Left	Thru	Right	U		
7:00 AM	0	7	0	0	1	5	0	0	0	0	0	0	0	0	0	0	13	
7:05 AM	0	5	0	0	0	3	0	0	0	0	0	0	0	0	0	0	8	
7:10 AM	0	3	0	0	1	3	0	0	0	0	0	0	0	0	0	0	7	
7:15 AM	0	2	0	0	0	6	0	0	0	0	0	0	0	1	1	0	10	
7:20 AM	0	5	1	0	0	5	0	0	0	0	1	0	0	0	0	2	14	
7:25 AM	0	9	0	0	2	1	0	0	0	0	1	0	0	0	0	0	13	
7:30 AM	0	9	1	0	2	5	0	0	0	0	0	0	0	0	0	0	17	
7:35 AM	0	3	0	0	2	9	0	0	0	0	1	0	0	1	0	0	16	
7:40 AM	0	5	0	0	3	13	0	0	0	0	0	0	0	0	0	0	21	
7:45 AM	0	8	1	0	1	12	0	0	0	0	0	0	0	0	1	0	23	
7:50 AM	0	7	1	0	0	1	0	0	0	0	1	0	0	1	0	2	13	
7:55 AM	0	12	1	0	0	5	0	0	0	0	0	0	0	2	0	0	20	175
8:00 AM	0	8	3	0	0	7	0	0	0	1	0	0	0	1	0	0	20	182
8:05 AM	0	9	0	0	1	4	0	0	0	0	0	0	0	0	0	1	15	189
8:10 AM	0	5	0	0	0	9	0	0	0	0	1	0	0	1	0	0	16	198
8:15 AM	0	7	1	0	1	3	0	0	0	0	0	0	0	1	0	0	13	201
8:20 AM	0	2	0	0	1	2	0	0	0	0	0	0	0	0	0	0	5	192
8:25 AM	0	4	0	0	1	4	0	0	0	1	0	0	0	0	0	1	11	190
8:30 AM	0	4	0	0	0	4	0	0	0	0	0	0	0	0	0	0	8	181
8:35 AM	0	3	0	0	0	2	0	0	0	0	0	0	0	0	0	0	5	170
8:40 AM	0	2	0	0	0	2	0	0	0	0	0	0	0	3	0	0	7	156
8:45 AM	0	4	0	0	0	1	0	0	0	0	0	0	0	0	0	0	5	138
8:50 AM	1	1	1	0	0	4	0	0	0	0	1	0	0	0	1	1	10	135
8:55 AM	0	1	2	0	0	2	0	0	0	0	0	0	0	0	0	0	5	120
Peak 15-Min Flowrates	Northbound				Southbound				Eastbound				Westbound				Total	
	Left	Thru	Right	U	Left	Thru	Right	U	Left	Thru	Right	U	Left	Thru	Right	U		
All Vehicles	0	64	4	0	24	136	0	0	0	4	0	0	4	0	4	0	240	
Heavy Trucks	0	4	0	0	0	0	0	0	0	0	0	0	0	0	0	0	4	
Buses																		
Pedestrians	0	0			0	0			0	0			0	0			0	
Bicycles	0	0			0	0			0	0			0	0			0	
Scoters																		

Comments:

LOCATION: N Main St -- E Pinehurst Dr
CITY/STATE: Newberg, OR

QC JOB #: 16302704
DATE: Thu, Sep 14 2023

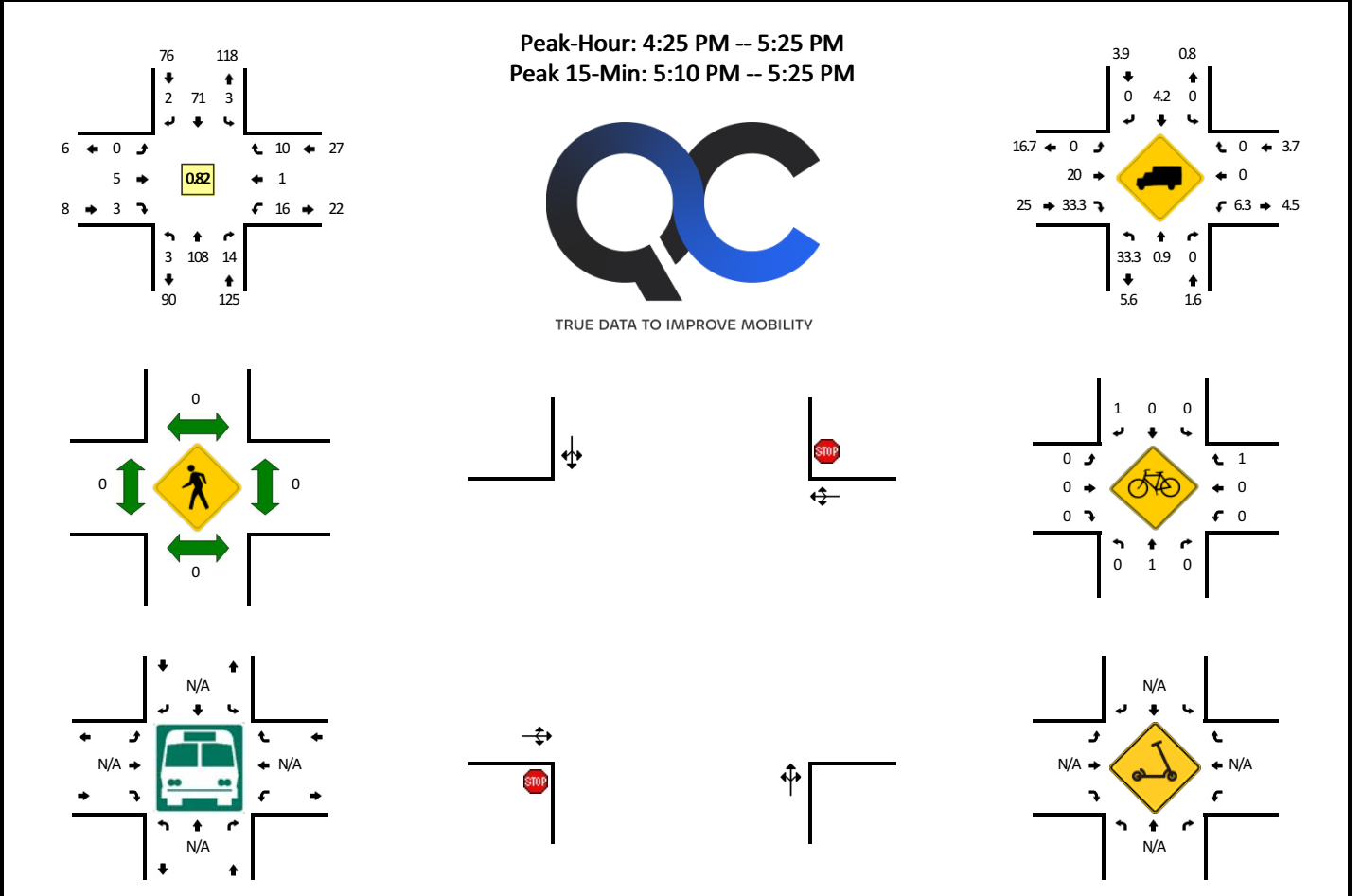

5-Min Count Period Beginning At	N Main St (Northbound)				N Main St (Southbound)				E Pinehurst Dr (Eastbound)				E Pinehurst Dr (Westbound)				Total	Hourly Totals
	Left	Thru	Right	U	Left	Thru	Right	U	Left	Thru	Right	U	Left	Thru	Right	U		
4:00 PM	0	5	0	0	0	3	0	0	0	0	1	0	0	0	0	0	9	
4:05 PM	0	4	1	0	0	2	0	0	0	0	0	0	0	1	0	0	8	
4:10 PM	0	2	1	0	0	4	0	0	0	0	0	0	0	0	1	0	8	
4:15 PM	0	7	0	0	0	3	0	0	0	0	0	0	0	0	0	0	10	
4:20 PM	0	5	1	0	1	7	0	0	0	0	0	0	0	1	0	0	15	
4:25 PM	0	8	0	0	0	9	0	0	0	0	1	0	0	0	0	1	19	
4:30 PM	1	10	1	0	0	6	0	0	0	0	0	0	1	0	0	0	19	
4:35 PM	0	7	1	0	0	6	1	0	0	0	2	0	1	0	1	0	19	
4:40 PM	0	9	0	0	0	6	0	0	0	0	0	0	1	0	0	0	16	
4:45 PM	0	7	2	0	1	6	0	0	0	0	0	0	0	0	3	0	19	
4:50 PM	0	8	1	0	1	2	0	0	0	0	0	0	0	0	2	0	14	
4:55 PM	0	10	2	0	0	3	0	0	0	0	0	0	1	0	0	0	16	172
5:00 PM	0	9	1	0	0	4	0	0	0	0	1	0	3	1	1	0	20	183
5:05 PM	0	11	2	0	0	6	0	0	0	0	1	0	2	0	0	0	22	197
5:10 PM	1	6	1	0	0	11	0	0	0	0	1	0	4	0	1	0	25	214
5:15 PM	1	12	3	0	0	5	0	0	0	0	1	1	1	0	0	0	24	228
5:20 PM	0	11	0	0	1	7	1	0	0	0	0	0	2	0	1	0	23	236
5:25 PM	0	6	1	0	0	4	0	0	0	0	0	0	0	0	0	0	11	228
5:30 PM	0	8	2	0	0	6	0	0	0	0	0	0	2	0	0	0	18	227
5:35 PM	1	10	2	0	0	6	0	0	0	0	0	0	1	0	0	0	20	228
5:40 PM	0	7	0	0	0	4	0	0	0	0	0	0	2	0	2	0	15	227
5:45 PM	0	4	2	0	0	1	1	0	0	0	0	0	1	0	2	0	11	219
5:50 PM	0	15	1	0	1	4	1	0	0	0	0	0	0	0	0	0	22	227
5:55 PM	0	7	1	0	0	6	0	0	0	0	0	0	2	1	2	0	19	230
Peak 15-Min Flowrates	Northbound				Southbound				Eastbound				Westbound				Total	
	Left	Thru	Right	U	Left	Thru	Right	U	Left	Thru	Right	U	Left	Thru	Right	U		
All Vehicles	8	116	16	0	4	92	4	0	0	8	4	0	28	0	8	0	288	
Heavy Trucks	4	0	0		0	4	0		0	4	0		0	0	0		12	
Buses																		
Pedestrians		0				0				0				0			0	
Bicycles		0				0				0				0			0	
Scoters																	0	

Comments:

LOCATION: N Main St -- Hwy 240
CITY/STATE: Newberg, OR

QC JOB #: 16302705
DATE: Thu, Sep 14 2023

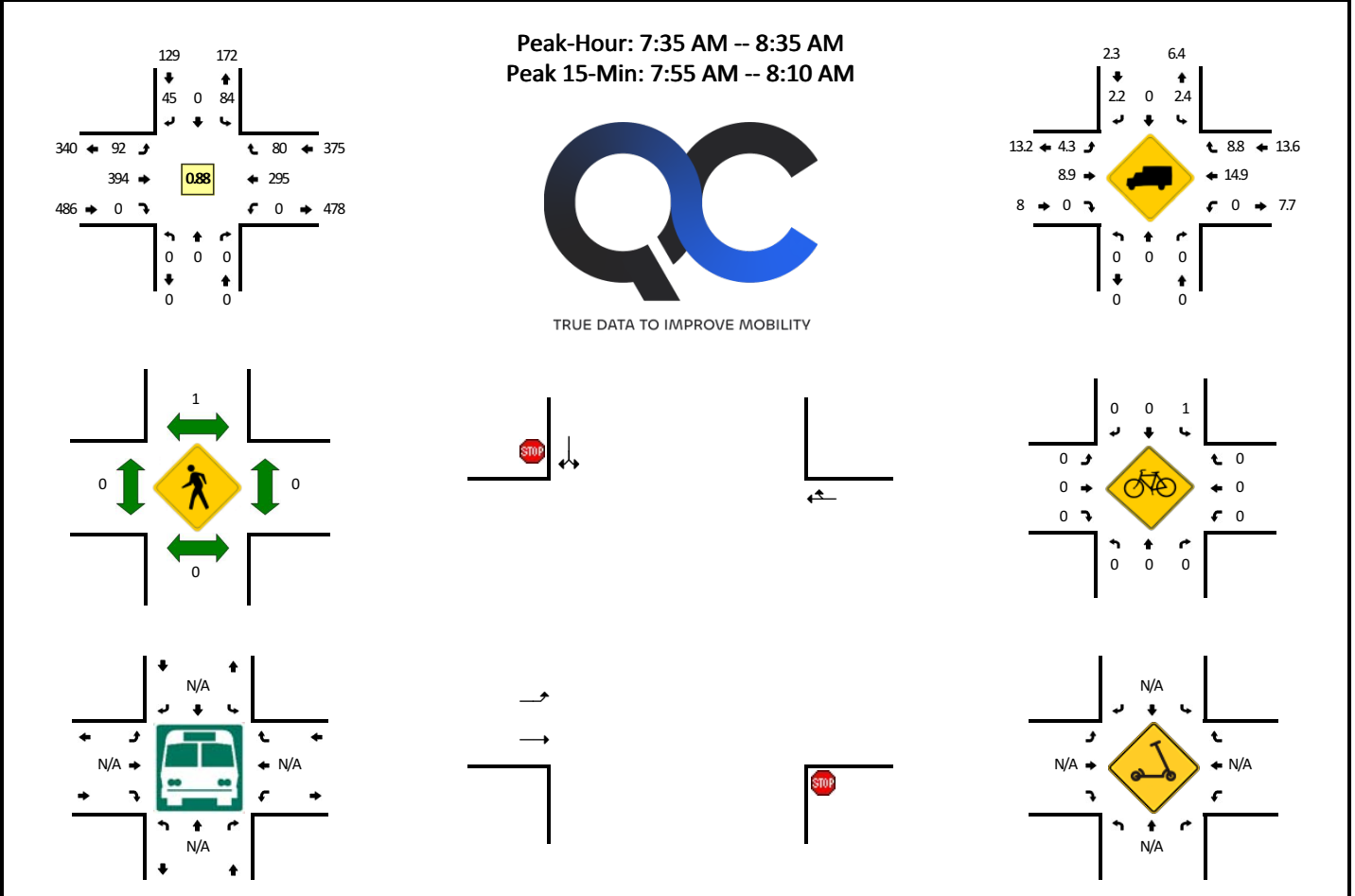

5-Min Count Period Beginning At	N Main St (Northbound)				N Main St (Southbound)				Hwy 240 (Eastbound)				Hwy 240 (Westbound)				Total	Hourly Totals
	Left	Thru	Right	U	Left	Thru	Right	U	Left	Thru	Right	U	Left	Thru	Right	U		
7:00 AM	0	0	0	0	7	0	3	0	3	19	0	0	0	25	7	0	64	
7:05 AM	0	0	0	0	4	0	1	0	2	31	0	0	0	18	4	0	60	
7:10 AM	0	0	0	0	3	0	2	0	2	38	0	0	0	14	5	0	64	
7:15 AM	0	0	0	0	5	0	1	0	3	32	0	0	0	22	3	0	66	
7:20 AM	0	0	0	0	10	0	1	0	4	32	0	0	0	14	3	0	64	
7:25 AM	0	0	0	0	6	0	0	0	6	33	0	0	0	13	6	0	64	
7:30 AM	0	0	0	0	5	0	2	0	4	25	0	0	0	18	5	0	59	
7:35 AM	0	0	0	0	12	0	5	0	4	39	0	0	0	29	4	0	93	
7:40 AM	0	0	0	0	6	0	3	0	13	29	0	0	0	29	1	0	81	
7:45 AM	0	0	0	0	13	0	7	0	10	36	0	0	0	24	4	0	94	
7:50 AM	0	0	0	0	4	0	1	0	12	33	0	0	0	32	10	0	92	
7:55 AM	0	0	0	0	5	0	7	0	12	28	0	0	0	25	17	0	94	895
8:00 AM	0	0	0	0	7	0	2	0	13	32	0	0	0	20	8	0	82	913
8:05 AM	0	0	0	0	9	0	3	0	9	38	0	0	0	37	10	0	106	959
8:10 AM	0	0	0	0	6	0	7	0	2	31	0	0	0	28	9	0	83	978
8:15 AM	0	0	0	0	5	0	3	0	5	32	0	0	0	18	3	0	66	978
8:20 AM	0	0	0	0	5	0	3	0	5	22	0	0	0	15	4	0	54	968
8:25 AM	0	0	0	0	6	0	2	0	2	44	0	0	0	17	4	0	75	979
8:30 AM	0	0	0	0	6	0	2	0	5	30	0	0	0	21	6	0	70	990
8:35 AM	0	0	0	0	5	0	2	0	4	27	0	0	0	23	2	0	63	960
8:40 AM	0	0	0	0	4	0	1	0	5	21	0	0	0	25	5	0	61	940
8:45 AM	0	0	0	0	5	0	2	0	5	24	0	0	0	27	7	0	70	916
8:50 AM	0	0	0	0	11	0	2	0	5	22	0	0	0	24	4	0	68	892
8:55 AM	0	0	0	0	5	0	2	0	8	28	0	0	0	27	5	0	75	873
Peak 15-Min Flowrates	Northbound				Southbound				Eastbound				Westbound				Total	
	Left	Thru	Right	U	Left	Thru	Right	U	Left	Thru	Right	U	Left	Thru	Right	U		
All Vehicles	0	0	0	0	84	0	48	0	136	392	0	0	0	328	140	0	1128	
Heavy Trucks	0	0	0	0	0	0	0	0	8	48	0	0	0	64	16	0	136	
Buses																		
Pedestrians	0	0	0	0	0	0	0	0	0	0	0	0	0	0	0	0	0	
Bicycles	0	0	0	0	0	0	0	0	0	0	0	0	0	0	0	0	0	
Scoters																		

Comments:

LOCATION: N Main St -- Hwy 240
CITY/STATE: Newberg, OR

QC JOB #: 16302706
DATE: Thu, Sep 14 2023

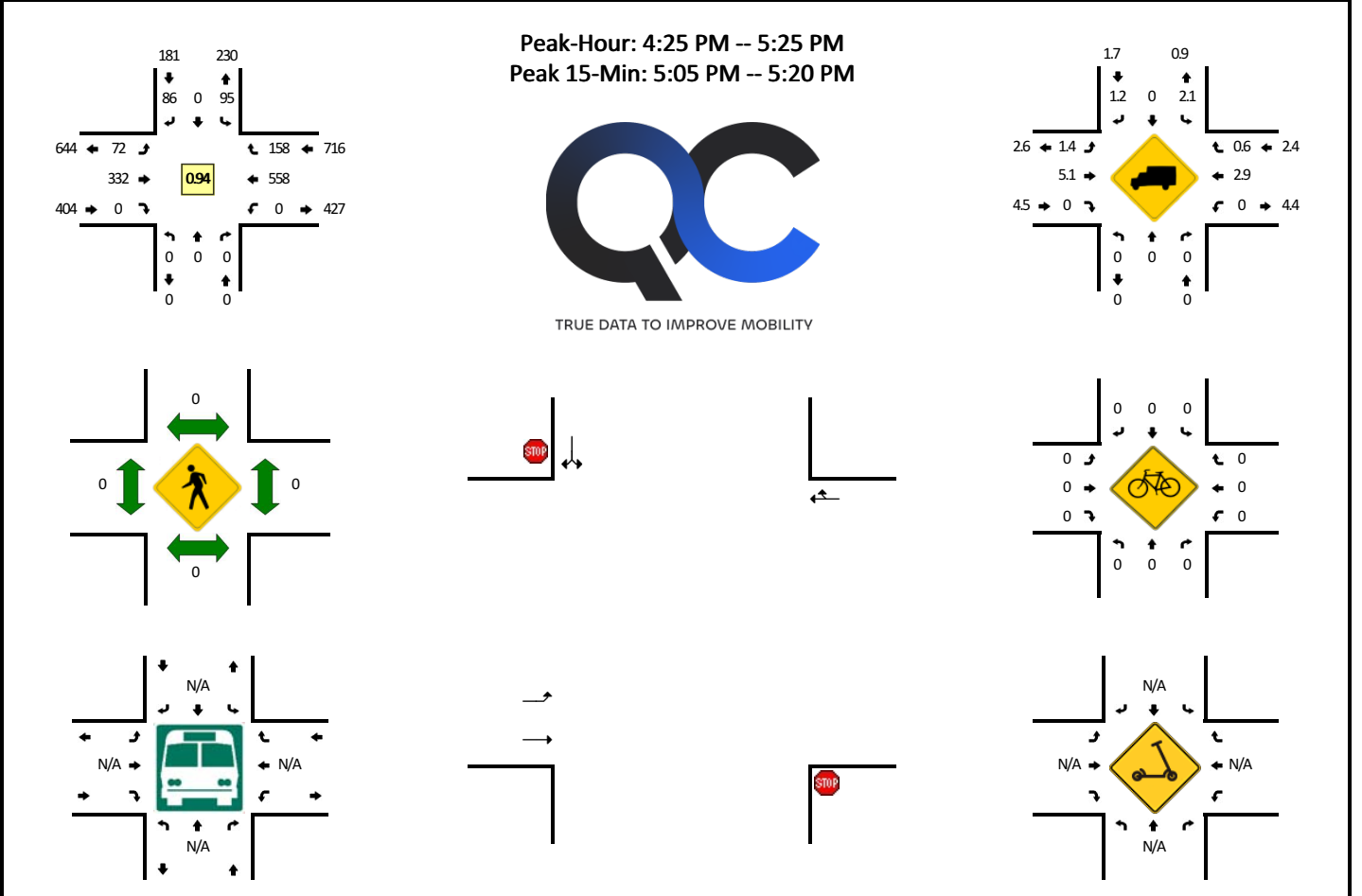

5-Min Count Period Beginning At	N Main St (Northbound)				N Main St (Southbound)				Hwy 240 (Eastbound)				Hwy 240 (Westbound)				Total	Hourly Totals
	Left	Thru	Right	U	Left	Thru	Right	U	Left	Thru	Right	U	Left	Thru	Right	U		
4:00 PM	0	0	0	0	3	0	3	0	2	26	0	0	0	35	9	0	78	
4:05 PM	0	0	0	0	13	0	7	0	10	29	0	0	0	37	6	0	102	
4:10 PM	0	0	0	0	4	0	7	0	0	32	0	0	0	49	8	0	100	
4:15 PM	0	0	0	0	4	0	5	0	7	35	0	0	0	39	10	0	100	
4:20 PM	0	0	0	0	4	0	4	0	2	30	0	0	0	46	13	0	99	
4:25 PM	0	0	0	0	11	0	4	0	3	32	0	0	0	44	12	0	106	
4:30 PM	0	0	0	0	8	0	9	0	7	25	0	0	0	44	13	0	106	
4:35 PM	0	0	0	0	9	0	9	0	6	19	0	0	0	47	11	0	101	
4:40 PM	0	0	0	0	4	0	4	0	4	39	0	0	0	52	11	0	114	
4:45 PM	0	0	0	0	10	0	6	0	3	27	0	0	0	49	11	0	106	
4:50 PM	0	0	0	0	5	0	6	0	11	29	0	0	0	46	13	0	110	
4:55 PM	0	0	0	0	4	0	2	0	11	17	0	0	0	40	12	0	86	1208
5:00 PM	0	0	0	0	8	0	8	0	4	26	0	0	0	50	17	0	113	1243
5:05 PM	0	0	0	0	6	0	9	0	5	32	0	0	0	54	13	0	119	1260
5:10 PM	0	0	0	0	9	0	11	0	2	24	0	0	0	51	12	0	109	1269
5:15 PM	0	0	0	0	8	0	7	0	10	28	0	0	0	48	16	0	117	1286
5:20 PM	0	0	0	0	13	0	11	0	6	34	0	0	0	33	17	0	114	1301
5:25 PM	0	0	0	0	5	0	8	0	3	33	0	0	0	43	11	0	103	1298
5:30 PM	0	0	0	0	8	0	4	0	4	27	0	0	0	35	20	0	98	1290
5:35 PM	0	0	0	0	10	0	3	0	3	17	0	0	0	45	15	0	93	1282
5:40 PM	0	0	0	0	8	0	5	0	4	25	0	0	0	33	14	0	89	1257
5:45 PM	0	0	0	0	3	0	4	0	7	42	0	0	0	45	11	0	112	1263
5:50 PM	0	0	0	0	12	0	7	0	1	29	0	0	0	44	10	0	103	1256
5:55 PM	0	0	0	0	10	0	5	0	4	26	0	0	0	34	10	0	89	1259
Peak 15-Min Flowrates	Northbound				Southbound				Eastbound				Westbound				Total	
	Left	Thru	Right	U	Left	Thru	Right	U	Left	Thru	Right	U	Left	Thru	Right	U		
All Vehicles	0	0	0	0	92	0	108	0	68	336	0	0	0	612	164	0	1380	
Heavy Trucks	0	0	0	0	8	0	0	0	4	20	0	0	0	8	0	0	40	
Buses	0	0	0	0	0	0	0	0	0	0	0	0	0	0	0	0	0	
Pedestrians	0	0	0	0	0	0	0	0	0	0	0	0	0	0	0	0	0	
Bicycles	0	0	0	0	0	0	0	0	0	0	0	0	0	0	0	0	0	
Scooters	0	0	0	0	0	0	0	0	0	0	0	0	0	0	0	0	0	

Comments:

LOCATION: N Main St -- E Illinois St
CITY/STATE: Newberg, OR

QC JOB #: 16302707
DATE: Thu, Sep 14 2023

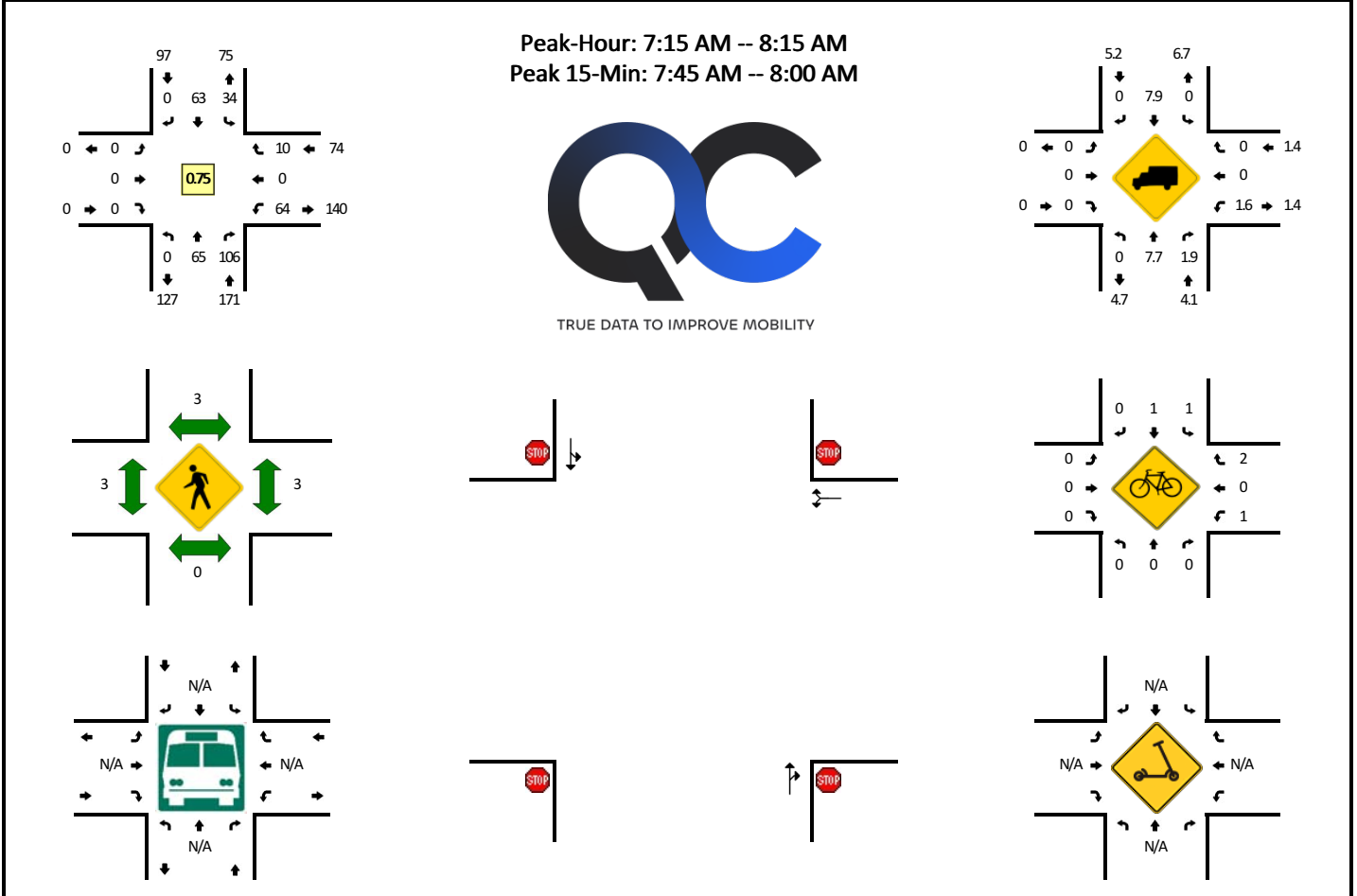

5-Min Count Period Beginning At	N Main St (Northbound)				N Main St (Southbound)				E Illinois St (Eastbound)				E Illinois St (Westbound)				Total	Hourly Totals
	Left	Thru	Right	U	Left	Thru	Right	U	Left	Thru	Right	U	Left	Thru	Right	U		
7:00 AM	0	5	5	0	2	5	0	0	0	0	0	0	5	0	0	0	22	
7:05 AM	0	1	5	0	1	3	0	0	0	0	0	0	2	0	0	0	12	
7:10 AM	0	2	5	0	4	3	0	0	0	0	0	0	2	0	1	0	17	
7:15 AM	0	1	5	0	4	6	0	0	0	0	0	0	2	0	0	0	18	
7:20 AM	0	4	3	0	3	6	0	0	0	0	0	0	3	0	0	0	19	
7:25 AM	0	6	6	0	1	3	0	0	0	0	0	0	6	0	0	0	22	
7:30 AM	0	7	2	0	2	2	0	0	0	0	0	0	3	0	4	0	20	
7:35 AM	0	2	6	0	2	8	0	0	0	0	0	0	9	0	1	0	28	
7:40 AM	0	2	11	0	1	7	0	0	0	0	0	0	4	0	0	0	25	
7:45 AM	0	4	11	0	6	12	0	0	0	0	0	0	5	0	1	0	39	
7:50 AM	0	5	16	0	2	2	0	0	0	0	0	0	4	0	0	0	29	
7:55 AM	0	12	18	0	2	3	0	0	0	0	0	0	8	0	3	0	46	297
8:00 AM	0	9	12	0	4	5	0	0	0	0	0	0	5	0	0	0	35	310
8:05 AM	0	7	11	0	3	4	0	0	0	0	0	0	8	0	0	0	33	331
8:10 AM	0	6	5	0	4	5	0	0	0	0	0	0	7	0	1	0	28	342
8:15 AM	0	4	4	0	0	4	0	0	0	0	0	0	5	0	1	0	18	342
8:20 AM	0	1	8	0	0	2	0	0	0	0	0	0	5	0	2	0	18	341
8:25 AM	0	4	2	0	0	4	0	0	0	0	0	0	5	0	0	0	15	334
8:30 AM	0	5	6	0	2	2	0	0	0	0	0	0	6	0	1	0	22	336
8:35 AM	0	2	4	0	0	4	0	0	0	0	0	0	3	0	0	0	13	321
8:40 AM	0	4	6	0	3	2	0	0	0	0	0	0	2	0	0	0	17	313
8:45 AM	0	5	7	0	1	2	0	0	0	0	0	0	5	0	0	0	20	294
8:50 AM	0	2	7	0	1	6	0	0	0	0	0	0	9	0	1	0	26	291
8:55 AM	0	3	9	0	3	2	0	0	0	0	0	0	5	0	1	0	23	268
Peak 15-Min Flowrates	Northbound				Southbound				Eastbound				Westbound				Total	
	Left	Thru	Right	U	Left	Thru	Right	U	Left	Thru	Right	U	Left	Thru	Right	U		
All Vehicles	0	84	180	0	40	68	0	0	0	0	0	0	68	0	16	0	456	
Heavy Trucks	0	0	8		0	8	0		0	0	0		4	0	0		20	
Buses																		
Pedestrians	0	0			0	0			0	0			0	0			0	
Bicycles	0	0			0	0			0	0			0	0			0	
Scoters																		

Comments: No stop sign for the NB approach.

LOCATION: N Main St -- E Illinois St
CITY/STATE: Newberg, OR

QC JOB #: 16302708
DATE: Thu, Sep 14 2023

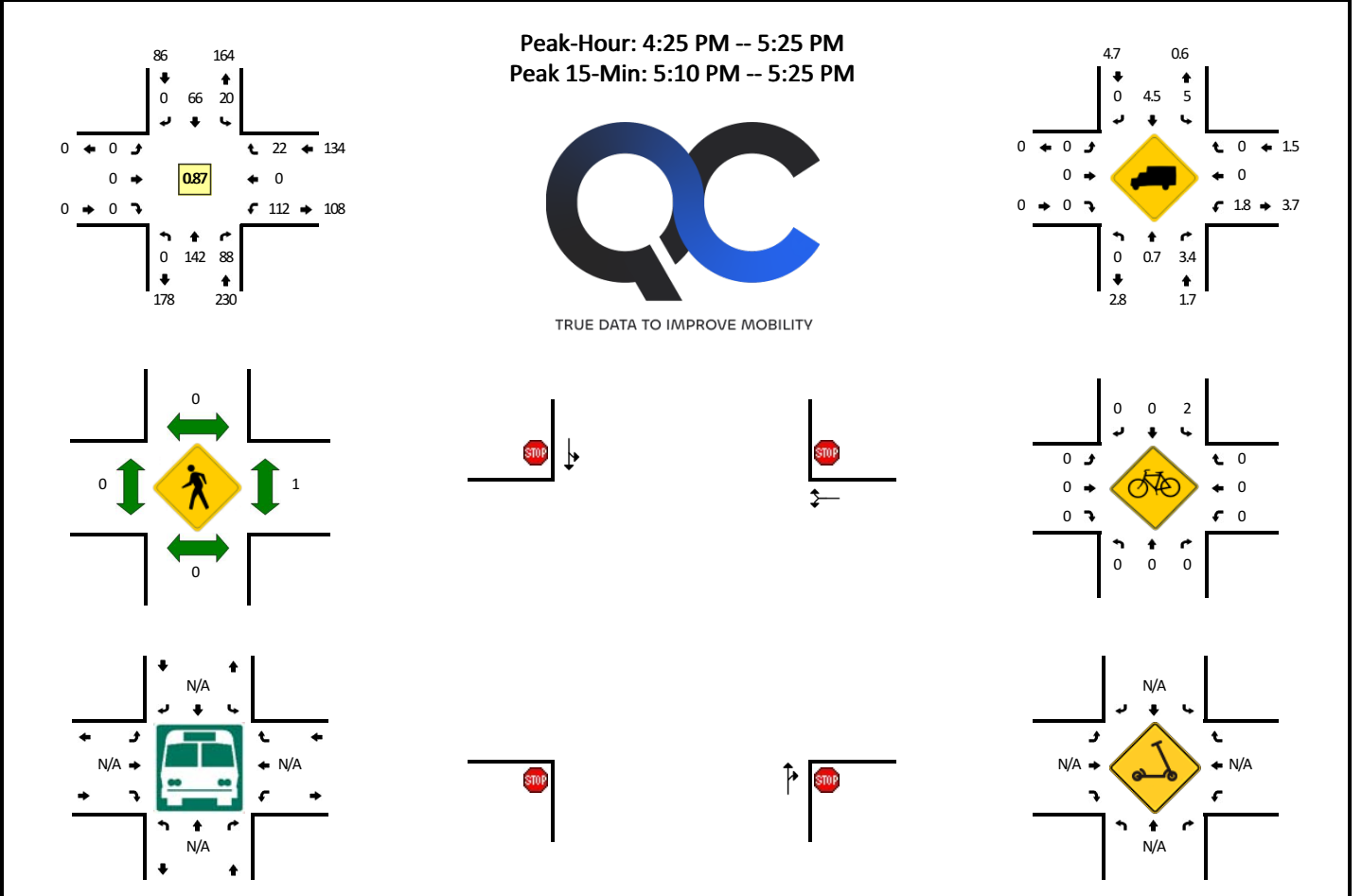

5-Min Count Period Beginning At	N Main St (Northbound)				N Main St (Southbound)				E Illinois St (Eastbound)				E Illinois St (Westbound)				Total	Hourly Totals
	Left	Thru	Right	U	Left	Thru	Right	U	Left	Thru	Right	U	Left	Thru	Right	U		
4:00 PM	0	7	4	0	1	4	0	0	0	0	0	0	2	0	0	0	18	
4:05 PM	0	7	8	0	1	6	0	0	0	0	0	0	16	0	3	0	41	
4:10 PM	0	5	2	0	2	3	0	0	0	0	0	0	8	0	2	0	22	
4:15 PM	0	10	6	0	0	1	0	0	0	0	0	0	6	0	0	0	23	
4:20 PM	0	10	6	0	2	4	0	0	0	0	0	0	5	0	2	0	29	
4:25 PM	0	11	5	0	1	7	0	0	0	0	0	0	10	0	2	0	36	
4:30 PM	0	13	6	0	2	6	0	0	0	0	0	0	12	0	4	0	43	
4:35 PM	0	9	8	0	0	7	0	0	0	0	0	0	7	0	2	0	33	
4:40 PM	0	10	5	0	2	3	0	0	0	0	0	0	6	0	2	0	28	
4:45 PM	0	9	5	0	2	7	0	0	0	0	0	0	9	0	3	0	35	
4:50 PM	0	12	14	0	1	1	0	0	0	0	0	0	9	0	0	0	37	
4:55 PM	0	10	13	0	1	2	0	0	0	0	0	0	4	0	2	0	32	377
5:00 PM	0	15	6	0	2	4	0	0	0	0	0	0	13	0	1	0	41	400
5:05 PM	0	13	4	0	3	7	0	0	0	0	0	0	7	0	1	0	35	394
5:10 PM	0	11	4	0	3	10	0	0	0	0	0	0	12	0	0	0	40	412
5:15 PM	0	15	10	0	1	4	0	0	0	0	0	0	10	0	3	0	43	432
5:20 PM	0	14	8	0	2	8	0	0	0	0	0	0	13	0	2	0	47	450
5:25 PM	0	7	6	0	1	4	0	0	0	0	0	0	11	0	1	0	30	444
5:30 PM	0	17	8	0	0	7	0	0	0	0	0	0	6	0	4	0	42	443
5:35 PM	0	16	3	0	3	7	0	0	0	0	0	0	3	0	1	0	33	443
5:40 PM	0	9	8	0	0	7	0	0	0	0	0	0	7	0	1	0	32	447
5:45 PM	0	10	8	0	0	2	0	0	0	0	0	0	6	0	0	0	26	438
5:50 PM	0	9	2	0	2	5	0	0	0	0	0	0	12	0	0	0	30	431
5:55 PM	0	7	7	0	1	7	0	0	0	0	0	0	10	0	0	0	32	431
Peak 15-Min Flowrates	Northbound				Southbound				Eastbound				Westbound				Total	
	Left	Thru	Right	U	Left	Thru	Right	U	Left	Thru	Right	U	Left	Thru	Right	U		
All Vehicles	0	160	88	0	24	88	0	0	0	0	0	0	140	0	20	0	520	
Heavy Trucks	0	0	8		0	8	0		0	0	0		4	0	0		20	
Buses																		
Pedestrians	0	0			0	0			0	0			0	0			0	
Bicycles	0	0			0	0			0	0			0	0			0	
Scoters																		

Comments: No stop sign for the NB approach.

LOCATION: N Washington St -- E Illinois St
CITY/STATE: Newberg, OR

QC JOB #: 16302709
DATE: Thu, Sep 14 2023

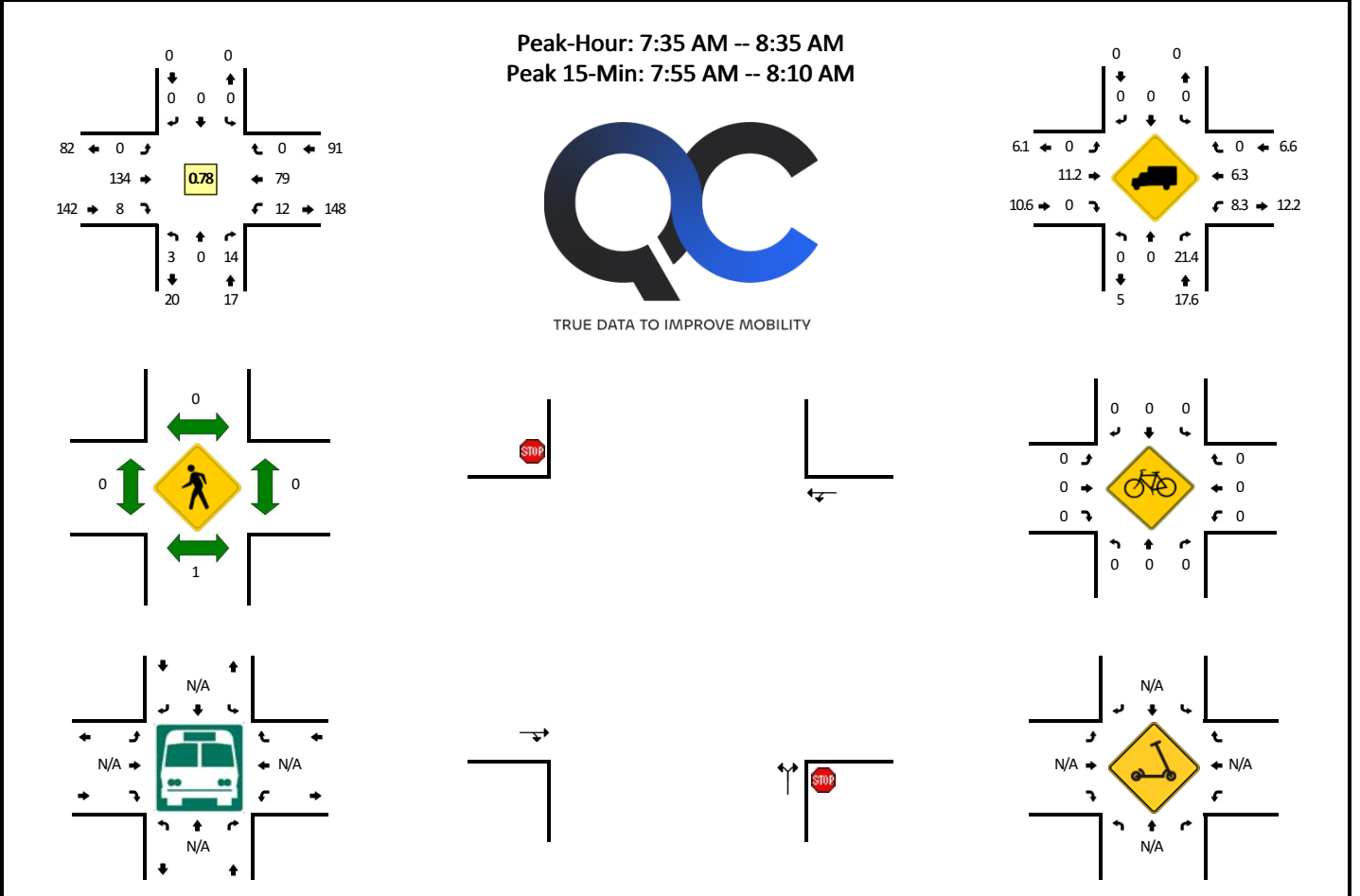

5-Min Count Period Beginning At	N Washington St (Northbound)				N Washington St (Southbound)				E Illinois St (Eastbound)				E Illinois St (Westbound)				Total	Hourly Totals	
	Left	Thru	Right	U	Left	Thru	Right	U	Left	Thru	Right	U	Left	Thru	Right	U			
7:00 AM	0	0	1	0	0	0	0	0	0	6	0	0	0	5	0	0	0	12	
7:05 AM	0	0	0	0	0	0	0	0	0	7	1	0	0	2	2	0	0	12	
7:10 AM	0	0	3	0	0	0	0	0	0	9	0	0	0	1	2	0	0	15	
7:15 AM	0	0	0	1	0	0	0	0	0	8	2	0	0	3	2	0	0	16	
7:20 AM	0	0	0	0	0	0	0	0	0	8	1	0	0	0	3	0	0	12	
7:25 AM	0	0	2	0	0	0	0	0	0	7	0	0	0	0	5	0	0	14	
7:30 AM	1	0	0	0	0	0	0	0	0	3	1	0	0	0	6	0	0	11	
7:35 AM	0	0	4	0	0	0	0	0	0	8	0	0	0	1	9	0	0	22	
7:40 AM	0	0	1	0	0	0	0	0	0	12	0	0	0	0	5	0	0	18	
7:45 AM	1	0	1	0	0	0	0	0	0	14	3	0	0	0	6	0	0	25	
7:50 AM	0	0	0	0	0	0	0	0	0	17	0	0	0	0	2	0	0	19	
7:55 AM	1	0	0	0	0	0	0	0	0	20	1	0	0	0	10	0	0	32	208
8:00 AM	0	0	0	0	0	0	0	0	0	17	0	0	0	2	5	0	0	24	220
8:05 AM	0	0	0	0	0	0	0	0	0	15	1	0	0	0	8	0	0	24	232
8:10 AM	1	0	1	0	0	0	0	0	0	9	2	0	0	3	8	0	0	24	241
8:15 AM	0	0	4	0	0	0	0	0	0	3	0	0	0	2	6	0	0	15	240
8:20 AM	0	0	2	0	0	0	0	0	0	8	0	0	0	0	7	0	0	17	245
8:25 AM	0	0	1	0	0	0	0	0	0	4	0	0	0	1	6	0	0	12	243
8:30 AM	0	0	0	0	0	0	0	0	0	7	1	0	0	3	7	0	0	18	250
8:35 AM	0	0	0	0	0	0	0	0	0	4	0	0	0	1	4	0	0	9	237
8:40 AM	0	0	0	0	0	0	0	0	0	7	1	0	0	0	3	0	0	11	230
8:45 AM	0	0	0	0	0	0	0	0	0	8	0	0	0	1	5	0	0	14	219
8:50 AM	0	0	0	0	0	0	0	0	0	8	0	0	0	1	9	0	0	18	218
8:55 AM	0	0	3	0	0	0	0	0	0	13	0	0	0	0	8	0	0	24	210
Peak 15-Min Flowrates	Northbound				Southbound				Eastbound				Westbound				Total		
	Left	Thru	Right	U	Left	Thru	Right	U	Left	Thru	Right	U	Left	Thru	Right	U			
All Vehicles	4	0	0	0	0	0	0	0	0	208	8	0	0	8	92	0	0	320	
Heavy Trucks	0	0	0	0	0	0	0	0	0	32	0	0	0	0	0	0	0	32	
Buses																			
Pedestrians		4				0				0					0			4	
Bicycles	0	0	0		0	0	0			0	0			0	0	0		0	
Scoters																			

Comments:

LOCATION: N Washington St -- E Illinois St
CITY/STATE: Newberg, OR

QC JOB #: 16302710
DATE: Thu, Sep 14 2023

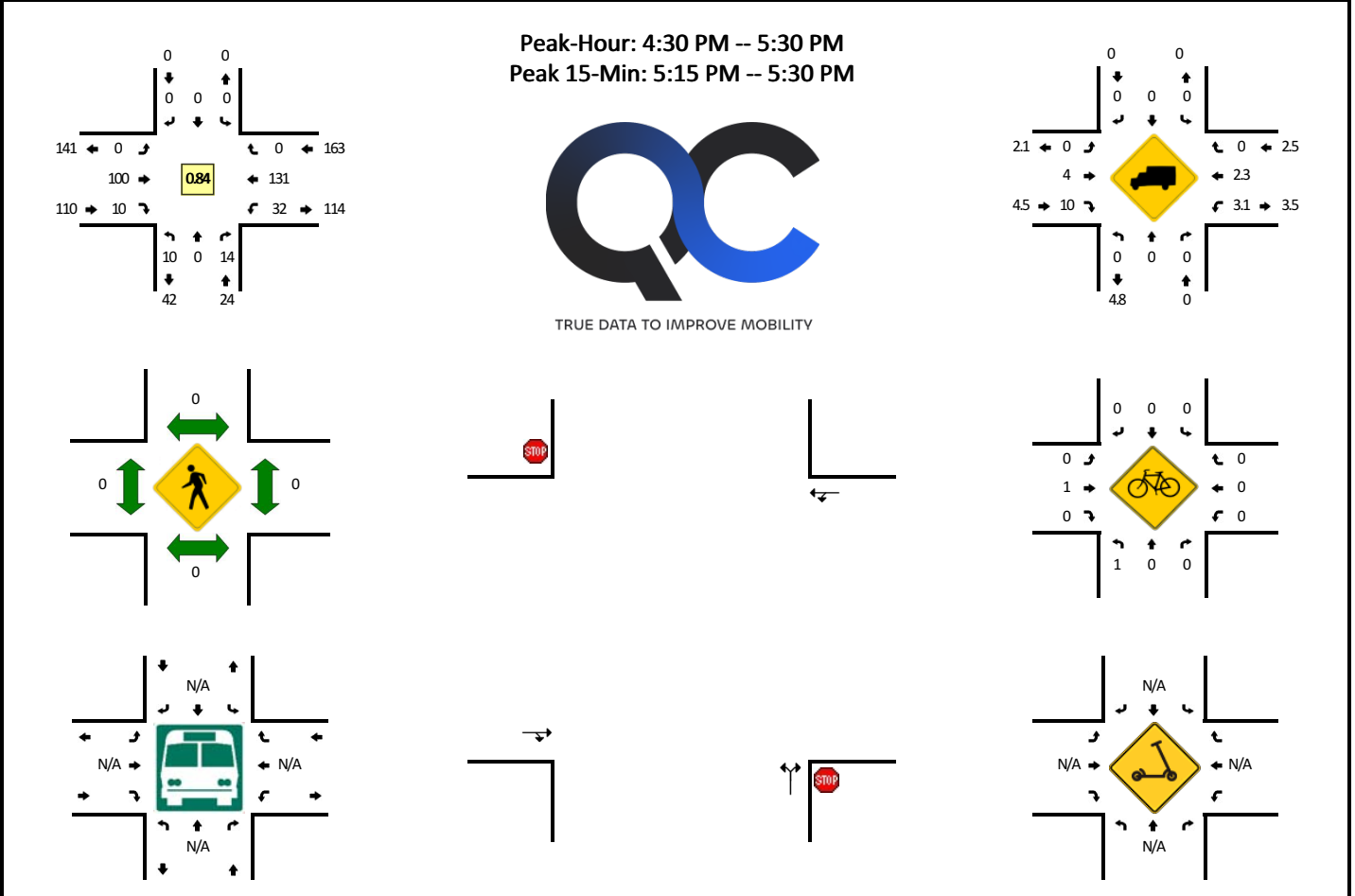

5-Min Count Period Beginning At	N Washington St (Northbound)				N Washington St (Southbound)				E Illinois St (Eastbound)				E Illinois St (Westbound)				Total	Hourly Totals
	Left	Thru	Right	U	Left	Thru	Right	U	Left	Thru	Right	U	Left	Thru	Right	U		
4:00 PM	1	0	0	0	0	0	0	0	0	5	0	0	2	2	0	0	10	
4:05 PM	0	0	0	0	0	0	0	0	0	8	0	0	3	19	0	0	30	
4:10 PM	1	0	0	0	0	0	0	0	0	4	1	0	4	10	0	0	20	
4:15 PM	0	0	0	0	0	0	0	0	0	6	1	0	1	6	0	0	14	
4:20 PM	1	0	3	0	0	0	0	0	0	6	1	0	3	9	0	0	23	
4:25 PM	0	0	1	0	0	0	0	0	0	5	0	0	3	11	0	0	20	
4:30 PM	4	0	0	0	0	0	0	0	0	7	0	0	1	14	0	0	26	
4:35 PM	0	0	1	0	0	0	0	0	0	9	0	0	5	10	0	0	25	
4:40 PM	2	0	1	0	0	0	0	0	0	6	1	0	1	7	0	0	18	
4:45 PM	1	0	2	0	0	0	0	0	0	6	0	0	2	10	0	0	21	
4:50 PM	0	0	1	0	0	0	0	0	0	14	0	0	2	11	0	0	28	
4:55 PM	1	0	2	0	0	0	0	0	0	15	0	0	2	5	0	0	25	260
5:00 PM	2	0	0	0	0	0	0	0	0	6	2	0	4	13	0	0	27	277
5:05 PM	0	0	1	0	0	0	0	0	0	8	1	0	2	7	0	0	19	266
5:10 PM	0	0	0	0	0	0	0	0	0	4	2	0	1	13	0	0	20	266
5:15 PM	0	0	3	0	0	0	0	0	0	10	1	0	3	18	0	0	35	287
5:20 PM	0	0	2	0	0	0	0	0	0	9	2	0	2	10	0	0	25	289
5:25 PM	0	0	1	0	0	0	0	0	0	6	1	0	7	13	0	0	28	297
5:30 PM	3	0	0	0	0	0	0	0	0	9	0	0	0	7	0	0	19	290
5:35 PM	0	0	2	0	0	0	0	0	0	5	1	0	3	7	0	0	18	283
5:40 PM	0	0	0	0	0	0	0	0	0	9	0	0	1	7	0	0	17	282
5:45 PM	0	0	0	0	0	0	0	0	0	9	0	0	2	10	0	0	21	282
5:50 PM	0	0	1	0	0	0	0	0	0	2	1	0	3	9	0	0	16	270
5:55 PM	0	0	0	0	0	0	0	0	0	9	0	0	0	12	0	0	21	266
Peak 15-Min Flowrates	Northbound				Southbound				Eastbound				Westbound				Total	
	Left	Thru	Right	U	Left	Thru	Right	U	Left	Thru	Right	U	Left	Thru	Right	U		
All Vehicles	0	0	24	0	0	0	0	0	0	100	16	0	48	164	0	0	352	
Heavy Trucks	0	0	0	0	0	0	0	0	0	4	0	0	4	0	0	0	8	
Buses																		
Pedestrians		0				0				0				0			0	
Bicycles	4	0	0		0	0	0			0	0		0	0	0		4	
Scoters																		

Comments:

LOCATION: N College St -- Deskins St
CITY/STATE: Newberg, OR

QC JOB #: 16302711
DATE: Thu, Sep 14 2023

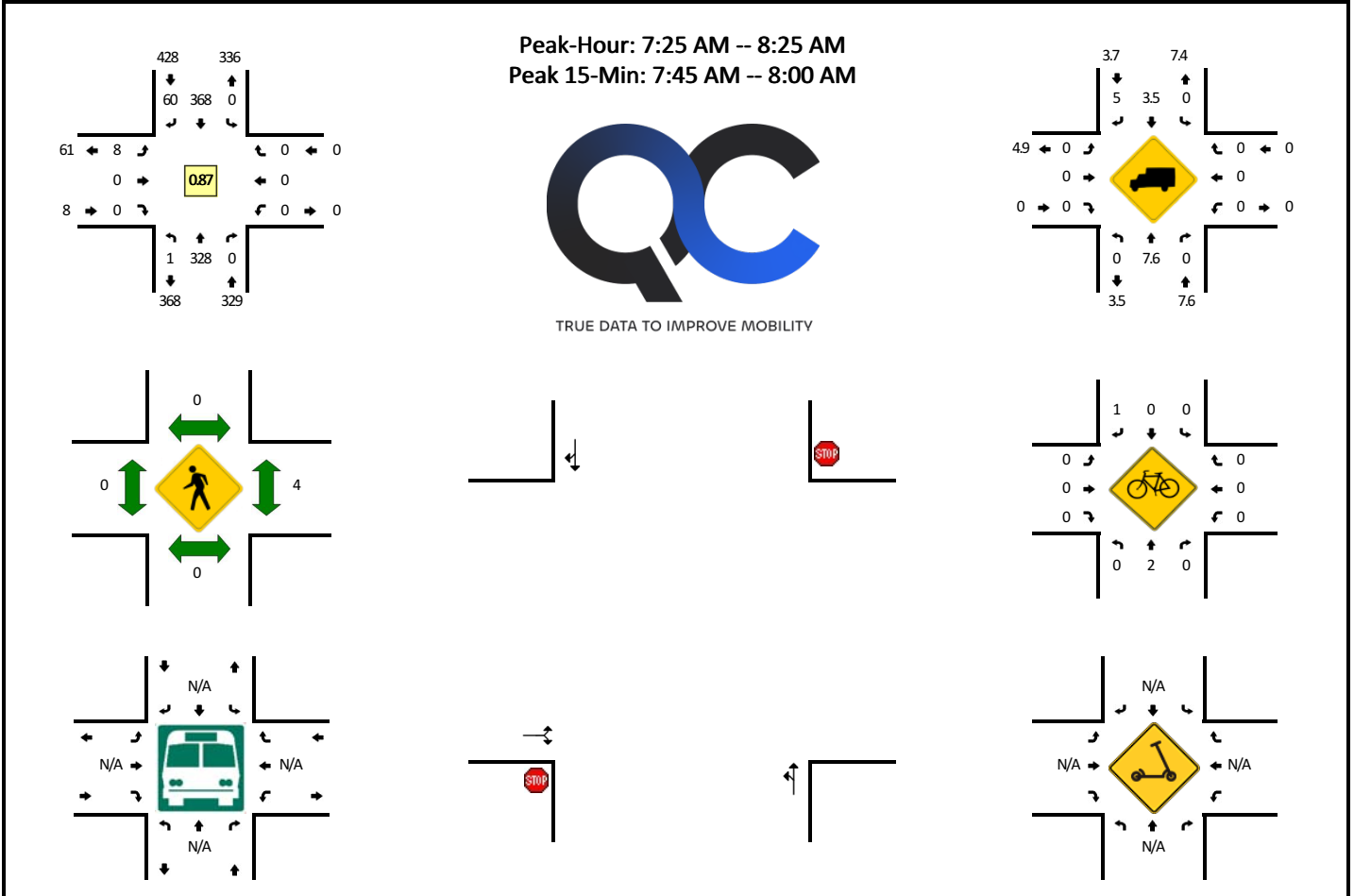

5-Min Count Period Beginning At	N College St (Northbound)				N College St (Southbound)				Deskins St (Eastbound)				Deskins St (Westbound)				Total	Hourly Totals
	Left	Thru	Right	U	Left	Thru	Right	U	Left	Thru	Right	U	Left	Thru	Right	U		
7:00 AM	0	20	0	0	0	26	2	0	1	0	1	0	0	0	0	0	50	
7:05 AM	0	12	0	0	0	22	5	0	0	0	0	0	0	0	0	0	39	
7:10 AM	0	18	0	0	0	16	4	0	1	0	0	0	0	0	0	0	39	
7:15 AM	0	25	0	0	0	24	4	0	0	0	0	0	0	0	0	0	53	
7:20 AM	0	19	0	0	0	24	3	0	0	0	0	0	0	0	0	0	46	
7:25 AM	0	28	0	0	0	23	3	0	0	0	0	0	0	0	0	0	54	
7:30 AM	0	16	0	0	0	36	7	0	1	0	0	0	0	0	0	0	60	
7:35 AM	0	29	0	0	0	23	5	0	0	0	0	0	0	0	0	0	57	
7:40 AM	0	23	0	0	0	33	7	0	0	0	0	0	0	0	0	0	63	
7:45 AM	0	42	0	0	0	32	4	0	2	0	0	0	0	0	0	0	80	
7:50 AM	0	35	0	0	0	35	3	0	1	0	0	0	0	0	0	0	74	
7:55 AM	0	27	0	0	0	32	7	0	0	0	0	0	0	0	0	0	66	681
8:00 AM	1	26	0	0	0	39	8	0	0	0	0	0	0	0	0	0	74	705
8:05 AM	0	33	0	0	0	25	5	0	1	0	0	0	0	0	0	0	64	730
8:10 AM	0	23	0	0	0	29	5	0	2	0	0	0	0	0	0	0	59	750
8:15 AM	0	18	0	0	0	39	3	0	0	0	0	0	0	0	0	0	60	757
8:20 AM	0	28	0	0	0	22	3	0	1	0	0	0	0	0	0	0	54	765
8:25 AM	0	14	0	0	0	32	8	0	0	0	0	0	0	0	0	0	54	765
8:30 AM	0	19	0	0	0	21	8	0	1	0	0	0	0	0	0	0	49	754
8:35 AM	0	10	0	0	0	18	4	0	1	0	0	0	0	0	0	0	33	730
8:40 AM	0	24	0	0	0	13	2	0	0	0	0	0	0	0	0	0	39	706
8:45 AM	0	21	0	0	0	29	6	0	1	0	0	0	0	0	0	0	57	683
8:50 AM	0	12	0	0	0	27	10	0	2	0	0	0	0	0	0	0	51	660
8:55 AM	1	19	0	0	0	11	4	0	0	0	0	0	0	0	0	0	35	629
Peak 15-Min Flowrates	Northbound				Southbound				Eastbound				Westbound				Total	
	Left	Thru	Right	U	Left	Thru	Right	U	Left	Thru	Right	U	Left	Thru	Right	U		
All Vehicles	0	416	0	0	0	396	56	0	12	0	0	0	0	0	0	0	880	
Heavy Trucks	0	32	0	0	0	4	8	0	0	0	0	0	0	0	0	0	44	
Buses																		
Pedestrians	0	0			0	0			0	0			0	0			0	
Bicycles	0	0	0		0	0	0		0	0	0		0	0	0		0	
Scoters																		

Comments:

LOCATION: N College St -- Deskins St
CITY/STATE: Newberg, OR

QC JOB #: 16302712
DATE: Thu, Sep 14 2023

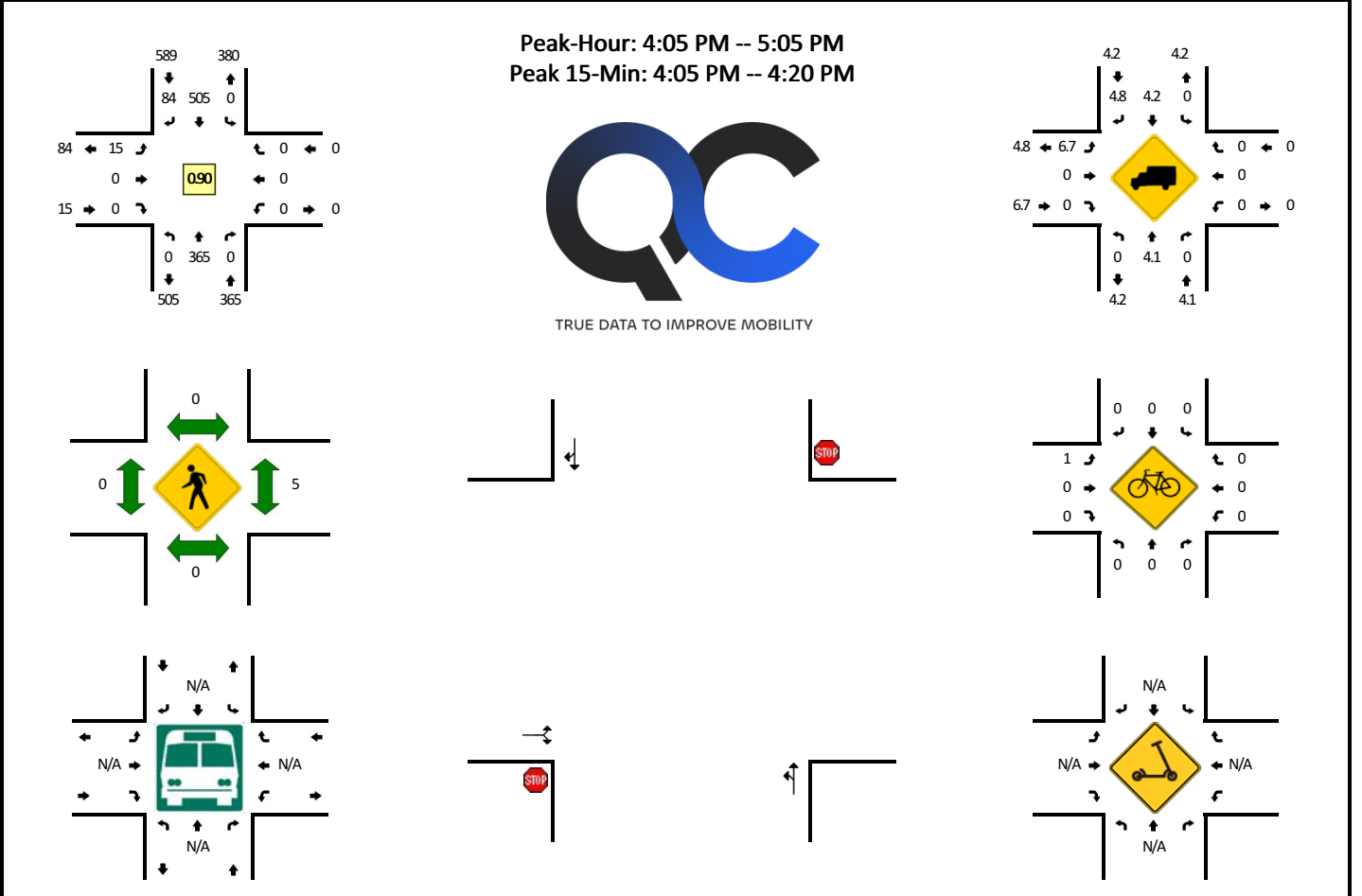

5-Min Count Period Beginning At	N College St (Northbound)				N College St (Southbound)				Deskins St (Eastbound)				Deskins St (Westbound)				Total	Hourly Totals
	Left	Thru	Right	U	Left	Thru	Right	U	Left	Thru	Right	U	Left	Thru	Right	U		
4:00 PM	0	25	0	0	0	33	1	0	2	0	0	0	0	0	0	0	61	
4:05 PM	0	33	0	0	0	51	16	0	0	0	0	0	0	0	0	0	100	
4:10 PM	0	24	0	0	0	48	7	0	2	0	0	0	0	0	0	0	81	
4:15 PM	0	36	0	0	0	49	3	0	0	0	0	0	0	0	0	0	88	
4:20 PM	0	27	0	0	0	43	8	0	0	0	0	0	0	0	0	0	78	
4:25 PM	0	32	0	0	0	58	6	0	2	0	0	0	0	0	0	0	98	
4:30 PM	0	30	0	0	0	39	7	0	1	0	0	0	0	0	0	0	77	
4:35 PM	0	29	0	0	0	45	9	0	1	0	0	0	0	0	0	0	84	
4:40 PM	0	26	0	0	0	41	5	0	2	0	0	0	0	0	0	0	74	
4:45 PM	0	32	0	0	0	40	7	0	1	0	0	0	0	0	0	0	80	
4:50 PM	0	34	0	0	0	23	6	0	1	0	0	0	0	0	0	0	64	
4:55 PM	0	22	0	0	0	38	8	0	3	0	0	0	0	0	0	0	71	956
5:00 PM	0	40	0	0	0	30	2	0	2	0	0	0	0	0	0	0	74	969
5:05 PM	0	29	0	0	0	55	4	0	1	0	0	0	0	0	0	0	89	958
5:10 PM	0	31	0	0	0	30	9	0	0	0	0	0	0	0	0	0	70	947
5:15 PM	0	35	0	0	0	35	9	0	3	0	0	0	0	0	0	0	82	941
5:20 PM	0	33	0	0	0	25	8	0	1	0	0	0	0	0	0	0	67	930
5:25 PM	0	38	0	0	0	31	11	0	1	0	0	0	0	0	0	0	81	913
5:30 PM	0	28	0	0	0	56	2	0	1	0	0	0	0	0	0	0	87	923
5:35 PM	0	35	0	0	0	30	6	0	1	0	0	0	0	0	0	0	72	911
5:40 PM	0	43	0	0	0	32	4	0	0	0	0	0	0	0	0	0	79	916
5:45 PM	0	28	0	0	0	34	8	0	1	0	0	0	0	0	0	0	71	907
5:50 PM	0	26	0	0	0	21	5	0	0	0	0	0	0	0	0	0	52	895
5:55 PM	0	27	0	0	0	25	9	0	1	0	0	0	0	0	0	0	62	886
Peak 15-Min Flowrates	Northbound				Southbound				Eastbound				Westbound				Total	
	Left	Thru	Right	U	Left	Thru	Right	U	Left	Thru	Right	U	Left	Thru	Right	U		
All Vehicles	0	372	0	0	0	592	104	0	8	0	0	0	0	0	0	0	1076	
Heavy Trucks	0	12	0	0	0	28	12	0	4	0	0	0	0	0	0	0	56	
Buses	0	0	0	0	0	0	0	0	0	0	0	0	0	0	0	0	0	
Pedestrians	0	0	0	0	0	0	0	0	0	0	0	0	4	0	0	0	4	
Bicycles	0	0	0	0	0	0	0	0	0	0	0	0	0	0	0	0	0	
Scoters	0	0	0	0	0	0	0	0	0	0	0	0	0	0	0	0	0	

Comments:

LOCATION: Deskins St -- E Illinois St
CITY/STATE: Newberg, OR

QC JOB #: 16302713
DATE: Thu, Sep 14 2023

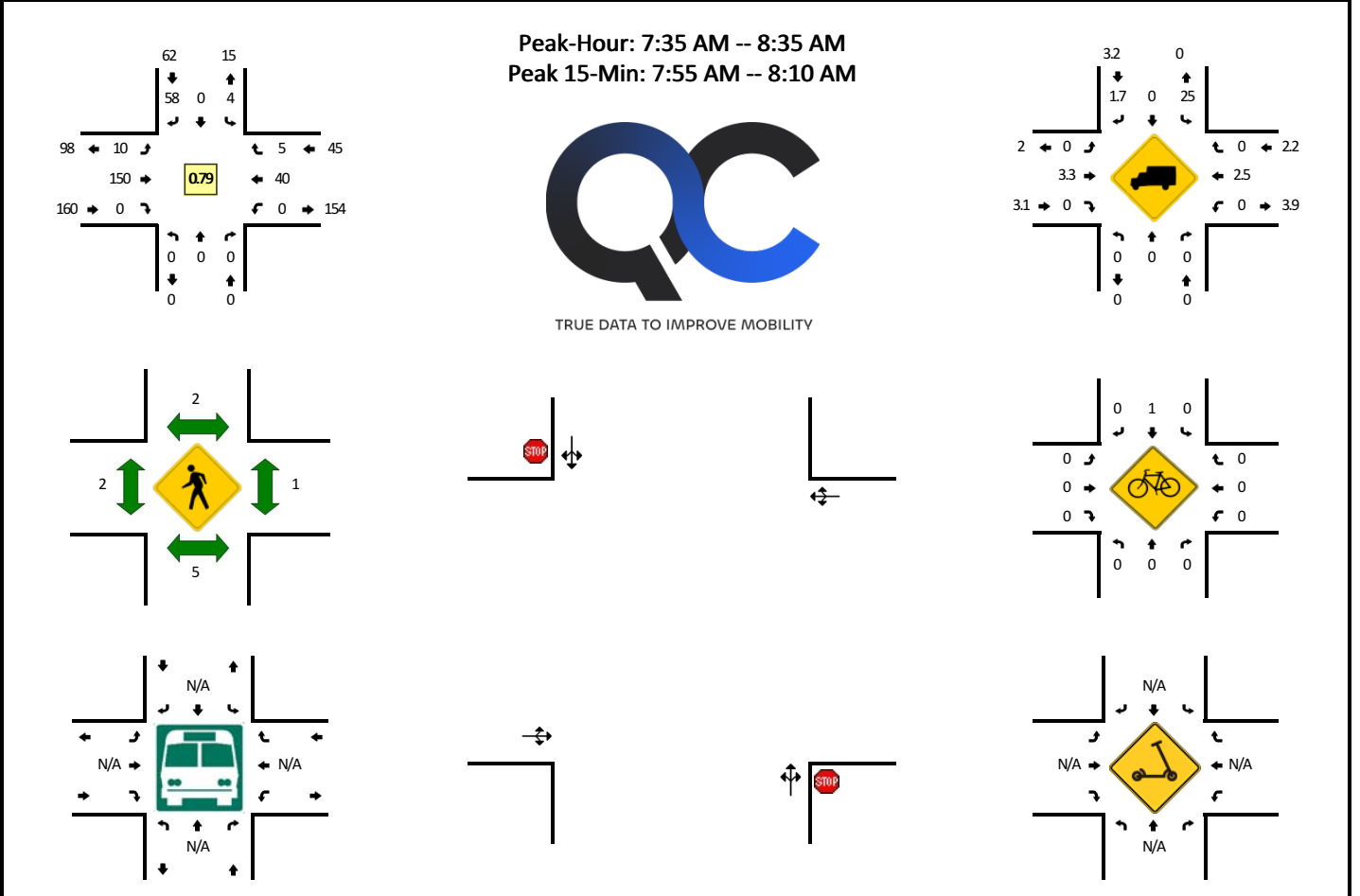

5-Min Count Period Beginning At	Deskins St (Northbound)				Deskins St (Southbound)				E Illinois St (Eastbound)				E Illinois St (Westbound)				Total	Hourly Totals	
	Left	Thru	Right	U	Left	Thru	Right	U	Left	Thru	Right	U	Left	Thru	Right	U			
7:00 AM	0	0	0	0	0	0	2	0	1	10	0	0	0	2	0	0	0	15	
7:05 AM	0	0	0	0	1	0	3	0	0	4	0	0	0	0	0	0	0	8	
7:10 AM	0	0	0	0	0	0	3	0	3	8	0	0	0	2	0	0	0	16	
7:15 AM	0	0	0	0	0	0	4	0	0	9	0	0	0	4	0	0	0	17	
7:20 AM	0	0	0	0	0	0	3	0	0	8	0	0	0	0	0	0	0	11	
7:25 AM	0	0	0	0	0	0	3	0	0	9	0	0	0	3	1	0	0	16	
7:30 AM	0	0	0	0	0	0	7	0	1	3	0	0	0	4	1	0	0	16	
7:35 AM	0	0	0	0	0	0	5	0	0	9	0	0	0	5	1	0	0	20	
7:40 AM	0	0	0	0	0	0	5	0	0	15	0	0	0	1	0	0	0	21	
7:45 AM	0	0	0	0	0	0	3	0	2	14	0	0	0	3	1	0	0	23	
7:50 AM	0	0	0	0	0	0	3	0	0	20	0	0	0	0	1	0	0	24	
7:55 AM	0	0	0	0	0	0	4	0	0	18	0	0	0	4	0	0	0	26	213
8:00 AM	0	0	0	0	2	0	9	0	0	18	0	0	0	2	1	0	0	32	230
8:05 AM	0	0	0	0	1	0	4	0	1	17	0	0	0	3	1	0	0	27	249
8:10 AM	0	0	0	0	0	0	4	0	3	11	0	0	0	7	0	0	0	25	258
8:15 AM	0	0	0	0	0	0	3	0	2	7	0	0	0	5	0	0	0	17	258
8:20 AM	0	0	0	0	1	0	3	0	1	8	0	0	0	6	0	0	0	19	266
8:25 AM	0	0	0	0	0	0	7	0	1	6	0	0	0	2	0	0	0	16	266
8:30 AM	0	0	0	0	0	0	8	0	0	7	0	0	0	2	0	0	0	17	267
8:35 AM	0	0	0	0	0	0	4	0	1	5	0	0	0	0	0	0	0	10	257
8:40 AM	0	0	0	0	0	0	2	0	0	6	0	0	0	2	1	0	0	11	247
8:45 AM	0	0	0	0	0	0	5	0	0	7	0	0	0	1	0	0	0	13	237
8:50 AM	0	0	0	0	0	0	9	0	1	10	0	0	0	2	0	0	0	22	235
8:55 AM	0	0	0	0	0	0	4	0	0	17	0	0	0	2	0	0	0	23	232
Peak 15-Min Flowrates	Northbound				Southbound				Eastbound				Westbound				Total		
	Left	Thru	Right	U	Left	Thru	Right	U	Left	Thru	Right	U	Left	Thru	Right	U			
All Vehicles	0	0	0	0	12	0	68	0	4	212	0	0	0	36	8	0	0	340	
Heavy Trucks	0	0	0	0	4	0	0	0	0	4	0	0	0	0	0	0	0	8	
Buses																			
Pedestrians		12				4				4				0				20	
Bicycles	0	0	0		0	0	0		0	0	0		0	0	0			0	
Scoters																			

Comments:

LOCATION: Deskins St -- E Illinois St
CITY/STATE: Newberg, OR

QC JOB #: 16302714
DATE: Thu, Sep 14 2023

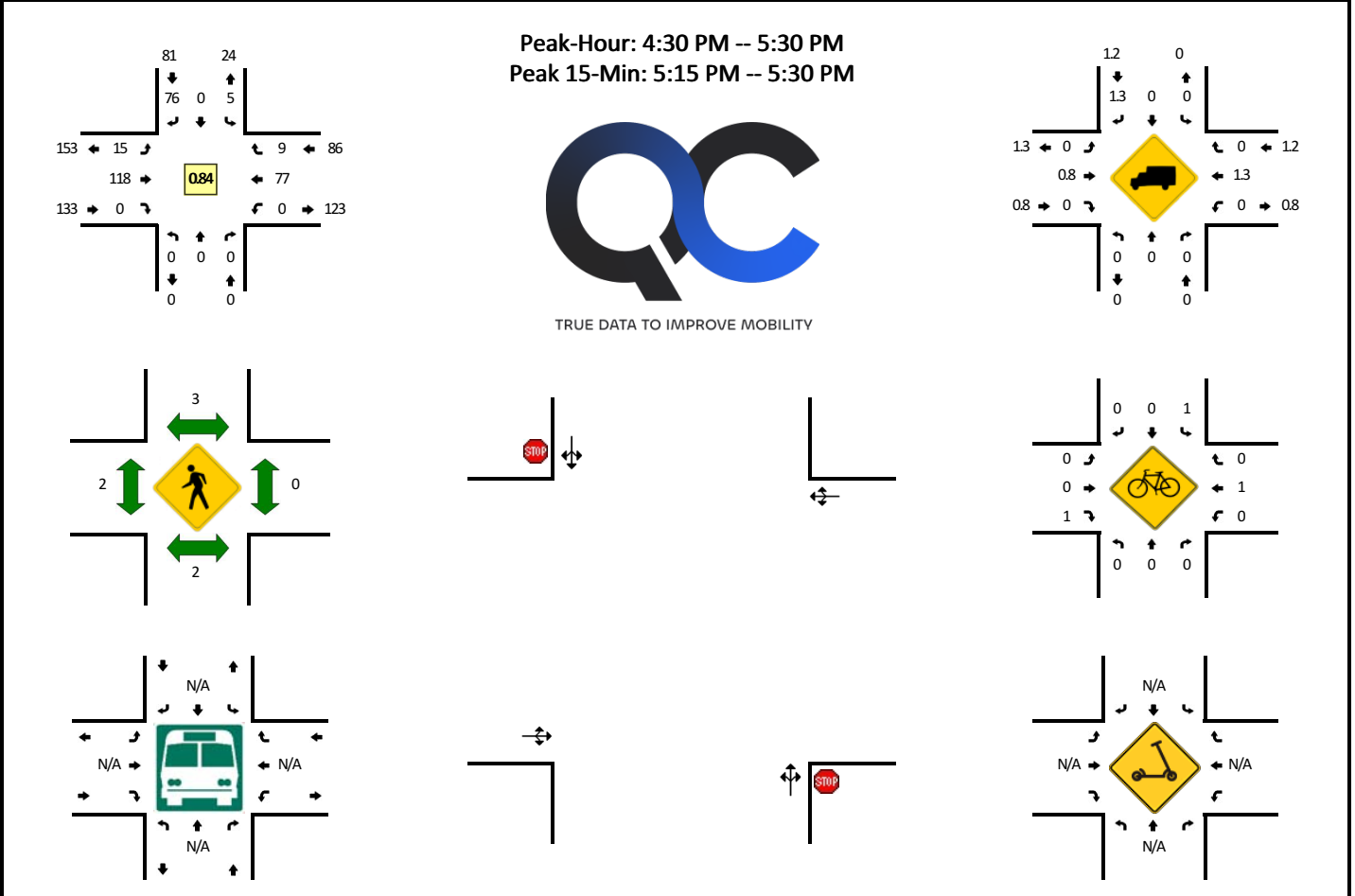

5-Min Count Period Beginning At	Deskins St (Northbound)				Deskins St (Southbound)				E Illinois St (Eastbound)				E Illinois St (Westbound)				Total	Hourly Totals	
	Left	Thru	Right	U	Left	Thru	Right	U	Left	Thru	Right	U	Left	Thru	Right	U			
4:00 PM	0	0	0	0	0	0	1	0	1	6	0	0	0	1	0	0	0	9	
4:05 PM	0	0	0	0	0	0	14	0	0	8	0	0	0	0	9	0	0	31	
4:10 PM	0	0	0	0	0	0	6	0	1	5	0	0	0	0	6	0	0	18	
4:15 PM	0	0	0	0	0	0	3	0	0	7	0	0	0	0	4	0	0	14	
4:20 PM	0	0	0	0	0	0	7	0	1	7	0	0	0	0	7	0	0	22	
4:25 PM	0	0	0	0	0	0	5	0	2	6	0	0	0	0	11	1	0	25	
4:30 PM	0	0	0	0	1	0	6	0	0	8	0	0	0	0	4	0	0	19	
4:35 PM	0	0	0	0	1	0	9	0	1	10	0	0	0	0	6	2	0	29	
4:40 PM	0	0	0	0	0	0	4	0	2	8	0	0	0	0	4	1	0	19	
4:45 PM	0	0	0	0	1	0	5	0	0	8	0	0	0	0	6	1	0	21	
4:50 PM	0	0	0	0	0	0	6	0	2	13	0	0	0	0	7	0	0	28	
4:55 PM	0	0	0	0	0	0	6	0	4	15	0	0	0	0	5	0	0	30	265
5:00 PM	0	0	0	0	0	0	2	0	0	11	0	0	0	0	10	1	0	24	280
5:05 PM	0	0	0	0	1	0	3	0	1	7	0	0	0	0	7	0	0	19	268
5:10 PM	0	0	0	0	0	0	7	0	1	7	0	0	0	0	6	1	0	22	272
5:15 PM	0	0	0	0	0	0	9	0	3	11	0	0	0	0	10	1	0	34	292
5:20 PM	0	0	0	0	0	0	9	0	0	12	0	0	0	0	6	0	0	27	297
5:25 PM	0	0	0	0	1	0	10	0	1	8	0	0	0	0	6	2	0	28	300
5:30 PM	0	0	0	0	1	0	1	0	0	9	0	0	0	0	5	2	0	18	299
5:35 PM	0	0	0	0	0	0	6	0	1	8	0	0	0	0	5	0	0	20	290
5:40 PM	0	0	0	0	0	0	4	0	0	10	0	0	0	0	2	1	0	17	288
5:45 PM	0	0	0	0	0	0	8	0	1	7	0	0	0	0	4	0	0	20	287
5:50 PM	0	0	0	0	0	0	5	0	1	3	0	0	0	0	5	1	0	15	274
5:55 PM	0	0	0	0	0	0	10	0	0	8	0	0	0	0	4	0	0	22	266
Peak 15-Min Flowrates	Northbound				Southbound				Eastbound				Westbound				Total		
	Left	Thru	Right	U	Left	Thru	Right	U	Left	Thru	Right	U	Left	Thru	Right	U			
All Vehicles	0	0	0	0	4	0	112	0	16	124	0	0	0	88	12	0	0	356	
Heavy Trucks	0	0	0	0	0	0	4	0	0	0	0	0	0	0	0	0	0	4	
Buses																			
Pedestrians		4				0				4				0				8	
Bicycles	0	0	0		0	0	0		0	0	0		0	0	0			0	
Scoters																			

Comments:

LOCATION: N College St -- E Illinois St
CITY/STATE: Newberg, OR

QC JOB #: 16302715
DATE: Thu, Sep 14 2023

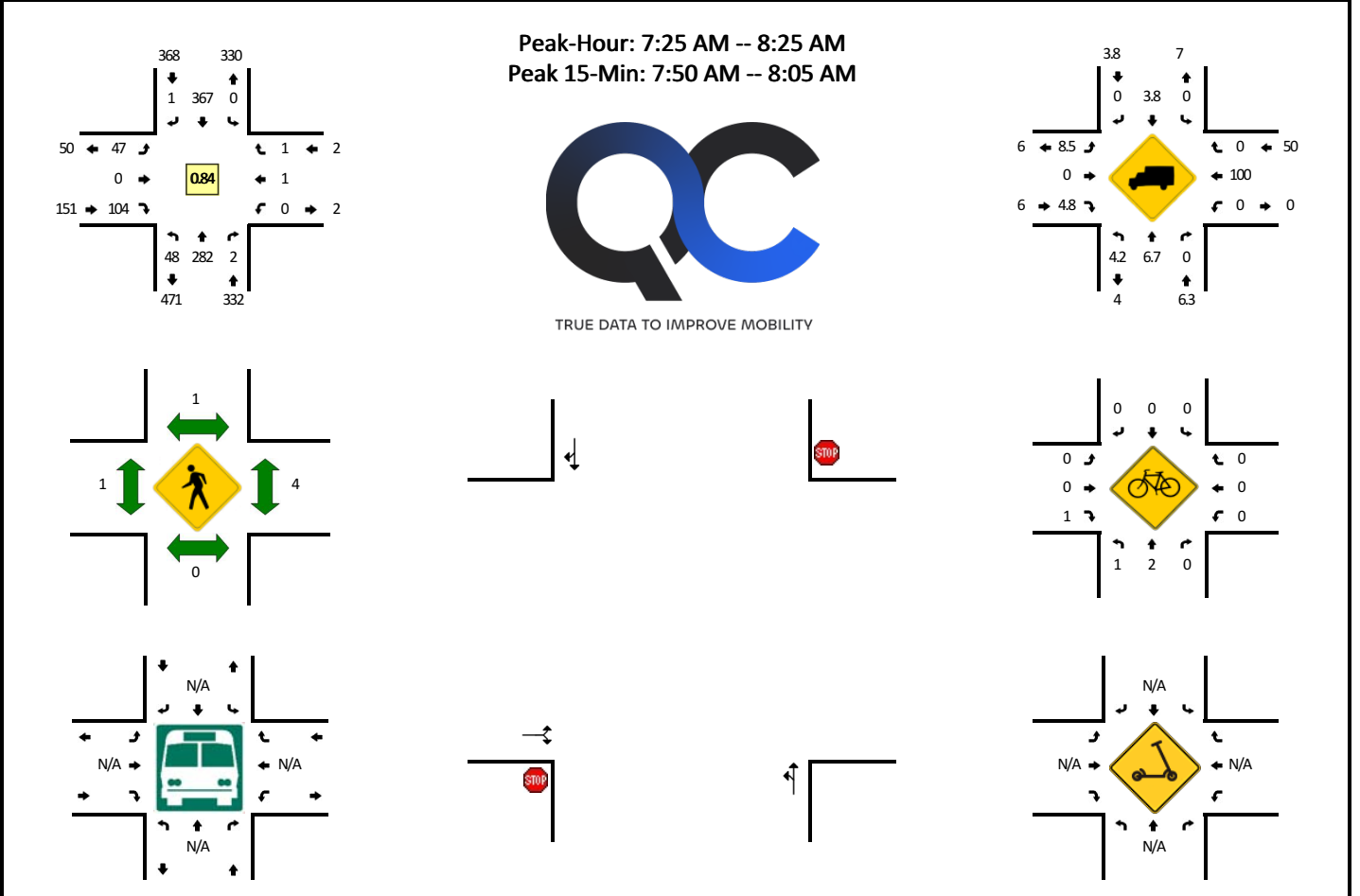

5-Min Count Period Beginning At	N College St (Northbound)				N College St (Southbound)				E Illinois St (Eastbound)				E Illinois St (Westbound)				Total	Hourly Totals
	Left	Thru	Right	U	Left	Thru	Right	U	Left	Thru	Right	U	Left	Thru	Right	U		
7:00 AM	2	16	0	0	0	26	0	0	4	0	5	0	0	0	0	0	53	
7:05 AM	0	12	0	0	0	23	0	0	0	0	6	0	0	0	0	0	41	
7:10 AM	2	15	0	0	0	16	0	0	3	0	5	0	0	0	0	0	41	
7:15 AM	4	25	0	0	0	23	0	0	2	0	7	0	0	0	0	0	61	
7:20 AM	0	18	0	0	0	24	0	0	2	0	6	0	0	0	0	0	50	
7:25 AM	4	22	0	0	0	24	0	0	6	0	2	0	0	0	0	0	58	
7:30 AM	5	15	0	0	0	35	0	0	1	0	3	0	0	0	0	0	59	
7:35 AM	6	24	0	0	0	24	0	0	5	0	4	0	0	0	0	0	63	
7:40 AM	1	19	0	0	0	33	0	0	4	0	11	0	0	0	0	0	68	
7:45 AM	4	37	0	0	0	32	0	0	5	0	7	0	0	0	0	0	85	
7:50 AM	1	30	0	0	0	35	0	0	6	0	14	0	0	0	0	0	86	
7:55 AM	3	25	0	0	0	31	1	0	1	0	16	0	0	0	0	0	77	742
8:00 AM	3	25	1	0	0	39	0	0	3	0	19	0	0	0	0	0	90	779
8:05 AM	4	25	0	0	0	24	0	0	7	0	9	0	0	0	0	0	69	807
8:10 AM	6	20	0	0	0	29	0	0	3	0	7	0	0	1	0	0	66	832
8:15 AM	6	16	0	0	0	39	0	0	2	0	7	0	0	0	0	0	70	841
8:20 AM	5	24	1	0	0	22	0	0	4	0	5	0	0	0	1	0	62	853
8:25 AM	2	12	0	0	0	33	0	0	2	0	4	0	0	0	0	0	53	848
8:30 AM	2	15	0	0	0	21	0	0	3	0	4	0	0	0	0	0	45	834
8:35 AM	0	7	0	0	0	18	0	0	3	0	2	0	0	0	0	0	30	801
8:40 AM	3	23	0	0	0	12	0	0	2	0	4	0	0	0	0	0	44	777
8:45 AM	1	18	0	0	0	30	0	0	2	0	5	0	0	0	0	0	56	748
8:50 AM	2	9	0	0	0	27	0	0	3	0	7	0	0	0	0	0	48	710
8:55 AM	2	16	0	0	0	11	0	0	4	0	11	0	0	0	0	0	44	677
Peak 15-Min Flowrates	Northbound				Southbound				Eastbound				Westbound				Total	
	Left	Thru	Right	U	Left	Thru	Right	U	Left	Thru	Right	U	Left	Thru	Right	U		
All Vehicles	28	320	4	0	0	420	4	0	40	0	196	0	0	0	0	0	1012	
Heavy Trucks	0	24	0	0	0	12	0	0	4	0	12	0	0	0	0	0	52	
Buses																		
Pedestrians	4	0	0			4				4				4			12	
Bicycles						0				0				0			4	
Scoters																		

Comments:

LOCATION: N College St -- E Illinois St
CITY/STATE: Newberg, OR

QC JOB #: 16302716
DATE: Thu, Sep 14 2023

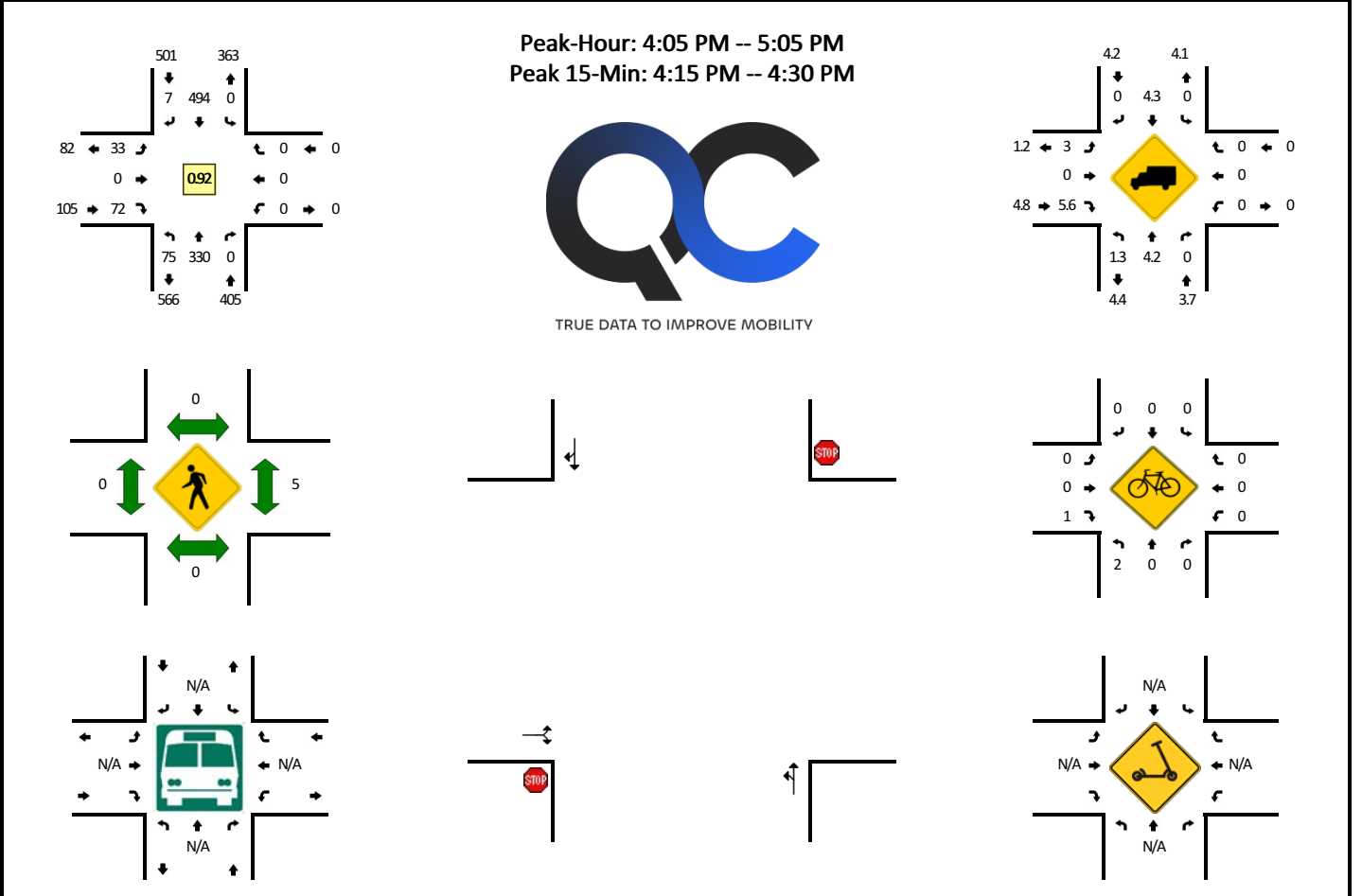

5-Min Count Period Beginning At	N College St (Northbound)				N College St (Southbound)				E Illinois St (Eastbound)				E Illinois St (Westbound)				Total	Hourly Totals
	Left	Thru	Right	U	Left	Thru	Right	U	Left	Thru	Right	U	Left	Thru	Right	U		
4:00 PM	1	24	0	0	0	34	0	0	2	0	4	0	0	0	0	0	65	
4:05 PM	7	28	0	0	0	48	2	0	4	0	4	0	0	0	0	0	93	
4:10 PM	5	23	0	0	0	48	1	0	1	0	4	0	0	0	0	0	82	
4:15 PM	4	34	0	0	0	49	0	0	3	0	4	0	0	0	0	0	94	
4:20 PM	7	25	0	0	0	42	0	0	1	0	3	0	0	0	0	0	78	
4:25 PM	9	29	0	0	0	57	0	0	3	0	5	0	0	0	0	0	103	
4:30 PM	4	30	0	0	0	39	0	0	1	0	8	0	0	0	0	0	82	
4:35 PM	7	24	0	0	0	41	1	0	2	0	6	0	0	0	0	0	81	
4:40 PM	3	25	0	0	0	41	2	0	3	0	5	0	0	0	0	0	79	
4:45 PM	7	27	0	0	0	41	0	0	3	0	6	0	0	0	0	0	84	
4:50 PM	6	30	0	0	0	21	1	0	4	0	9	0	0	0	0	0	71	
4:55 PM	5	18	0	0	0	38	0	0	4	0	11	0	0	0	0	0	76	988
5:00 PM	11	37	0	0	0	29	0	0	4	0	7	0	0	0	0	0	88	1011
5:05 PM	6	24	0	0	0	53	1	0	4	0	4	0	0	0	0	0	92	1010
5:10 PM	7	27	0	0	0	32	0	0	4	0	4	0	0	0	0	0	74	1002
5:15 PM	11	33	0	0	0	35	0	0	3	0	7	0	0	0	0	0	89	997
5:20 PM	5	32	0	0	0	23	1	0	1	0	9	0	0	0	0	0	71	990
5:25 PM	8	28	0	0	0	32	0	0	9	0	3	0	0	0	0	0	80	967
5:30 PM	7	27	0	0	0	55	0	0	3	0	5	0	0	0	0	0	97	982
5:35 PM	5	27	0	0	0	31	0	0	6	0	4	0	0	0	0	0	73	974
5:40 PM	3	38	0	0	0	32	0	0	5	0	5	0	0	0	0	0	83	978
5:45 PM	4	25	0	0	0	34	0	0	4	0	2	0	0	0	0	0	69	963
5:50 PM	6	23	0	0	0	21	0	0	2	0	2	0	0	0	0	0	54	946
5:55 PM	4	25	0	0	0	24	0	0	3	0	4	0	0	0	0	0	60	930
Peak 15-Min Flowrates	Northbound				Southbound				Eastbound				Westbound				Total	
	Left	Thru	Right	U	Left	Thru	Right	U	Left	Thru	Right	U	Left	Thru	Right	U		
All Vehicles	80	352	0	0	0	592	0	0	28	0	48	0	0	0	0	0	1100	
Heavy Trucks	0	12	0	0	0	32	0	0	0	0	8	0	0	0	0	0	52	
Buses																		
Pedestrians	0	0			0	0			0	0			8				8	
Bicycles	0	0			0	0			0	0	0		0	0	0		0	
Scoters																		

Comments:

LOCATION: Hwy 240/N Main St -- E North St
CITY/STATE: Newberg, OR

QC JOB #: 16302717
DATE: Thu, Sep 14 2023

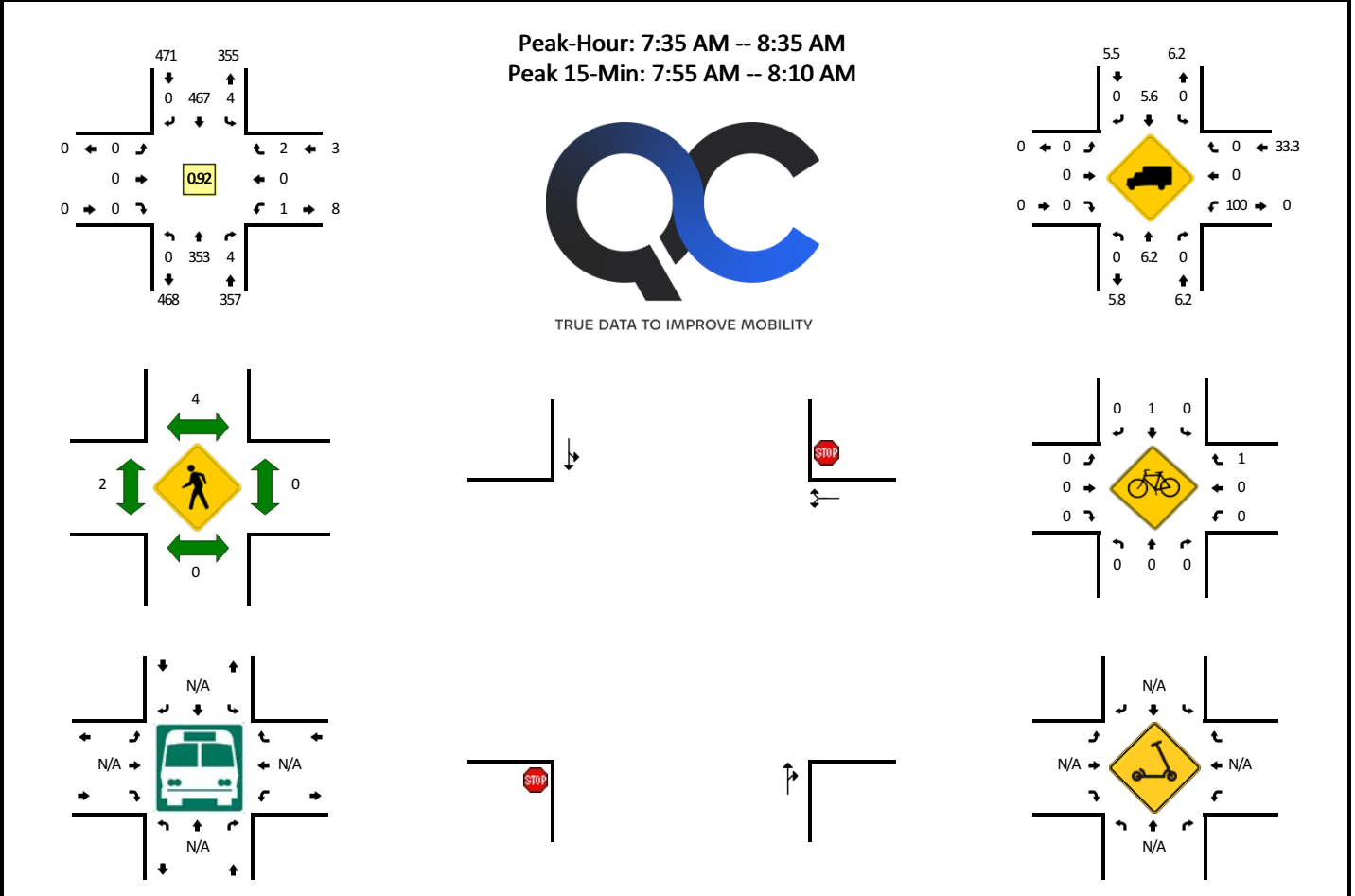

5-Min Count Period Beginning At	Hwy 240/N Main St (Northbound)				Hwy 240/N Main St (Southbound)				E North St (Eastbound)				E North St (Westbound)				Total	Hourly Totals
	Left	Thru	Right	U	Left	Thru	Right	U	Left	Thru	Right	U	Left	Thru	Right	U		
7:00 AM	0	33	0	0	0	26	0	0	0	0	0	0	0	0	0	0	59	
7:05 AM	0	22	0	0	0	35	0	0	0	0	0	0	0	0	0	0	57	
7:10 AM	0	19	0	0	0	40	0	0	0	0	0	0	0	0	0	0	59	
7:15 AM	0	25	0	0	0	37	0	0	0	0	0	0	0	0	0	0	62	
7:20 AM	0	16	1	0	0	43	0	0	0	0	0	0	1	0	1	0	62	
7:25 AM	0	18	0	0	0	38	0	0	0	0	0	0	0	0	0	0	56	
7:30 AM	0	23	0	0	0	30	0	0	0	0	0	0	0	0	1	0	54	
7:35 AM	0	30	1	0	0	50	0	0	0	0	0	0	0	0	0	0	81	
7:40 AM	0	30	0	0	1	34	0	0	0	0	0	0	1	0	0	0	66	
7:45 AM	0	23	0	0	0	50	0	0	0	0	0	0	0	0	0	0	73	
7:50 AM	0	42	1	0	0	35	0	0	0	0	0	0	0	0	0	0	78	
7:55 AM	0	40	0	0	0	31	0	0	0	0	0	0	0	0	0	0	71	778
8:00 AM	0	26	0	0	0	39	0	0	0	0	0	0	0	0	0	0	65	784
8:05 AM	0	41	1	0	1	47	0	0	0	0	0	0	0	0	1	0	91	818
8:10 AM	0	34	0	0	0	34	0	0	0	0	0	0	0	0	1	0	69	828
8:15 AM	0	21	1	0	0	37	0	0	0	0	0	0	0	0	0	0	59	825
8:20 AM	0	18	0	0	0	26	0	0	0	0	0	0	0	0	0	0	44	807
8:25 AM	0	22	0	0	1	49	0	0	0	0	0	0	0	0	0	0	72	823
8:30 AM	0	26	0	0	1	35	0	0	0	0	0	0	0	0	0	0	62	831
8:35 AM	0	25	0	0	0	32	0	0	0	0	0	0	0	0	0	0	57	807
8:40 AM	0	31	0	0	1	25	0	0	0	0	0	0	0	0	0	0	57	798
8:45 AM	0	34	0	0	0	29	0	0	0	0	0	0	0	0	0	0	63	788
8:50 AM	0	30	0	0	0	31	0	0	0	0	0	0	0	0	0	0	61	771
8:55 AM	0	29	1	0	0	36	0	0	0	0	0	0	0	0	1	0	67	767
Peak 15-Min Flowrates	Northbound				Southbound				Eastbound				Westbound				Total	
	Left	Thru	Right	U	Left	Thru	Right	U	Left	Thru	Right	U	Left	Thru	Right	U		
All Vehicles	0	428	4	0	4	468	0	0	0	0	0	0	0	0	4	0	908	
Heavy Trucks	0	28	0	0	0	28	0	0	0	0	0	0	0	0	0	0	56	
Buses																		
Pedestrians	0	0	0	0	0	4	0	0	0	0	0	0	0	0	0	0	4	
Bicycles	0	0	0	0	0	0	0	0	0	0	0	0	0	0	4	0	4	
Scoters																		

Comments:

LOCATION: Hwy 240/N Main St -- E North St
CITY/STATE: Newberg, OR

QC JOB #: 16302718
DATE: Thu, Sep 14 2023

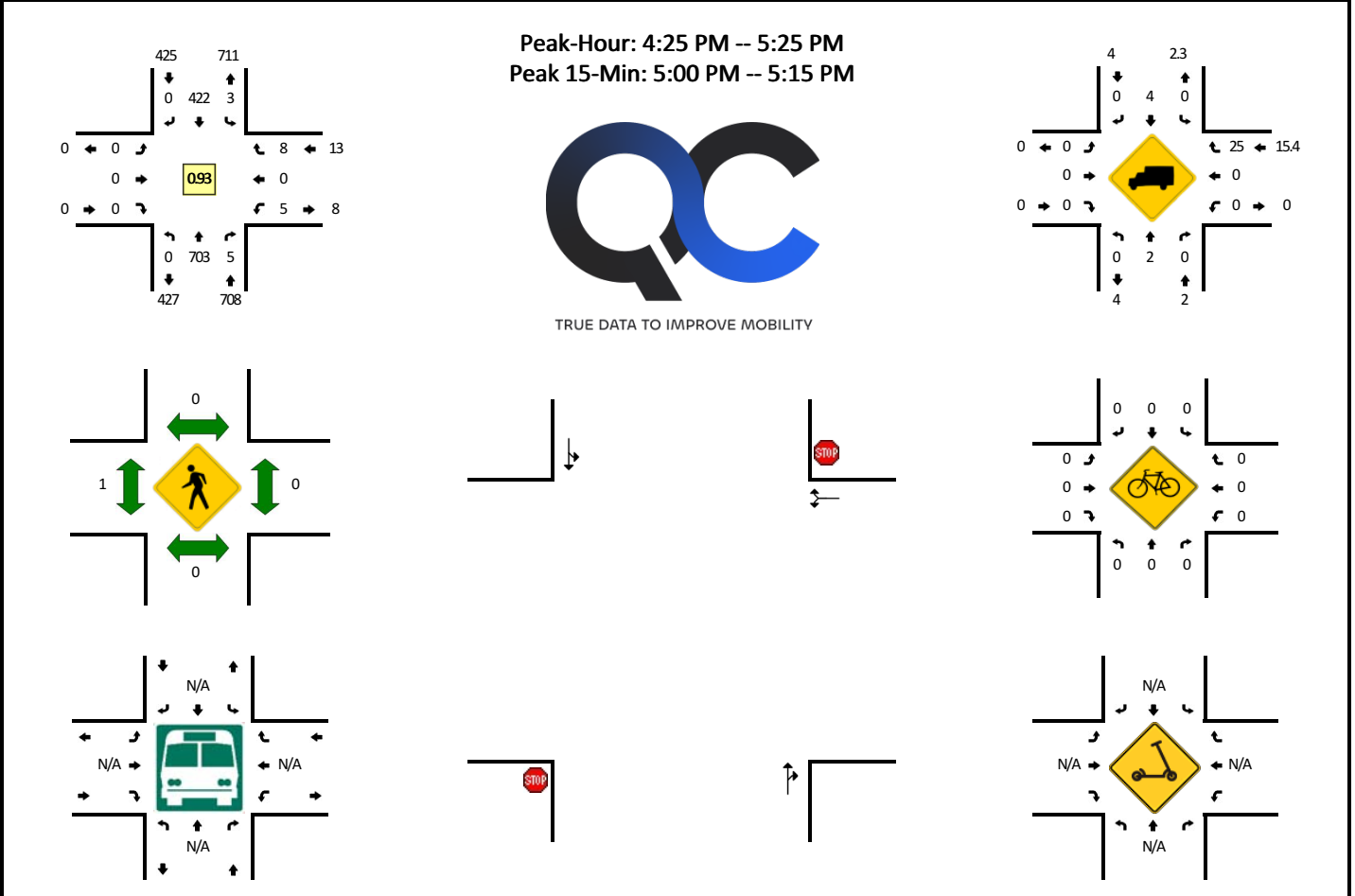

5-Min Count Period Beginning At	Hwy 240/N Main St (Northbound)				Hwy 240/N Main St (Southbound)				E North St (Eastbound)				E North St (Westbound)				Total	Hourly Totals
	Left	Thru	Right	U	Left	Thru	Right	U	Left	Thru	Right	U	Left	Thru	Right	U		
4:00 PM	0	42	0	0	0	30	0	0	0	0	0	0	0	0	0	0	72	
4:05 PM	0	44	0	0	0	43	0	0	0	0	0	0	0	1	0	0	88	
4:10 PM	0	55	0	0	0	34	0	0	0	0	0	0	0	0	0	0	89	
4:15 PM	0	50	0	0	0	36	0	0	0	0	0	0	0	0	0	0	86	
4:20 PM	0	59	1	0	0	33	0	0	0	0	0	0	0	0	0	0	93	
4:25 PM	0	55	0	0	0	44	0	0	0	0	0	0	0	0	0	0	99	
4:30 PM	0	54	0	0	0	33	0	0	0	0	0	0	0	0	0	1	88	
4:35 PM	0	57	2	0	0	29	0	0	0	0	0	0	0	0	0	1	89	
4:40 PM	0	62	0	0	0	42	0	0	0	0	0	0	0	0	0	1	105	
4:45 PM	0	61	0	0	0	36	0	0	0	0	0	0	0	0	0	0	97	
4:50 PM	0	55	0	0	0	33	0	0	0	0	0	0	0	0	0	0	88	
4:55 PM	0	56	2	0	1	22	0	0	0	0	0	0	0	1	0	0	82	1076
5:00 PM	0	66	0	0	1	30	0	0	0	0	0	0	0	2	0	1	100	1104
5:05 PM	0	62	0	0	0	42	0	0	0	0	0	0	0	1	0	2	107	1123
5:10 PM	0	66	1	0	0	32	0	0	0	0	0	0	0	1	0	1	101	1135
5:15 PM	0	61	0	0	1	34	0	0	0	0	0	0	0	0	0	0	96	1145
5:20 PM	0	48	0	0	0	45	0	0	0	0	0	0	0	0	0	1	94	1146
5:25 PM	0	55	0	0	0	39	0	0	0	0	0	0	0	1	0	1	96	1143
5:30 PM	0	52	0	0	0	37	0	0	0	0	0	0	0	0	0	0	89	1144
5:35 PM	0	60	0	0	0	26	0	0	0	0	0	0	0	0	0	0	86	1141
5:40 PM	0	44	0	0	0	33	0	0	0	0	0	0	0	0	0	0	77	1113
5:45 PM	0	57	0	0	0	42	0	0	0	0	0	0	0	0	0	0	99	1115
5:50 PM	0	47	1	0	0	43	0	0	0	0	0	0	0	0	0	1	92	1119
5:55 PM	0	44	0	0	0	35	0	0	0	0	0	0	0	0	0	0	79	1116
Peak 15-Min Flowrates	Northbound				Southbound				Eastbound				Westbound				Total	
	Left	Thru	Right	U	Left	Thru	Right	U	Left	Thru	Right	U	Left	Thru	Right	U		
All Vehicles	0	776	4	0	4	416	0	0	0	0	0	0	16	0	16	0	1232	
Heavy Trucks	0	12	0	0	0	20	0	0	0	0	0	0	0	0	8	0	40	
Buses																		
Pedestrians	0	0			0	0			0	0			0	0			0	
Bicycles	0	0			0	0			0	0			0	0			0	
Scoters																		

Comments:

LOCATION: N Main St -- E Pinehurst Dr
CITY/STATE: Newberg, OR

QC JOB #: 16302719
DATE: Sat, Sep 16 2023

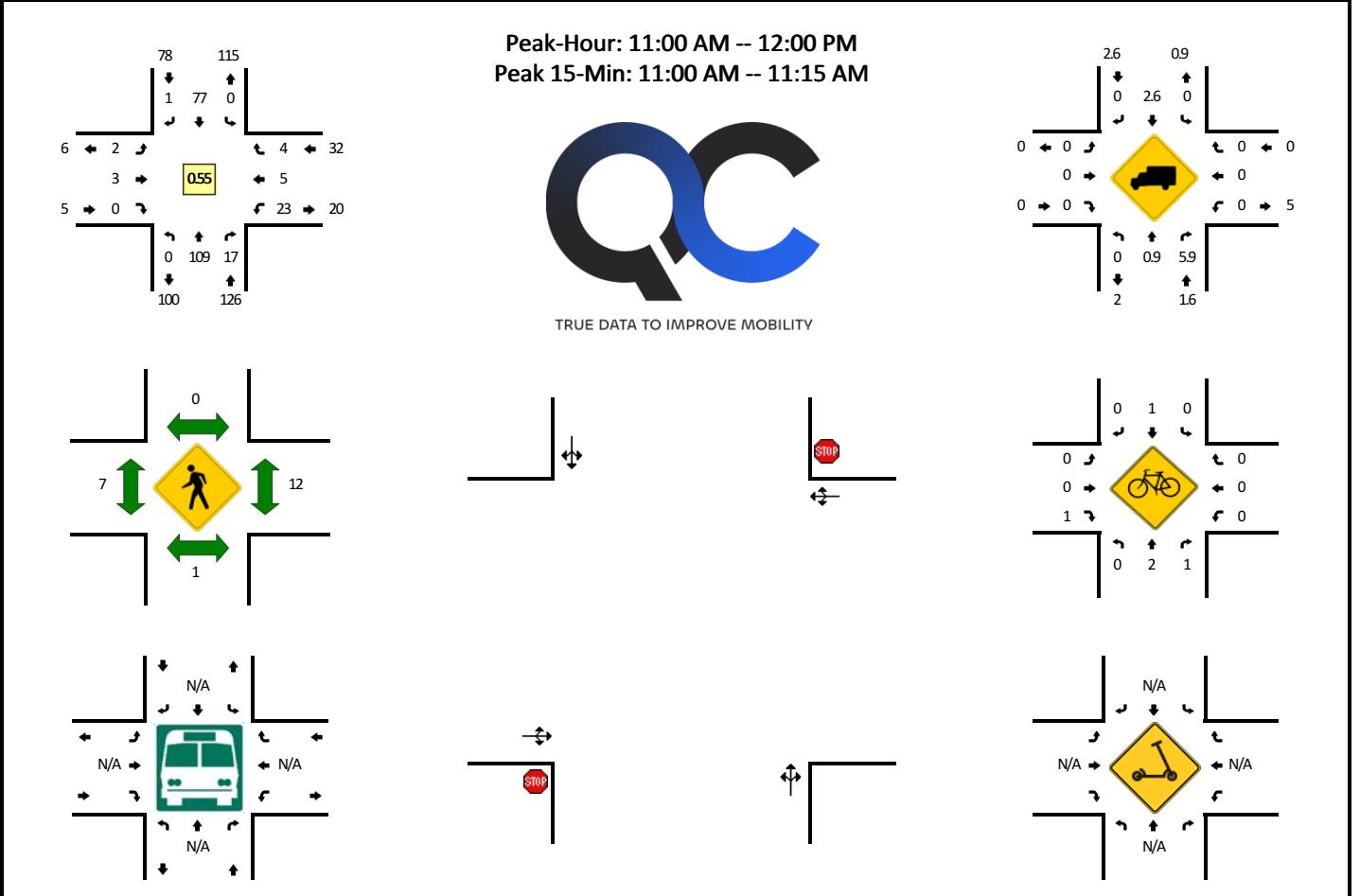

5-Min Count Period Beginning At	N Main St (Northbound)				N Main St (Southbound)				E Pinehurst Dr (Eastbound)				E Pinehurst Dr (Westbound)				Total	Hourly Totals
	Left	Thru	Right	U	Left	Thru	Right	U	Left	Thru	Right	U	Left	Thru	Right	U		
11:00 AM	0	17	3	0	0	15	0	0	1	1	0	0	7	1	0	0	45	
11:05 AM	0	18	5	0	0	13	0	0	0	0	0	0	6	0	0	0	42	
11:10 AM	0	10	2	0	0	5	0	0	0	0	0	0	5	0	0	0	22	
11:15 AM	0	17	1	0	0	6	1	0	0	1	0	0	0	0	3	0	29	
11:20 AM	0	5	2	0	0	8	0	0	0	0	0	0	0	0	0	0	15	
11:25 AM	0	6	1	0	0	3	0	0	0	0	0	0	1	0	0	0	11	
11:30 AM	0	2	0	0	0	3	0	0	0	0	0	0	1	1	0	0	7	
11:35 AM	0	6	0	0	0	8	0	0	0	0	0	0	0	1	0	0	15	
11:40 AM	0	3	2	0	0	4	0	0	1	0	0	0	1	0	1	0	12	
11:45 AM	0	6	0	0	0	5	0	0	0	0	0	0	0	2	0	0	13	
11:50 AM	0	10	0	0	0	4	0	0	0	1	0	0	0	0	0	0	15	
11:55 AM	0	9	1	0	0	3	0	0	0	0	0	0	2	0	0	0	15	241
12:00 PM	0	8	1	0	0	3	1	0	0	0	1	0	1	0	0	0	15	211
12:05 PM	0	5	0	0	0	7	0	0	0	0	1	0	0	0	0	0	13	182
12:10 PM	0	4	0	0	0	5	0	0	0	0	0	0	1	0	0	0	10	170
12:15 PM	1	9	1	0	1	3	0	0	0	0	0	0	0	0	0	0	15	156
12:20 PM	0	17	4	0	1	7	0	0	0	0	0	0	1	0	0	0	30	171
12:25 PM	1	21	5	0	0	1	0	0	1	0	0	0	0	0	0	0	29	189
12:30 PM	0	10	4	0	1	5	0	0	0	0	0	0	2	0	0	0	22	204
12:35 PM	0	8	1	0	1	2	0	0	0	0	0	0	0	0	0	0	12	201
12:40 PM	0	5	1	0	1	4	0	0	0	0	0	0	0	0	0	0	11	200
12:45 PM	0	6	0	0	0	5	0	0	0	0	0	0	1	0	2	0	14	201
12:50 PM	0	6	0	0	0	3	0	0	0	0	1	0	2	1	0	0	13	199
12:55 PM	0	7	4	0	0	4	0	0	0	0	1	0	0	1	0	0	17	201

Peak 15-Min Flowrates	Northbound				Southbound				Eastbound				Westbound				Total
	Left	Thru	Right	U	Left	Thru	Right	U	Left	Thru	Right	U	Left	Thru	Right	U	
All Vehicles	0	180	40	0	0	132	0	0	4	4	0	0	72	4	0	0	436
Heavy Trucks	0	0	0	0	0	8	0	0	0	0	0	0	0	0	0	0	8
Buses																	
Pedestrians	0	0	0	0	0	0	0	0	0	16	0	0	28	0	0	0	44
Bicycles	0	0	0	0	0	0	0	0	0	0	4	0	0	0	0	0	4
Scoters																	

Comments:

LOCATION: N College St -- E Pinehurst Dr
CITY/STATE: Newberg, OR

QC JOB #: 16302720
DATE: Sat, Sep 16 2023

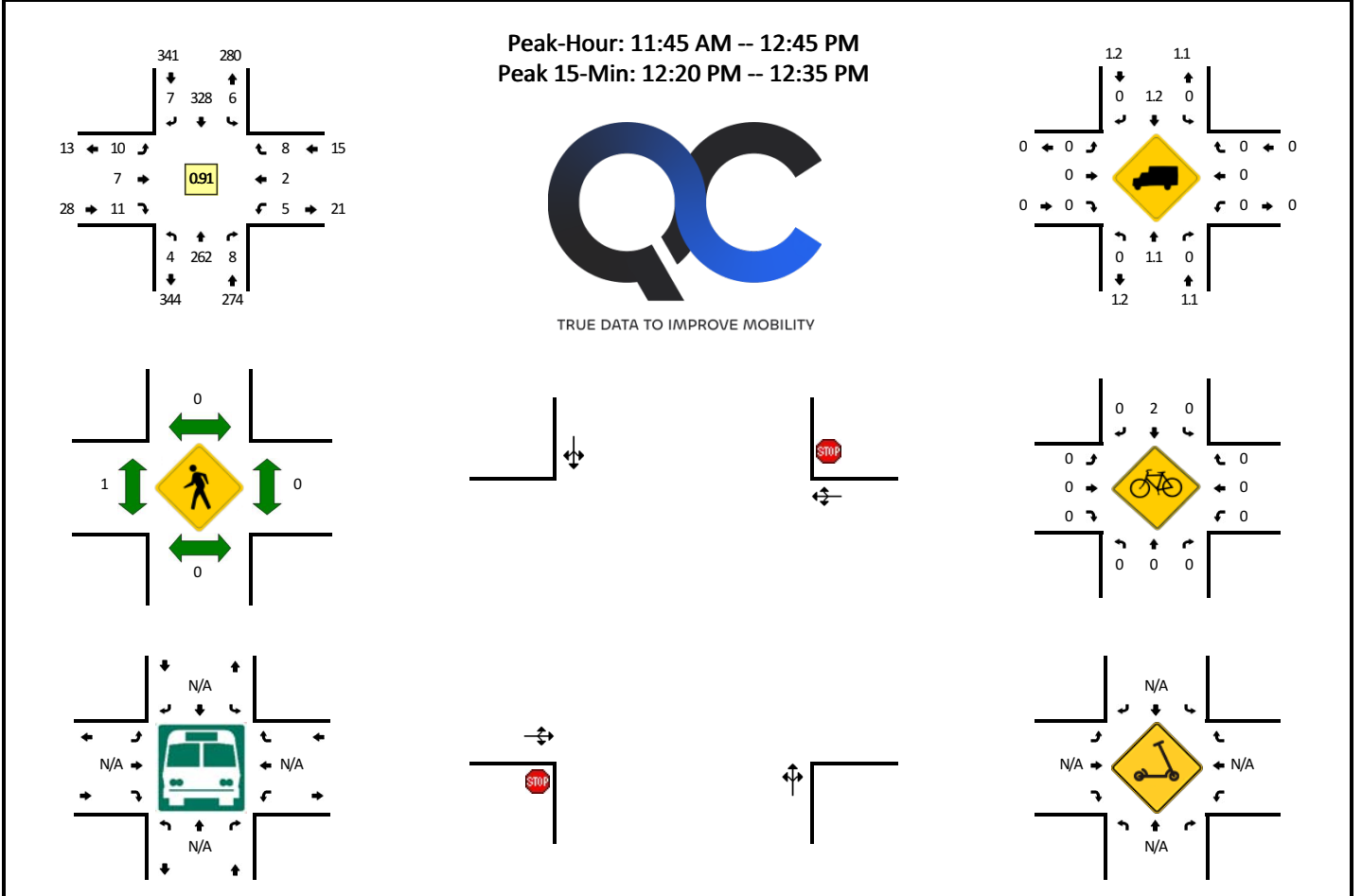

5-Min Count Period Beginning At	N College St (Northbound)				N College St (Southbound)				E Pinehurst Dr (Eastbound)				E Pinehurst Dr (Westbound)				Total	Hourly Totals
	Left	Thru	Right	U	Left	Thru	Right	U	Left	Thru	Right	U	Left	Thru	Right	U		
11:00 AM	2	19	0	0	0	24	5	0	0	2	2	0	1	0	0	0	55	
11:05 AM	1	22	3	0	0	34	3	0	2	0	3	0	0	1	1	0	70	
11:10 AM	2	23	1	0	1	24	2	0	1	1	3	0	0	1	0	0	59	
11:15 AM	1	16	0	0	0	25	0	0	0	0	4	0	0	1	1	0	48	
11:20 AM	0	20	0	0	1	18	0	0	2	0	2	0	0	0	0	0	43	
11:25 AM	0	19	1	0	0	27	0	0	1	0	0	0	1	0	0	0	49	
11:30 AM	1	20	0	0	1	31	1	0	0	0	0	0	1	0	0	0	55	
11:35 AM	0	21	0	0	1	20	1	0	1	0	1	0	0	1	0	0	46	
11:40 AM	2	18	0	0	0	30	2	0	1	0	2	0	1	0	1	0	57	
11:45 AM	0	24	1	0	0	25	0	0	0	0	1	0	0	1	1	0	53	
11:50 AM	1	21	0	0	0	34	0	0	0	1	0	0	1	0	1	0	59	
11:55 AM	0	24	0	0	1	25	1	0	1	0	0	0	0	0	1	0	53	647
12:00 PM	0	21	0	0	1	27	2	0	1	0	0	0	0	0	0	0	52	644
12:05 PM	0	19	1	0	0	31	0	0	0	1	0	0	0	0	1	0	53	627
12:10 PM	0	18	2	0	0	17	1	0	1	0	1	0	0	0	2	0	42	610
12:15 PM	2	19	1	0	0	28	1	0	0	1	0	0	1	0	0	0	53	615
12:20 PM	1	20	1	0	1	21	0	0	3	0	1	0	0	0	0	0	48	620
12:25 PM	0	27	0	0	0	37	1	0	1	3	2	0	0	0	0	0	71	642
12:30 PM	0	21	0	0	2	32	1	0	1	0	3	0	2	0	0	0	62	649
12:35 PM	0	20	1	0	0	24	0	0	1	0	0	0	1	0	1	0	48	651
12:40 PM	0	28	1	0	1	27	0	0	1	1	3	0	0	1	1	0	64	658
12:45 PM	1	13	1	0	1	24	0	0	0	1	0	0	0	0	0	0	41	646
12:50 PM	1	18	1	0	0	32	0	0	0	0	0	0	0	2	1	0	55	642
12:55 PM	2	20	1	0	1	28	0	0	1	1	1	0	0	0	1	0	56	645
Peak 15-Min Flowrates	Northbound				Southbound				Eastbound				Westbound				Total	
	Left	Thru	Right	U	Left	Thru	Right	U	Left	Thru	Right	U	Left	Thru	Right	U		
All Vehicles	4	272	4	0	12	360	8	0	20	12	24	0	8	0	0	0	724	
Heavy Trucks	0	4	0		0	4	0		0	0	0		0	0	0		8	
Buses																		
Pedestrians	0	0			0	0			0	0			0	0			0	
Bicycles	0	0			0	0			0	0			0	0			0	
Scoters																		

Comments:

LOCATION: N Main St -- Hwy 240
CITY/STATE: Newberg, OR

QC JOB #: 16302721
DATE: Sat, Sep 16 2023

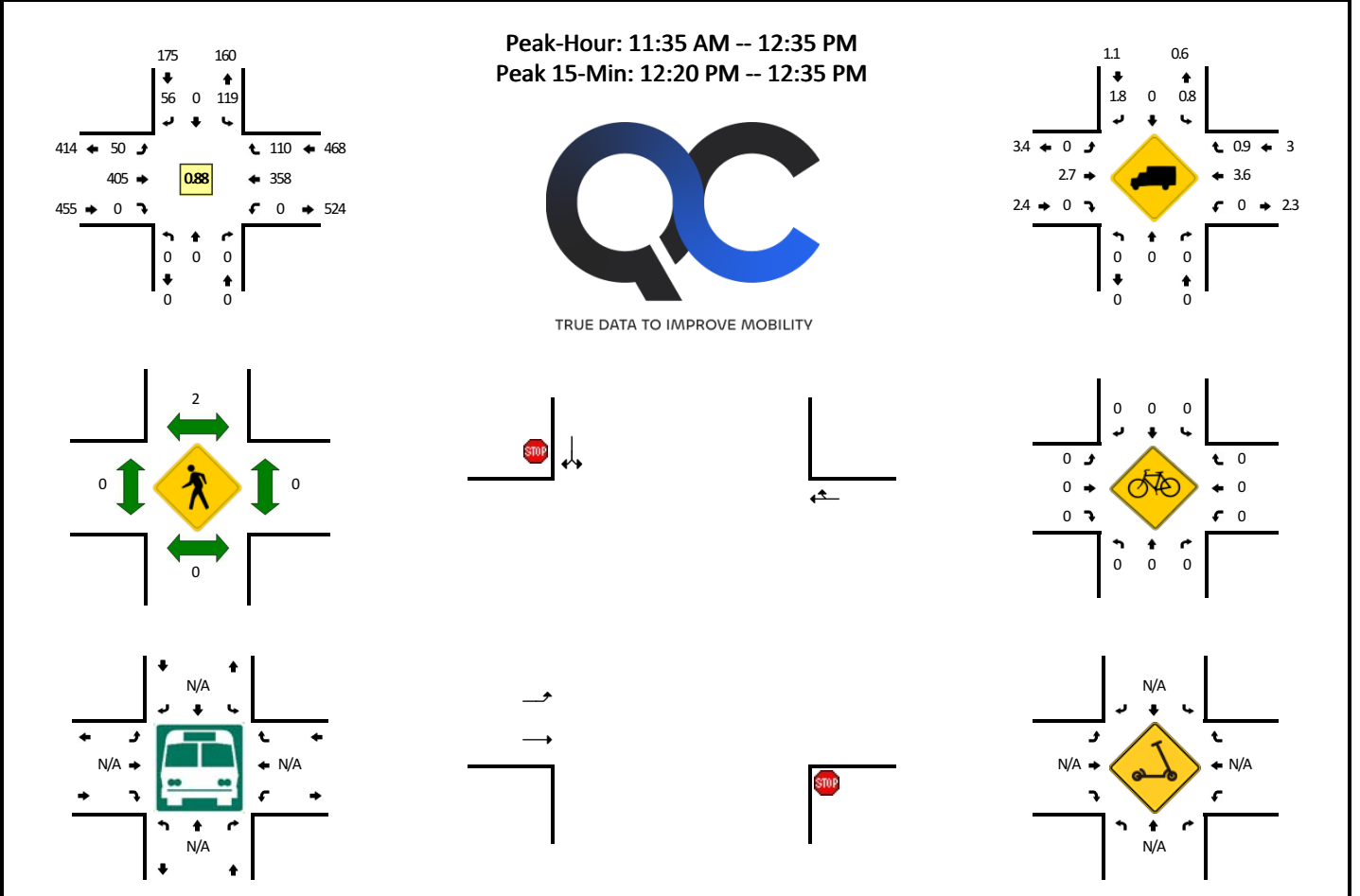

5-Min Count Period Beginning At	N Main St (Northbound)				N Main St (Southbound)				Hwy 240 (Eastbound)				Hwy 240 (Westbound)				Total	Hourly Totals
	Left	Thru	Right	U	Left	Thru	Right	U	Left	Thru	Right	U	Left	Thru	Right	U		
11:00 AM	0	0	0	0	13	0	2	0	3	29	0	0	0	35	16	0	98	
11:05 AM	0	0	0	0	17	0	5	0	6	25	0	0	0	30	8	0	91	
11:10 AM	0	0	0	0	19	0	3	0	7	26	0	0	0	21	9	0	85	
11:15 AM	0	0	0	0	25	0	5	0	4	27	0	0	0	13	9	0	83	
11:20 AM	0	0	0	0	20	0	4	0	2	33	0	0	0	23	7	0	89	
11:25 AM	0	0	0	0	16	0	4	0	2	34	0	0	0	23	16	0	95	
11:30 AM	0	0	0	0	7	0	4	0	2	36	0	0	0	28	5	0	82	
11:35 AM	0	0	0	0	6	0	7	0	7	42	0	0	0	31	9	0	102	
11:40 AM	0	0	0	0	9	0	4	0	6	52	0	0	0	31	5	0	107	
11:45 AM	0	0	0	0	4	0	6	0	7	36	0	0	0	37	6	0	96	
11:50 AM	0	0	0	0	7	0	1	0	4	30	0	0	0	29	12	0	83	
11:55 AM	0	0	0	0	13	0	4	0	3	29	0	0	0	27	8	0	84	1095
12:00 PM	0	0	0	0	12	0	2	0	3	25	0	0	0	23	7	0	72	1069
12:05 PM	0	0	0	0	11	0	3	0	4	33	0	0	0	30	9	0	90	1068
12:10 PM	0	0	0	0	8	0	0	0	2	27	0	0	0	28	14	0	79	1062
12:15 PM	0	0	0	0	7	0	5	0	0	21	0	0	0	27	13	0	73	1052
12:20 PM	0	0	0	0	7	0	8	0	7	32	0	0	0	32	12	0	98	1061
12:25 PM	0	0	0	0	14	0	8	0	6	39	0	0	0	38	9	0	114	1080
12:30 PM	0	0	0	0	21	0	8	0	1	39	0	0	0	25	6	0	100	1098
12:35 PM	0	0	0	0	15	0	5	0	4	19	0	0	0	33	6	0	82	1078
12:40 PM	0	0	0	0	13	0	8	0	3	26	0	0	0	39	5	0	94	1065
12:45 PM	0	0	0	0	6	0	1	0	3	39	0	0	0	27	12	0	88	1057
12:50 PM	0	0	0	0	10	0	6	0	3	34	0	0	0	31	7	0	91	1065
12:55 PM	0	0	0	0	8	0	1	0	5	26	0	0	0	30	6	0	76	1057
Peak 15-Min Flowrates	Northbound				Southbound				Eastbound				Westbound				Total	
All Vehicles	0	0	0	0	168	0	96	0	56	440	0	0	0	380	108	0	1248	
Heavy Trucks	0	0	0	0	0	0	0	0	0	24	0	0	0	8	0	0	32	
Buses																		
Pedestrians		0				4				0				0			4	
Bicycles		0				0	0			0	0			0	0		0	
Scoters																		

Comments:

LOCATION: N Main St -- E Illinois St
CITY/STATE: Newberg, OR

QC JOB #: 16302722
DATE: Sat, Sep 16 2023

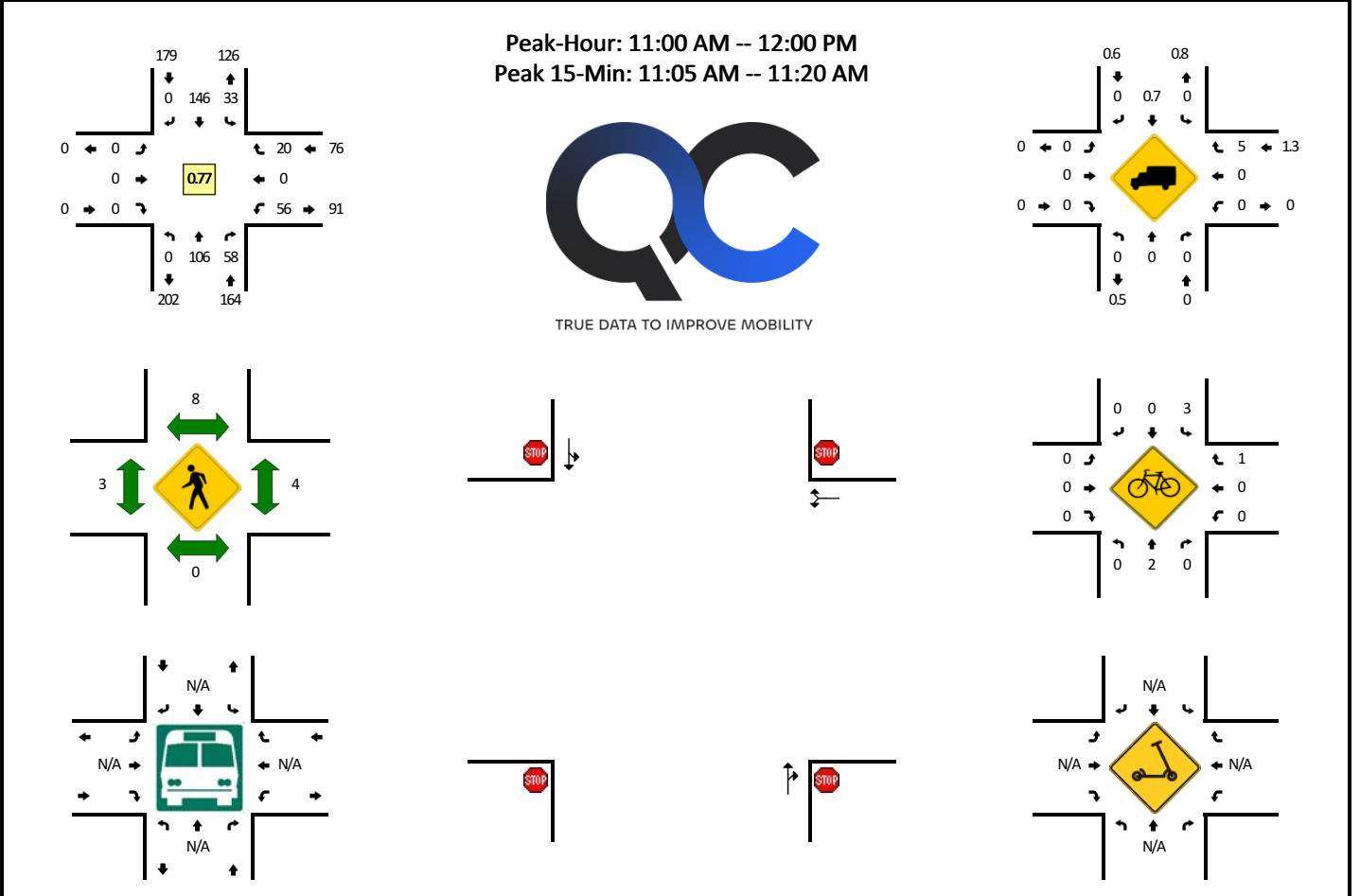

5-Min Count Period Beginning At	N Main St (Northbound)				N Main St (Southbound)				E Illinois St (Eastbound)				E Illinois St (Westbound)				Total	Hourly Totals
	Left	Thru	Right	U	Left	Thru	Right	U	Left	Thru	Right	U	Left	Thru	Right	U		
11:00 AM	0	15	4	0	5	12	0	0	0	0	0	0	4	0	1	0	41	
11:05 AM	0	9	5	0	5	15	0	0	0	0	0	0	9	0	0	0	43	
11:10 AM	0	9	7	0	5	19	0	0	0	0	0	0	1	0	3	0	44	
11:15 AM	0	10	2	0	3	26	0	0	0	0	0	0	4	0	4	0	49	
11:20 AM	0	7	3	0	3	20	0	0	0	0	0	0	4	0	1	0	38	
11:25 AM	0	13	3	0	2	12	0	0	0	0	0	0	7	0	0	0	37	
11:30 AM	0	6	2	0	0	6	0	0	0	0	0	0	4	0	1	0	19	
11:35 AM	0	8	7	0	0	6	0	0	0	0	0	0	8	0	2	0	31	
11:40 AM	0	5	8	0	2	7	0	0	0	0	0	0	3	0	0	0	25	
11:45 AM	0	8	6	0	3	5	0	0	0	0	0	0	5	0	0	0	27	
11:50 AM	0	8	8	0	2	6	0	0	0	0	0	0	3	0	7	0	34	
11:55 AM	0	8	3	0	3	12	0	0	0	0	0	0	4	0	1	0	31	419
12:00 PM	0	7	4	0	2	13	0	0	0	0	0	0	1	0	1	0	28	406
12:05 PM	0	7	6	0	4	10	0	0	0	0	0	0	5	0	0	0	32	395
12:10 PM	0	10	6	0	0	7	0	0	0	0	0	0	0	0	0	0	23	374
12:15 PM	0	9	3	0	0	6	0	0	0	0	0	0	5	0	2	0	25	350
12:20 PM	0	10	7	0	1	13	0	0	0	0	0	0	5	0	3	0	39	351
12:25 PM	0	13	5	0	7	10	0	0	0	0	0	0	11	0	2	0	48	362
12:30 PM	0	4	3	0	10	20	0	0	0	0	0	0	10	0	0	0	47	390
12:35 PM	0	5	5	0	5	15	0	0	0	0	0	0	4	0	1	0	35	394
12:40 PM	0	3	5	0	1	10	0	0	0	0	0	0	10	0	0	0	29	398
12:45 PM	0	6	9	0	3	4	0	0	0	0	0	0	3	0	1	0	26	397
12:50 PM	0	5	5	0	0	7	0	0	0	0	0	0	9	0	0	0	26	389
12:55 PM	0	7	3	0	0	6	0	0	0	0	0	0	3	0	2	0	21	379
Peak 15-Min Flowrates	Northbound				Southbound				Eastbound				Westbound				Total	
	Left	Thru	Right	U	Left	Thru	Right	U	Left	Thru	Right	U	Left	Thru	Right	U		
All Vehicles	0	112	56	0	52	240	0	0	0	0	0	0	56	0	28	0	544	
Heavy Trucks	0	0	0		0	4	0		0	0	0		0	0	0		4	
Buses																		
Pedestrians	0					16				12				12			40	
Bicycles	0	4	0		4	0	0		0	0	0		0	0	0		8	
Scoters																		

Comments: No stop sign for the NB approach.

Type of report: Tube Count - Volume Data

LOCATION: HWY 240 btwn Grant St and Main St										QC JOB #: 16302726
SPECIFIC LOCATION:										DIRECTION: EB, WB
CITY/STATE: Newberg, OR										DATE: Sep 12 2023 - Sep 18 2023
Start Time	Mon	Tue	Wed	Thu	Fri	Average Weekday	Sat	Sun	Average Week	Average Week Profile
	12 Sep 23	13 Sep 23	14 Sep 23	15 Sep 23	15 Sep 23	Hourly Traffic	16 Sep 23	17 Sep 23	Hourly Traffic	
12:00 AM		18	24	23	24	22	55	68	35	
01:00 AM		14	19	16	24	18	40	28	24	
02:00 AM		19	28	22	17	22	20	23	22	
03:00 AM		33	35	38	32	35	34	19	32	
04:00 AM		106	100	102	77	96	36	33	76	
05:00 AM		281	293	313	254	285	152	112	234	
06:00 AM		579	585	550	490	551	254	175	439	
07:00 AM		649	632	665	661	652	306	212	521	
08:00 AM		619	696	684	675	669	438	323	573	
09:00 AM		599	666	579	565	602	534	505	575	
10:00 AM		542	557	581	601	570	616	558	576	
11:00 AM		572	607	617	620	604	719	671	634	
12:00 PM		562	536	688	642	607	763	706	650	
01:00 PM		615	579	638	688	630	710	754	664	
02:00 PM		603	685	735	751	694	760	639	696	
03:00 PM		774	896	860	918	862	796	613	810	
04:00 PM		887	868	912	873	885	722	582	807	
05:00 PM		865	884	903	809	865	751	598	802	
06:00 PM		584	618	620	690	628	583	454	592	
07:00 PM		378	412	454	464	427	456	373	423	
08:00 PM		330	308	338	344	330	413	309	340	
09:00 PM		192	181	193	252	205	314	174	218	
10:00 PM		107	105	127	176	129	198	76	132	
11:00 PM		34	42	61	98	59	134	51	70	
Day Total		9962	10356	10719	10745	10447	9804	8056	9945	
% Weekday Average		95.4%	99.1%	102.6%	102.9%					
% Week Average		100.2%	104.1%	107.8%	108%	105%	98.6%	81%		
AM Peak Volume		7:00 AM 649	8:00 AM 696	8:00 AM 684	8:00 AM 675	8:00 AM 669	11:00 AM 719	11:00 AM 671	11:00 AM 634	
PM Peak Volume		4:00 PM 887	3:00 PM 896	4:00 PM 912	3:00 PM 918	4:00 PM 885	3:00 PM 796	1:00 PM 754	3:00 PM 810	

Comments:

Report generated on 9/22/2023 2:43 PM

SOURCE: Quality Counts, LLC (<http://www.qualitycounts.net>)

LOCATION: HWY 240 btwn Grant St and Main St							QC JOB #: 16302726			
SPECIFIC LOCATION:							DIRECTION: EB, WB			
CITY/STATE: Newberg, OR							DATE: Sep 12 2023 - Sep 18 2023			
Start Time	Mon 18 Sep 23	Tue	Wed	Thu	Fri	Average Weekday Hourly Traffic	Sat	Sun	Average Week Hourly Traffic	Average Week Profile
12:00 AM	25					25			25	
01:00 AM	22					22			22	
02:00 AM	18					18			18	
03:00 AM	46					46			46	
04:00 AM	117					117			117	
05:00 AM	290					290			290	
06:00 AM	591					591			591	
07:00 AM	666					666			666	
08:00 AM	605					605			605	
09:00 AM	569					569			569	
10:00 AM	528					528			528	
11:00 AM	552					552			552	
12:00 PM	622					622			622	
01:00 PM	620					620			620	
02:00 PM	619					619			619	
03:00 PM	812					812			812	
04:00 PM	907					907			907	
05:00 PM	832					832			832	
06:00 PM	558					558			558	
07:00 PM	373					373			373	
08:00 PM	292					292			292	
09:00 PM	194					194			194	
10:00 PM	101					101			101	
11:00 PM	39					39			39	
Day Total	9998					9998			9998	
% Weekday Average	100%									
% Week Average	100%					100%				
AM Peak Volume	7:00 AM 666					7:00 AM 666			7:00 AM 666	
PM Peak Volume	4:00 PM 907					4:00 PM 907			4:00 PM 907	

Comments:

Type of report: Tube Count - Volume Data

LOCATION: E Illinois St btwn Main St and Washington St										QC JOB #: 16302724
SPECIFIC LOCATION:										DIRECTION: EB, WB
CITY/STATE: Newberg, OR										DATE: Sep 12 2023 - Sep 18 2023
Start Time	Mon 12 Sep 23	Tue 13 Sep 23	Wed 14 Sep 23	Thu 15 Sep 23	Fri 15 Sep 23	Average Weekday Hourly Traffic	Sat 16 Sep 23	Sun 17 Sep 23	Average Week Hourly Traffic	Average Week Profile
12:00 AM		2	10	6	8	7	13	16	9	
01:00 AM		7	4	4	3	5	4	8	5	
02:00 AM		9	5	4	6	6	9	4	6	
03:00 AM		0	1	4	3	2	3	5	3	
04:00 AM		48	44	48	11	38	11	15	30	
05:00 AM		45	54	52	29	45	10	10	33	
06:00 AM		112	88	107	106	103	17	24	76	
07:00 AM		189	138	185	184	174	48	48	132	
08:00 AM		168	192	182	184	182	114	57	150	
09:00 AM		130	190	110	131	140	132	124	136	
10:00 AM		109	112	119	107	112	181	138	128	
11:00 AM		132	144	130	150	139	168	150	146	
12:00 PM		127	133	156	124	135	170	173	147	
01:00 PM		136	121	146	148	138	143	173	145	
02:00 PM		166	170	180	188	176	149	145	166	
03:00 PM		229	246	205	242	231	141	128	199	
04:00 PM		209	211	214	202	209	139	133	185	
05:00 PM		226	205	222	205	215	162	148	195	
06:00 PM		171	167	190	155	171	130	116	155	
07:00 PM		118	121	123	104	117	81	100	108	
08:00 PM		84	79	103	76	86	68	62	79	
09:00 PM		36	51	57	52	49	45	37	46	
10:00 PM		30	28	26	28	28	30	15	26	
11:00 PM		9	18	19	20	17	29	12	18	
Day Total		2492	2532	2592	2466	2525	1997	1841	2323	
% Weekday Average		98.7%	100.3%	102.7%	97.7%					
% Week Average		107.3%	109%	111.6%	106.2%	108.7%	86%	79.3%		
AM Peak Volume		7:00 AM 189	8:00 AM 192	7:00 AM 185	7:00 AM 184	8:00 AM 182	10:00 AM 181	11:00 AM 150	8:00 AM 150	
PM Peak Volume		3:00 PM 229	3:00 PM 246	5:00 PM 222	3:00 PM 242	3:00 PM 231	12:00 PM 170	12:00 PM 173	3:00 PM 199	

Comments:

Report generated on 9/22/2023 2:43 PM

SOURCE: Quality Counts, LLC (<http://www.qualitycounts.net>)

LOCATION: E Illinois St btwn Main St and Washington St **QC JOB #:** 16302724
SPECIFIC LOCATION: **DIRECTION:** EB, WB
CITY/STATE: Newberg, OR **DATE:** Sep 12 2023 - Sep 18 2023

Start Time	Mon 18 Sep 23	Tue	Wed	Thu	Fri	Average Weekday Hourly Traffic	Sat	Sun	Average Week Hourly Traffic	Average Week Profile
12:00 AM	9					9			9	
01:00 AM	4					4			4	
02:00 AM	3					3			3	
03:00 AM	2					2			2	
04:00 AM	52					52			52	
05:00 AM	51					51			51	
06:00 AM	102					102			102	
07:00 AM	190					190			190	
08:00 AM	168					168			168	
09:00 AM	123					123			123	
10:00 AM	115					115			115	
11:00 AM	138					138			138	
12:00 PM	143					143			143	
01:00 PM	150					150			150	
02:00 PM	159					159			159	
03:00 PM	220					220			220	
04:00 PM	219					219			219	
05:00 PM	189					189			189	
06:00 PM	142					142			142	
07:00 PM	115					115			115	
08:00 PM	67					67			67	
09:00 PM	52					52			52	
10:00 PM	19					19			19	
11:00 PM	5					5			5	
Day Total	2437					2437			2437	
% Weekday Average	100%									
% Week Average	100%					100%				
AM Peak Volume	7:00 AM 190					7:00 AM 190			7:00 AM 190	
PM Peak Volume	3:00 PM 220					3:00 PM 220			3:00 PM 220	

Comments:

Type of report: Tube Count - Volume Data

LOCATION: HWY 240 btwn Illinois St and North St										QC JOB #: 16302725
SPECIFIC LOCATION:										DIRECTION: NB, SB
CITY/STATE: Newberg, OR										DATE: Sep 12 2023 - Sep 18 2023
Start Time	Mon	Tue	Wed	Thu	Fri	Average Weekday	Sat	Sun	Average Week	Average Week Profile
		12 Sep 23	13 Sep 23	14 Sep 23	15 Sep 23	Hourly Traffic	16 Sep 23	17 Sep 23	Hourly Traffic	
12:00 AM		17	27	22	29	24	54	84	39	
01:00 AM		20	18	17	26	20	43	31	26	
02:00 AM		21	34	26	21	26	28	26	26	
03:00 AM		36	36	41	35	37	37	25	35	
04:00 AM		121	125	120	79	111	36	30	85	
05:00 AM		309	311	341	266	307	156	115	250	
06:00 AM		629	623	599	565	604	288	204	485	
07:00 AM		740	718	778	700	734	366	301	601	
08:00 AM		677	759	721	744	725	561	381	641	
09:00 AM		692	676	607	680	664	718	596	662	
10:00 AM		599	631	663	676	642	799	643	669	
11:00 AM		637	666	719	735	689	902	808	745	
12:00 PM		625	662	770	755	703	903	795	752	
01:00 PM		645	684	751	738	705	853	885	759	
02:00 PM		734	773	783	849	785	867	776	797	
03:00 PM		856	1035	935	955	945	833	732	891	
04:00 PM		917	932	937	986	943	783	721	879	
05:00 PM		946	1023	994	990	988	854	724	922	
06:00 PM		718	787	712	766	746	645	550	696	
07:00 PM		511	479	544	581	529	534	468	520	
08:00 PM		365	371	392	412	385	475	360	396	
09:00 PM		222	213	219	288	236	381	205	255	
10:00 PM		112	105	137	197	138	224	93	145	
11:00 PM		30	51	63	115	65	153	54	78	
Day Total		11179	11739	11891	12188	11751	11493	9607	11354	
% Weekday Average		95.1%	99.9%	101.2%	103.7%					
% Week Average		98.5%	103.4%	104.7%	107.3%	103.5%	101.2%	84.6%		
AM Peak Volume		7:00 AM 740	8:00 AM 759	7:00 AM 778	8:00 AM 744	7:00 AM 734	11:00 AM 902	11:00 AM 808	11:00 AM 745	
PM Peak Volume		5:00 PM 946	3:00 PM 1035	5:00 PM 994	5:00 PM 990	5:00 PM 988	12:00 PM 903	1:00 PM 885	5:00 PM 922	

Comments:

Report generated on 9/22/2023 2:43 PM

SOURCE: Quality Counts, LLC (<http://www.qualitycounts.net>)

LOCATION: HWY 240 btwn Illinois St and North St **QC JOB #:** 16302725
SPECIFIC LOCATION: **DIRECTION:** NB, SB
CITY/STATE: Newberg, OR **DATE:** Sep 12 2023 - Sep 18 2023

Start Time	Mon 18 Sep 23	Tue	Wed	Thu	Fri	Average Weekday Hourly Traffic	Sat	Sun	Average Week Hourly Traffic	Average Week Profile
12:00 AM	29					29			29	
01:00 AM	27					27			27	
02:00 AM	17					17			17	
03:00 AM	46					46			46	
04:00 AM	131					131			131	
05:00 AM	321					321			321	
06:00 AM	643					643			643	
07:00 AM	725					725			725	
08:00 AM	690					690			690	
09:00 AM	654					654			654	
10:00 AM	611					611			611	
11:00 AM	685					685			685	
12:00 PM	665					665			665	
01:00 PM	648					648			648	
02:00 PM	729					729			729	
03:00 PM	951					951			951	
04:00 PM	963					963			963	
05:00 PM	930					930			930	
06:00 PM	675					675			675	
07:00 PM	428					428			428	
08:00 PM	354					354			354	
09:00 PM	212					212			212	
10:00 PM	119					119			119	
11:00 PM	46					46			46	
Day Total	11299					11299			11299	
% Weekday Average	100%									
% Week Average	100%					100%				
AM Peak Volume	7:00 AM 725					7:00 AM 725			7:00 AM 725	
PM Peak Volume	4:00 PM 963					4:00 PM 963			4:00 PM 963	

Comments:

Type of report: Tube Count - Volume Data

LOCATION: N Main St btwn Clifford Ct and Illinois St										QC JOB #: 16302723	
SPECIFIC LOCATION:										DIRECTION: NB, SB	
CITY/STATE: Newberg, OR										DATE: Sep 12 2023 - Sep 18 2023	
Start Time	Mon 12 Sep 23	Tue 13 Sep 23	Wed 14 Sep 23	Thu 15 Sep 23	Fri 15 Sep 23	Average Weekday Hourly Traffic	Sat 16 Sep 23	Sun 17 Sep 23	Average Week Hourly Traffic	Average Week Profile	
12:00 AM		1	5	0	9	4	6	24	8		
01:00 AM		3	1	0	3	2	5	5	3		
02:00 AM		3	4	2	3	3	6	6	4		
03:00 AM		3	4	2	1	3	4	5	3		
04:00 AM		5	10	13	5	8	5	4	7		
05:00 AM		25	25	28	15	23	9	10	19		
06:00 AM		68	52	65	74	65	35	34	55		
07:00 AM		154	121	146	132	138	60	111	121		
08:00 AM		138	164	120	137	140	217	93	145		
09:00 AM		134	127	90	109	115	237	149	141		
10:00 AM		122	109	116	135	121	286	164	155		
11:00 AM		123	127	124	146	130	289	221	172		
12:00 PM		132	116	129	136	128	207	219	157		
01:00 PM		132	134	139	151	139	206	253	169		
02:00 PM		144	158	143	166	153	185	194	165		
03:00 PM		192	211	171	190	191	146	150	177		
04:00 PM		219	239	195	189	211	169	181	199		
05:00 PM		261	278	249	252	260	154	220	236		
06:00 PM		187	245	183	141	189	157	127	173		
07:00 PM		145	146	115	136	136	94	116	125		
08:00 PM		81	78	96	90	86	81	71	83		
09:00 PM		55	50	51	61	54	73	36	54		
10:00 PM		20	13	23	28	21	35	21	23		
11:00 PM		7	15	8	22	13	27	12	15		
Day Total		2354	2432	2208	2331	2333	2693	2426	2409		
% Weekday Average		100.9%	104.2%	94.6%	99.9%						
% Week Average		97.7%	101%	91.7%	96.8%	96.8%	111.8%	100.7%			
AM Peak Volume		7:00 AM 154	8:00 AM 164	7:00 AM 146	11:00 AM 146	8:00 AM 140	11:00 AM 289	11:00 AM 221	11:00 AM 172		
PM Peak Volume		5:00 PM 261	5:00 PM 278	5:00 PM 249	5:00 PM 252	5:00 PM 260	12:00 PM 207	1:00 PM 253	5:00 PM 236		

Comments:

Report generated on 9/22/2023 2:43 PM

SOURCE: Quality Counts, LLC (<http://www.qualitycounts.net>)

LOCATION: N Main St btwn Clifford Ct and Illinois St **QC JOB #:** 16302723
SPECIFIC LOCATION: **DIRECTION:** NB, SB
CITY/STATE: Newberg, OR **DATE:** Sep 12 2023 - Sep 18 2023

Start Time	Mon 18 Sep 23	Tue	Wed	Thu	Fri	Average Weekday Hourly Traffic	Sat	Sun	Average Week Hourly Traffic	Average Week Profile
12:00 AM	3					3			3	
01:00 AM	5					5			5	
02:00 AM	1					1			1	
03:00 AM	1					1			1	
04:00 AM	10					10			10	
05:00 AM	25					25			25	
06:00 AM	67					67			67	
07:00 AM	156					156			156	
08:00 AM	118					118			118	
09:00 AM	121					121			121	
10:00 AM	114					114			114	
11:00 AM	110					110			110	
12:00 PM	105					105			105	
01:00 PM	136					136			136	
02:00 PM	129					129			129	
03:00 PM	160					160			160	
04:00 PM	205					205			205	
05:00 PM	197					197			197	
06:00 PM	189					189			189	
07:00 PM	96					96			96	
08:00 PM	61					61			61	
09:00 PM	58					58			58	
10:00 PM	22					22			22	
11:00 PM	7					7			7	
Day Total	2096					2096			2096	
% Weekday Average	100%									
% Week Average	100%					100%				
AM Peak Volume	7:00 AM 156					7:00 AM 156			7:00 AM 156	
PM Peak Volume	4:00 PM 205					4:00 PM 205			4:00 PM 205	

Comments:

Type of report: Tube Count - Vehicle Classification Data

LOCATION: N Main St btwn Clifford Ct and Illinois St
SPECIFIC LOCATION:
CITY/STATE: Newberg, OR

QC JOB #: 16302723
DIRECTION: SB
DATE: Sep 12 2023

Start Time	Bikes	Cars & Trailers	2 Axle Long	Buses	2 Axle 6 Tire	3 Axle Single	4 Axle Single	<5 Axl Double	5 Axle Double	>6 Axl Double	<6 Axl Multi	6 Axle Multi	>6 Axl Multi	Not Classed	Total
12:00 AM	0	0	0	0	0	0	0	0	0	0	0	0	0	0	0
01:00 AM	0	1	0	0	0	0	0	0	0	0	0	0	0	0	1
02:00 AM	0	0	1	0	0	0	0	0	0	0	0	0	0	0	1
03:00 AM	0	1	2	0	0	0	0	0	0	0	0	0	0	0	3
04:00 AM	0	2	2	0	1	0	0	0	0	0	0	0	0	0	5
05:00 AM	1	13	5	0	1	0	0	0	0	0	0	0	0	0	20
06:00 AM	0	24	15	0	6	0	0	0	0	0	0	0	0	0	45
07:00 AM	1	51	17	2	13	0	0	1	0	0	0	0	0	0	85
08:00 AM	0	44	18	0	11	2	0	1	1	0	0	0	0	2	79
09:00 AM	0	41	16	1	10	0	0	4	0	0	0	0	0	2	74
10:00 AM	0	40	13	0	9	0	0	0	0	0	0	0	0	1	63
11:00 AM	0	30	12	1	7	0	0	4	0	0	0	0	0	0	54
12:00 PM	1	31	15	1	9	0	0	0	0	0	0	0	0	1	58
01:00 PM	2	29	14	0	9	0	0	0	0	0	0	0	0	1	55
02:00 PM	0	30	21	1	10	0	0	2	0	0	0	0	0	2	66
03:00 PM	0	52	22	1	12	0	0	2	0	0	0	0	0	2	91
04:00 PM	0	45	18	0	13	0	0	1	0	0	0	0	0	2	79
05:00 PM	1	52	25	1	7	0	0	1	0	0	0	0	0	5	92
06:00 PM	1	51	26	0	6	0	0	0	0	0	0	0	0	0	84
07:00 PM	0	33	13	1	8	0	0	0	0	0	0	0	0	0	55
08:00 PM	0	20	10	0	4	0	0	0	0	0	0	0	0	1	35
09:00 PM	0	20	3	0	3	0	0	0	0	0	0	0	0	1	27
10:00 PM	0	2	4	0	1	0	0	0	0	0	0	0	0	0	7
11:00 PM	0	3	0	0	0	0	0	0	0	0	0	0	0	0	3
Day Total	7	615	272	9	140	2	0	16	1	0	0	0	0	20	1082
Percent	0.6%	56.8%	25.1%	0.8%	12.9%	0.2%	0%	1.5%	0.1%	0%	0%	0%	0%	1.8%	
ADT 1082															
AM Peak Volume	5:00 AM 1	7:00 AM 51	8:00 AM 18	7:00 AM 2	7:00 AM 13	8:00 AM 2	12:00 AM 0	9:00 AM 4	8:00 AM 1	12:00 AM 0	12:00 AM 0	12:00 AM 0	12:00 AM 0	8:00 AM 2	7:00 AM 85
PM Peak Volume	1:00 PM 2	3:00 PM 52	6:00 PM 26	12:00 PM 1	4:00 PM 13	12:00 PM 0	12:00 PM 0	2:00 PM 2	12:00 PM 0	12:00 PM 0	12:00 PM 0	12:00 PM 0	12:00 PM 0	5:00 PM 5	5:00 PM 92

Comments:

Type of report: Tube Count - Vehicle Classification Data

LOCATION: N Main St btwn Clifford Ct and Illinois St

QC JOB #: 16302723

SPECIFIC LOCATION:

DIRECTION: SB

CITY/STATE: Newberg, OR

DATE: Sep 13 2023

Start Time	Bikes	Cars & Trailers	2 Axle Long	Buses	2 Axle 6 Tire	3 Axle Single	4 Axle Single	<5 Axl Double	5 Axle Double	>6 Axl Double	<6 Axl Multi	6 Axle Multi	>6 Axl Multi	Not Classed	Total
12:00 AM	0	0	0	0	0	0	0	0	0	0	0	0	0	0	0
01:00 AM	0	1	0	0	0	0	0	0	0	0	0	0	0	0	1
02:00 AM	0	0	0	0	1	0	0	0	0	0	0	0	0	0	1
03:00 AM	0	1	1	0	0	0	0	0	0	0	0	0	0	0	2
04:00 AM	0	3	4	0	2	0	0	0	0	0	0	0	0	0	9
05:00 AM	0	14	3	0	2	0	0	0	0	0	0	0	0	0	19
06:00 AM	0	20	7	0	3	0	0	0	0	0	0	0	0	1	31
07:00 AM	1	42	12	0	18	0	0	0	0	0	0	0	0	0	73
08:00 AM	0	49	22	2	9	0	0	3	0	0	0	0	0	3	88
09:00 AM	0	36	19	0	7	0	0	0	0	0	0	0	0	1	63
10:00 AM	0	38	10	0	7	0	0	0	0	0	0	0	0	0	55
11:00 AM	0	32	11	0	8	0	0	0	0	0	0	0	0	1	52
12:00 PM	1	33	11	0	6	0	0	1	0	0	0	0	0	0	52
01:00 PM	1	36	13	1	6	0	0	2	0	0	0	0	0	0	59
02:00 PM	1	45	17	1	5	0	1	0	0	0	0	0	0	1	71
03:00 PM	1	41	27	2	14	0	0	1	0	0	0	0	0	4	90
04:00 PM	1	38	17	0	8	0	0	1	0	0	0	0	0	1	66
05:00 PM	3	52	18	0	7	0	0	1	0	0	0	0	0	10	91
06:00 PM	2	92	28	0	10	0	0	0	0	0	0	0	0	3	135
07:00 PM	3	30	10	0	8	0	0	0	0	0	0	0	0	3	54
08:00 PM	3	15	7	0	2	0	0	0	0	0	0	0	0	0	27
09:00 PM	0	12	3	0	1	0	0	0	0	0	0	0	0	0	16
10:00 PM	0	1	0	0	2	0	0	0	0	0	0	0	0	0	3
11:00 PM	0	5	1	0	2	0	0	0	0	0	0	0	0	0	8
Day Total	17	636	241	6	128	0	1	9	0	0	0	0	0	28	1066
Percent	1.6%	59.7%	22.6%	0.6%	12%	0%	0.1%	0.8%	0%	0%	0%	0%	0%	2.6%	
ADT 1066															
AM Peak Volume	7:00 AM 1	8:00 AM 49	8:00 AM 22	8:00 AM 2	7:00 AM 18	12:00 AM 0	12:00 AM 0	8:00 AM 3	12:00 AM 0	12:00 AM 0	12:00 AM 0	12:00 AM 0	12:00 AM 0	8:00 AM 3	8:00 AM 88
PM Peak Volume	5:00 PM 3	6:00 PM 92	6:00 PM 28	3:00 PM 2	3:00 PM 14	12:00 PM 0	2:00 PM 1	1:00 PM 2	12:00 PM 0	12:00 PM 0	12:00 PM 0	12:00 PM 0	12:00 PM 0	5:00 PM 10	6:00 PM 135

Comments:

Report generated on 9/22/2023 2:43 PM

SOURCE: Quality Counts, LLC (<http://www.qualitycounts.net>)

Type of report: Tube Count - Vehicle Classification Data

LOCATION: N Main St btwn Clifford Ct and Illinois St

QC JOB #: 16302723

SPECIFIC LOCATION:

DIRECTION: SB

CITY/STATE: Newberg, OR

DATE: Sep 14 2023

Start Time	Bikes	Cars & Trailers	2 Axle Long	Buses	2 Axle 6 Tire	3 Axle Single	4 Axle Single	<5 Axl Double	5 Axle Double	>6 Axl Double	<6 Axl Multi	6 Axle Multi	>6 Axl Multi	Not Classed	Total
12:00 AM	0	0	0	0	0	0	0	0	0	0	0	0	0	0	0
01:00 AM	0	0	0	0	0	0	0	0	0	0	0	0	0	0	0
02:00 AM	0	0	1	0	1	0	0	0	0	0	0	0	0	0	2
03:00 AM	0	1	1	0	0	0	0	0	0	0	0	0	0	0	2
04:00 AM	0	1	5	0	3	0	0	0	0	0	0	0	0	0	9
05:00 AM	0	10	4	0	5	0	0	0	0	0	0	0	0	0	19
06:00 AM	0	22	10	0	8	0	0	1	0	0	0	0	0	0	41
07:00 AM	1	61	9	2	12	0	0	0	0	0	0	0	0	0	85
08:00 AM	0	36	11	1	7	0	0	3	0	0	0	0	0	2	60
09:00 AM	0	29	13	0	5	0	0	0	0	0	0	0	0	1	48
10:00 AM	0	43	16	0	8	0	0	1	0	0	0	0	0	0	68
11:00 AM	0	28	13	0	3	0	0	1	0	0	0	0	0	3	48
12:00 PM	0	27	12	1	5	0	0	0	0	0	0	0	0	2	47
01:00 PM	1	33	12	0	6	0	0	1	0	0	0	0	0	0	53
02:00 PM	0	23	15	1	10	0	0	1	0	0	0	0	0	1	51
03:00 PM	1	43	21	2	8	0	0	0	0	0	0	0	0	1	76
04:00 PM	0	43	15	0	3	0	0	0	0	0	0	0	0	4	65
05:00 PM	0	54	19	0	11	0	0	0	1	0	0	0	0	4	89
06:00 PM	0	57	16	0	10	0	0	0	0	0	0	0	0	0	83
07:00 PM	2	27	12	0	3	0	0	1	0	0	0	0	0	4	49
08:00 PM	0	30	2	0	3	0	0	0	0	0	0	0	0	0	35
09:00 PM	0	15	4	0	1	0	0	0	0	0	0	0	0	6	26
10:00 PM	0	4	0	0	1	0	0	0	0	0	0	0	0	0	5
11:00 PM	0	0	2	0	1	0	0	1	0	0	0	0	0	0	4
Day Total	5	587	213	7	114	0	0	10	1	0	0	0	0	28	965
Percent	0.5%	60.8%	22.1%	0.7%	11.8%	0%	0%	1%	0.1%	0%	0%	0%	0%	2.9%	
ADT 965															
AM Peak Volume	7:00 AM 1	7:00 AM 61	10:00 AM 16	7:00 AM 2	7:00 AM 12	12:00 AM 0	12:00 AM 0	8:00 AM 3	12:00 AM 0	12:00 AM 0	12:00 AM 0	12:00 AM 0	12:00 AM 0	11:00 AM 3	7:00 AM 85
PM Peak Volume	7:00 PM 2	6:00 PM 57	3:00 PM 21	3:00 PM 2	5:00 PM 11	12:00 PM 0	12:00 PM 0	1:00 PM 1	5:00 PM 1	12:00 PM 0	12:00 PM 0	12:00 PM 0	12:00 PM 0	9:00 PM 6	5:00 PM 89

Comments:

LOCATION: N Main St btwn Clifford Ct and Illinois St

QC JOB #: 16302723

SPECIFIC LOCATION:

DIRECTION: SB

CITY/STATE: Newberg, OR

DATE: Sep 15 2023

Start Time	Bikes	Cars & Trailers	2 Axle Long	Buses	2 Axle 6 Tire	3 Axle Single	4 Axle Single	<5 Axl Double	5 Axle Double	>6 Axl Double	<6 Axl Multi	6 Axle Multi	>6 Axl Multi	Not Classed	Total
12:00 AM	0	2	2	0	0	0	0	0	0	0	0	0	0	0	4
01:00 AM	0	1	0	0	1	0	0	0	0	0	0	0	0	0	2
02:00 AM	0	2	1	0	0	0	0	0	0	0	0	0	0	0	3
03:00 AM	0	0	0	0	0	0	0	0	0	0	0	0	0	0	0
04:00 AM	0	0	2	0	2	0	0	0	0	0	0	0	0	0	4
05:00 AM	0	8	1	0	2	0	0	0	0	0	0	0	0	0	11
06:00 AM	0	28	11	0	9	0	0	0	0	0	0	0	0	0	48
07:00 AM	0	48	19	2	9	0	0	1	0	0	0	0	0	0	79
08:00 AM	0	48	12	1	8	0	0	2	0	0	0	0	0	1	72
09:00 AM	0	40	7	0	11	0	0	0	0	0	0	0	0	0	58
10:00 AM	0	44	13	1	14	0	0	1	0	0	0	0	0	3	76
11:00 AM	1	46	16	1	14	0	0	2	0	0	0	0	0	2	82
12:00 PM	0	37	17	0	8	0	0	2	0	0	0	0	0	2	66
01:00 PM	0	36	21	1	7	0	0	1	0	0	0	0	0	0	66
02:00 PM	0	29	21	1	9	0	0	2	0	0	0	0	0	2	64
03:00 PM	0	37	20	2	9	0	0	3	0	0	0	0	0	1	72
04:00 PM	2	37	17	0	9	0	0	2	0	0	0	0	0	1	68
05:00 PM	0	66	24	0	8	1	0	2	0	0	0	0	0	7	108
06:00 PM	0	33	16	0	10	1	0	0	0	0	0	0	0	1	61
07:00 PM	0	28	15	0	6	0	0	0	0	0	0	0	0	0	49
08:00 PM	0	21	5	0	3	0	0	0	0	0	0	0	0	1	30
09:00 PM	0	12	8	0	4	0	0	0	0	0	0	0	0	0	24
10:00 PM	0	9	1	0	1	0	0	0	0	0	0	0	0	0	11
11:00 PM	0	4	1	0	0	0	0	0	0	0	0	0	0	0	5
Day Total	3	616	250	9	144	2	0	18	0	0	0	0	0	21	1063
Percent	0.3%	57.9%	23.5%	0.8%	13.5%	0.2%	0%	1.7%	0%	0%	0%	0%	0%	2%	
ADT 1063															
AM Peak Volume	11:00 AM 1	7:00 AM 48	7:00 AM 19	7:00 AM 2	10:00 AM 14	12:00 AM 0	12:00 AM 0	8:00 AM 2	12:00 AM 0	12:00 AM 0	12:00 AM 0	12:00 AM 0	12:00 AM 0	10:00 AM 3	11:00 AM 82
PM Peak Volume	4:00 PM 2	5:00 PM 66	5:00 PM 24	3:00 PM 2	6:00 PM 10	5:00 PM 1	12:00 PM 0	3:00 PM 3	12:00 PM 0	12:00 PM 0	12:00 PM 0	12:00 PM 0	12:00 PM 0	5:00 PM 7	5:00 PM 108

Comments:

LOCATION: N Main St btwn Clifford Ct and Illinois St
SPECIFIC LOCATION:
CITY/STATE: Newberg, OR

QC JOB #: 16302723
DIRECTION: SB
DATE: Sep 16 2023

Start Time	Bikes	Cars & Trailers	2 Axle Long	Buses	2 Axle 6 Tire	3 Axle Single	4 Axle Single	<5 Axl Double	5 Axle Double	>6 Axl Double	<6 Axl Multi	6 Axle Multi	>6 Axl Multi	Not Classed	Total
12:00 AM	0	2	1	0	0	0	0	0	0	0	0	0	0	0	3
01:00 AM	0	2	1	0	0	0	0	0	0	0	0	0	0	0	3
02:00 AM	0	2	0	0	0	0	0	0	0	0	0	0	0	0	2
03:00 AM	0	1	1	0	0	0	0	0	0	0	0	0	0	0	2
04:00 AM	0	1	0	0	1	0	0	0	0	0	0	0	0	0	2
05:00 AM	0	5	0	0	0	0	0	0	0	0	0	0	0	0	5
06:00 AM	0	12	3	0	3	0	0	0	0	0	0	0	0	0	18
07:00 AM	0	25	12	0	5	0	0	1	0	0	0	0	0	0	43
08:00 AM	0	35	26	0	7	0	0	1	0	0	0	0	0	1	70
09:00 AM	0	49	19	0	9	0	0	1	0	0	0	0	0	4	82
10:00 AM	0	85	35	0	16	1	0	1	0	0	0	0	0	3	141
11:00 AM	2	96	45	0	19	0	0	3	0	0	0	0	0	4	169
12:00 PM	3	60	37	1	9	1	0	0	0	0	0	0	0	13	124
01:00 PM	0	42	28	0	11	1	0	0	0	0	0	0	0	1	83
02:00 PM	0	47	20	0	19	0	0	0	0	0	0	0	0	3	89
03:00 PM	0	27	16	0	8	0	0	0	0	0	0	0	0	3	54
04:00 PM	2	48	13	0	12	0	0	0	0	0	0	0	0	2	77
05:00 PM	2	40	17	0	4	0	0	0	0	0	0	0	0	2	65
06:00 PM	4	51	19	0	5	0	0	0	0	0	0	0	0	1	80
07:00 PM	0	20	6	0	5	0	0	1	0	0	0	0	0	0	32
08:00 PM	0	17	4	0	4	0	0	0	0	0	0	0	0	1	26
09:00 PM	1	22	8	0	1	0	0	0	0	0	0	0	0	0	32
10:00 PM	0	9	2	0	0	0	0	0	0	0	0	0	0	0	11
11:00 PM	0	7	1	0	0	0	0	0	0	0	0	0	0	0	8
Day Total	14	705	314	1	138	3	0	8	0	0	0	0	0	38	1221
Percent	1.1%	57.7%	25.7%	0.1%	11.3%	0.2%	0%	0.7%	0%	0%	0%	0%	0%	3.1%	
ADT 1221															
AM Peak	11:00 AM	11:00 AM	11:00 AM	12:00 AM	11:00 AM	10:00 AM	12:00 AM	11:00 AM	12:00 AM	12:00 AM	12:00 AM	12:00 AM	12:00 AM	9:00 AM	11:00 AM
Volume	2	96	45	0	19	1	0	3	0	0	0	0	0	4	169
PM Peak	6:00 PM	12:00 PM	12:00 PM	12:00 PM	2:00 PM	12:00 PM	12:00 PM	7:00 PM	12:00 PM	12:00 PM	12:00 PM	12:00 PM	12:00 PM	12:00 PM	12:00 PM
Volume	4	60	37	1	19	1	0	1	0	0	0	0	0	13	124

Comments:

LOCATION: N Main St btwn Clifford Ct and Illinois St
SPECIFIC LOCATION:
CITY/STATE: Newberg, OR

QC JOB #: 16302723
DIRECTION: SB
DATE: Sep 17 2023

Start Time	Bikes	Cars & Trailers	2 Axle Long	Buses	2 Axle 6 Tire	3 Axle Single	4 Axle Single	<5 Axl Double	5 Axle Double	>6 Axl Double	<6 Axl Multi	6 Axle Multi	>6 Axl Multi	Not Classed	Total
12:00 AM	0	5	0	0	0	0	0	0	0	0	0	0	0	0	5
01:00 AM	0	1	1	0	1	0	0	0	0	0	0	0	0	0	3
02:00 AM	0	1	0	0	0	0	0	0	0	0	0	0	0	0	1
03:00 AM	0	1	0	0	0	0	0	0	0	0	0	0	0	0	1
04:00 AM	0	0	2	0	1	0	0	0	0	0	0	0	0	0	3
05:00 AM	0	5	2	0	0	0	0	0	0	0	0	0	0	0	7
06:00 AM	0	8	3	0	2	0	0	0	0	0	0	0	0	1	14
07:00 AM	1	27	11	0	6	0	0	0	0	0	0	0	0	1	46
08:00 AM	0	27	12	0	1	0	0	0	0	0	0	0	0	1	41
09:00 AM	0	58	13	0	11	0	0	0	0	0	0	0	0	1	83
10:00 AM	0	48	17	0	5	0	0	1	0	0	0	0	0	0	71
11:00 AM	0	51	33	0	16	0	0	1	0	0	0	0	0	2	103
12:00 PM	1	45	18	0	9	0	0	0	0	0	0	0	0	3	76
01:00 PM	1	85	27	0	13	0	0	0	0	0	0	0	0	2	128
02:00 PM	0	51	23	0	20	0	0	1	0	0	0	0	0	3	98
03:00 PM	1	34	14	0	7	0	0	2	0	0	0	0	0	1	59
04:00 PM	0	55	17	0	12	0	0	0	0	0	0	0	0	0	84
05:00 PM	0	67	28	0	13	0	0	1	0	0	0	0	0	5	114
06:00 PM	0	34	14	0	5	0	0	0	0	0	0	0	0	1	54
07:00 PM	0	31	10	0	3	0	0	0	0	0	0	0	0	0	44
08:00 PM	1	14	7	0	2	0	0	0	0	0	0	0	0	0	24
09:00 PM	0	10	4	0	1	0	0	0	0	0	0	0	0	0	15
10:00 PM	0	7	0	0	1	0	0	0	0	0	0	0	0	0	8
11:00 PM	0	4	1	0	0	0	0	0	0	0	0	0	0	0	5
Day Total	5	669	257	0	129	0	0	6	0	0	0	0	0	21	1087
Percent	0.5%	61.5%	23.6%	0%	11.9%	0%	0%	0.6%	0%	0%	0%	0%	0%	1.9%	
ADT 1087															
AM Peak Volume	7:00 AM 1	9:00 AM 58	11:00 AM 33	12:00 AM 0	11:00 AM 16	12:00 AM 0	12:00 AM 0	10:00 AM 1	12:00 AM 0	12:00 AM 0	12:00 AM 0	12:00 AM 0	12:00 AM 0	11:00 AM 2	11:00 AM 103
PM Peak Volume	12:00 PM 1	1:00 PM 85	5:00 PM 28	12:00 PM 0	2:00 PM 20	12:00 PM 0	12:00 PM 0	3:00 PM 2	12:00 PM 0	12:00 PM 0	12:00 PM 0	12:00 PM 0	12:00 PM 0	5:00 PM 5	1:00 PM 128

Comments:

Type of report: Tube Count - Vehicle Classification Data

LOCATION: N Main St btwn Clifford Ct and Illinois St **QC JOB #:** 16302723
SPECIFIC LOCATION: **DIRECTION:** SB
CITY/STATE: Newberg, OR **DATE:** Sep 18 2023

Start Time	Bikes	Cars & Trailers	2 Axle Long	Buses	2 Axle 6 Tire	3 Axle Single	4 Axle Single	<5 Axl Double	5 Axle Double	>6 Axl Double	<6 Axl Multi	6 Axle Multi	>6 Axl Multi	Not Classed	Total
12:00 AM	0	1	0	0	0	0	0	0	0	0	0	0	0	0	1
01:00 AM	0	0	1	0	1	0	0	0	0	0	0	0	0	0	2
02:00 AM	0	0	0	0	0	0	0	0	0	0	0	0	0	0	0
03:00 AM	0	0	1	0	0	0	0	0	0	0	0	0	0	0	1
04:00 AM	0	6	2	0	1	0	0	0	0	0	0	0	0	0	9
05:00 AM	0	13	2	0	4	0	0	0	0	0	0	0	0	0	19
06:00 AM	0	27	13	0	9	0	0	0	0	0	0	0	0	0	49
07:00 AM	1	48	19	2	11	0	0	0	0	0	0	0	0	4	85
08:00 AM	0	36	14	1	8	0	0	0	0	0	0	0	0	0	59
09:00 AM	0	37	11	0	10	0	0	2	0	0	0	0	0	0	60
10:00 AM	0	34	13	1	4	0	0	0	0	0	0	0	0	0	52
11:00 AM	1	31	10	1	5	0	0	2	0	0	0	0	0	1	51
12:00 PM	0	28	9	0	10	0	0	0	0	0	0	0	0	0	47
01:00 PM	0	31	6	0	4	0	0	1	0	0	0	0	0	0	42
02:00 PM	1	32	12	1	6	0	0	1	0	0	0	0	0	3	56
03:00 PM	1	36	13	2	10	2	0	1	1	0	0	0	0	3	69
04:00 PM	0	47	17	0	8	0	0	0	0	0	0	0	0	6	78
05:00 PM	0	36	17	0	10	0	0	0	0	0	0	0	0	1	64
06:00 PM	1	52	22	0	11	0	0	0	0	0	0	0	0	1	87
07:00 PM	0	21	10	0	6	0	0	0	0	0	0	0	0	0	37
08:00 PM	0	13	4	0	4	0	0	1	0	0	0	0	0	0	22
09:00 PM	0	20	2	0	0	0	0	0	0	0	0	0	0	0	22
10:00 PM	0	5	1	0	1	0	0	0	0	0	0	0	0	0	7
11:00 PM	0	3	0	0	1	0	0	0	0	0	0	0	0	0	4
Day Total	5	557	199	8	124	2	0	8	1	0	0	0	0	19	923
Percent	0.5%	60.3%	21.6%	0.9%	13.4%	0.2%	0%	0.9%	0.1%	0%	0%	0%	0%	2.1%	
ADT 923															
AM Peak Volume	7:00 AM 1	7:00 AM 48	7:00 AM 19	7:00 AM 2	7:00 AM 11	12:00 AM 0	12:00 AM 0	9:00 AM 2	12:00 AM 0	12:00 AM 0	12:00 AM 0	12:00 AM 0	12:00 AM 0	7:00 AM 4	7:00 AM 85
PM Peak Volume	2:00 PM 1	6:00 PM 52	6:00 PM 22	3:00 PM 2	6:00 PM 11	3:00 PM 2	12:00 PM 0	1:00 PM 1	3:00 PM 1	12:00 PM 0	12:00 PM 0	12:00 PM 0	12:00 PM 0	4:00 PM 6	6:00 PM 87

Comments:

LOCATION: N Main St btwn Clifford Ct and Illinois St **QC JOB #:** 16302723
SPECIFIC LOCATION: **DIRECTION:** SB
CITY/STATE: Newberg, OR **DATE:** Sep 12 2023 - Sep 18 2023

Start Time	Bikes	Cars & Trailers	2 Axle Long	Buses	2 Axle 6 Tire	3 Axle Single	4 Axle Single	<5 Axl Double	5 Axle Double	>6 Axl Double	<6 Axl Multi	6 Axle Multi	>6 Axl Multi	Not Classed	Total
Grand Total	56	4385	1746	40	917	9	1	75	3	0	0	0	0	175	7407
Percent	0.8%	59.2%	23.6%	0.5%	12.4%	0.1%	0%	1%	0%	0%	0%	0%	0%	2.4%	



Comments:

LOCATION: N Main St btwn Clifford Ct and Illinois St

QC JOB #: 16302723

SPECIFIC LOCATION:

DIRECTION: NB

CITY/STATE: Newberg, OR

DATE: Sep 12 2023

Start Time	Bikes	Cars & Trailers	2 Axle Long	Buses	2 Axle 6 Tire	3 Axle Single	4 Axle Single	<5 Axl Double	5 Axle Double	>6 Axl Double	<6 Axl Multi	6 Axle Multi	>6 Axl Multi	Not Classed	Total
12:00 AM	0	0	0	0	1	0	0	0	0	0	0	0	0	0	1
01:00 AM	0	1	1	0	0	0	0	0	0	0	0	0	0	0	2
02:00 AM	0	1	0	0	1	0	0	0	0	0	0	0	0	0	2
03:00 AM	0	0	0	0	0	0	0	0	0	0	0	0	0	0	0
04:00 AM	0	0	0	0	0	0	0	0	0	0	0	0	0	0	0
05:00 AM	0	3	2	0	0	0	0	0	0	0	0	0	0	0	5
06:00 AM	0	13	7	0	1	0	0	2	0	0	0	0	0	0	23
07:00 AM	1	42	16	2	7	0	0	1	0	0	0	0	0	0	69
08:00 AM	0	27	12	3	10	0	0	3	0	0	0	0	0	4	59
09:00 AM	0	22	19	0	10	0	0	1	0	0	0	0	0	8	60
10:00 AM	0	35	13	1	7	2	0	0	0	0	0	0	0	1	59
11:00 AM	0	37	19	1	9	0	0	1	0	0	0	0	0	2	69
12:00 PM	0	38	21	0	12	1	0	0	0	0	0	0	0	2	74
01:00 PM	0	40	20	0	13	0	0	1	0	0	0	0	0	3	77
02:00 PM	0	32	22	5	15	0	0	2	1	0	0	0	0	1	78
03:00 PM	0	63	17	1	16	0	0	0	0	0	0	0	0	4	101
04:00 PM	0	66	52	1	13	1	0	2	0	0	0	0	0	5	140
05:00 PM	2	97	41	0	23	1	0	0	0	0	0	0	0	5	169
06:00 PM	0	66	26	0	7	0	0	0	0	0	0	0	0	4	103
07:00 PM	0	57	18	0	12	0	0	0	0	0	0	0	0	3	90
08:00 PM	0	26	13	0	7	0	0	0	0	0	0	0	0	0	46
09:00 PM	0	18	7	0	2	0	0	0	0	0	0	0	0	1	28
10:00 PM	0	9	3	0	1	0	0	0	0	0	0	0	0	0	13
11:00 PM	0	3	1	0	0	0	0	0	0	0	0	0	0	0	4
Day Total	3	696	330	14	167	5	0	13	1	0	0	0	0	43	1272
Percent	0.2%	54.7%	25.9%	1.1%	13.1%	0.4%	0%	1%	0.1%	0%	0%	0%	0%	3.4%	
ADT 1272															
AM Peak Volume	7:00 AM 1	7:00 AM 42	9:00 AM 19	8:00 AM 3	8:00 AM 10	10:00 AM 2	12:00 AM 0	8:00 AM 3	12:00 AM 0	12:00 AM 0	12:00 AM 0	12:00 AM 0	12:00 AM 0	9:00 AM 8	7:00 AM 69
PM Peak Volume	5:00 PM 2	5:00 PM 97	4:00 PM 52	2:00 PM 5	5:00 PM 23	12:00 PM 1	12:00 PM 0	2:00 PM 2	2:00 PM 1	12:00 PM 0	12:00 PM 0	12:00 PM 0	12:00 PM 0	4:00 PM 5	5:00 PM 169

Comments:

LOCATION: N Main St btwn Clifford Ct and Illinois St

QC JOB #: 16302723

SPECIFIC LOCATION:

DIRECTION: NB

CITY/STATE: Newberg, OR

DATE: Sep 13 2023

Start Time	Bikes	Cars & Trailers	2 Axle Long	Buses	2 Axle 6 Tire	3 Axle Single	4 Axle Single	<5 Axl Double	5 Axle Double	>6 Axl Double	<6 Axl Multi	6 Axle Multi	>6 Axl Multi	Not Classed	Total
12:00 AM	0	4	1	0	0	0	0	0	0	0	0	0	0	0	5
01:00 AM	0	0	0	0	0	0	0	0	0	0	0	0	0	0	0
02:00 AM	0	1	1	0	1	0	0	0	0	0	0	0	0	0	3
03:00 AM	0	2	0	0	0	0	0	0	0	0	0	0	0	0	2
04:00 AM	0	0	1	0	0	0	0	0	0	0	0	0	0	0	1
05:00 AM	0	2	4	0	0	0	0	0	0	0	0	0	0	0	6
06:00 AM	0	13	5	0	1	0	0	1	0	0	0	0	0	1	21
07:00 AM	0	36	6	0	5	0	0	1	0	0	0	0	0	0	48
08:00 AM	0	36	24	0	5	0	0	4	0	0	0	0	0	7	76
09:00 AM	0	29	18	4	9	0	0	1	0	0	0	0	0	3	64
10:00 AM	0	26	15	0	8	0	0	1	0	0	0	0	0	4	54
11:00 AM	0	40	19	1	11	0	0	3	0	0	0	0	0	1	75
12:00 PM	1	37	20	0	5	0	0	0	0	0	0	0	0	1	64
01:00 PM	1	40	19	0	12	0	0	1	0	0	0	0	0	2	75
02:00 PM	0	47	21	3	13	0	0	1	0	0	0	0	0	2	87
03:00 PM	1	68	30	1	16	0	0	1	0	0	0	0	0	4	121
04:00 PM	1	88	57	0	20	0	0	0	0	0	0	0	0	7	173
05:00 PM	3	118	39	0	19	2	0	0	0	0	0	0	0	6	187
06:00 PM	0	77	19	0	11	0	0	1	0	0	0	0	0	2	110
07:00 PM	2	56	14	0	16	0	0	0	0	0	0	0	0	4	92
08:00 PM	1	32	10	0	7	0	0	1	0	0	0	0	0	0	51
09:00 PM	0	18	13	0	2	0	0	0	0	0	0	0	0	1	34
10:00 PM	0	8	1	0	1	0	0	0	0	0	0	0	0	0	10
11:00 PM	0	5	0	0	2	0	0	0	0	0	0	0	0	0	7
Day Total	10	783	337	9	164	2	0	16	0	0	0	0	0	45	1366
Percent	0.7%	57.3%	24.7%	0.7%	12%	0.1%	0%	1.2%	0%	0%	0%	0%	0%	3.3%	
ADT 1366															
AM Peak Volume	12:00 AM	11:00 AM	8:00 AM	9:00 AM	11:00 AM	12:00 AM	12:00 AM	8:00 AM	12:00 AM	12:00 AM	12:00 AM	12:00 AM	12:00 AM	8:00 AM	8:00 AM
	0	40	24	4	11	0	0	4	0	0	0	0	0	7	76
PM Peak Volume	5:00 PM	5:00 PM	4:00 PM	2:00 PM	4:00 PM	5:00 PM	12:00 PM	1:00 PM	12:00 PM	12:00 PM	12:00 PM	12:00 PM	12:00 PM	4:00 PM	5:00 PM
	3	118	57	3	20	2	0	1	0	0	0	0	0	7	187

Comments:

LOCATION: N Main St btwn Clifford Ct and Illinois St
SPECIFIC LOCATION:
CITY/STATE: Newberg, OR

QC JOB #: 16302723
DIRECTION: NB
DATE: Sep 14 2023

Start Time	Bikes	Cars & Trailers	2 Axle Long	Buses	2 Axle 6 Tire	3 Axle Single	4 Axle Single	<5 Axl Double	5 Axle Double	>6 Axl Double	<6 Axl Multi	6 Axle Multi	>6 Axl Multi	Not Classed	Total
12:00 AM	0	0	0	0	0	0	0	0	0	0	0	0	0	0	0
01:00 AM	0	0	0	0	0	0	0	0	0	0	0	0	0	0	0
02:00 AM	0	0	0	0	0	0	0	0	0	0	0	0	0	0	0
03:00 AM	0	0	0	0	0	0	0	0	0	0	0	0	0	0	0
04:00 AM	0	1	3	0	0	0	0	0	0	0	0	0	0	0	4
05:00 AM	0	3	6	0	0	0	0	0	0	0	0	0	0	0	9
06:00 AM	0	12	5	0	4	0	0	0	0	0	0	0	0	3	24
07:00 AM	0	43	12	1	4	0	0	1	0	0	0	0	0	0	61
08:00 AM	0	31	11	3	10	0	0	1	0	0	0	0	0	4	60
09:00 AM	0	18	14	0	5	1	0	2	0	0	0	0	0	2	42
10:00 AM	0	22	13	0	11	0	0	1	0	0	0	0	0	1	48
11:00 AM	0	47	16	1	11	0	0	0	0	0	0	0	0	1	76
12:00 PM	0	50	19	0	11	0	0	1	0	0	0	0	0	1	82
01:00 PM	0	48	18	0	18	0	0	1	0	0	0	0	0	1	86
02:00 PM	0	58	14	3	15	0	0	0	0	0	0	0	0	2	92
03:00 PM	0	43	30	1	17	0	0	0	0	0	0	0	0	4	95
04:00 PM	0	72	40	0	11	1	0	0	0	0	0	0	0	6	130
05:00 PM	2	88	41	0	22	0	0	2	0	0	0	0	0	5	160
06:00 PM	1	60	22	0	13	0	0	0	0	0	0	0	0	4	100
07:00 PM	0	39	15	0	10	0	0	0	0	0	0	0	0	2	66
08:00 PM	1	45	7	0	5	0	0	2	0	0	0	0	0	1	61
09:00 PM	0	15	6	0	4	0	0	0	0	0	0	0	0	0	25
10:00 PM	0	8	8	0	2	0	0	0	0	0	0	0	0	0	18
11:00 PM	0	2	0	0	1	0	0	0	0	0	0	0	0	1	4
Day Total	4	705	300	9	174	2	0	11	0	0	0	0	0	38	1243
Percent	0.3%	56.7%	24.1%	0.7%	14%	0.2%	0%	0.9%	0%	0%	0%	0%	0%	3.1%	
ADT 1243															
AM Peak Volume	12:00 AM	11:00 AM	11:00 AM	8:00 AM	10:00 AM	9:00 AM	12:00 AM	9:00 AM	12:00 AM	12:00 AM	12:00 AM	12:00 AM	12:00 AM	8:00 AM	11:00 AM
	0	47	16	3	11	1	0	2	0	0	0	0	0	4	76
PM Peak Volume	5:00 PM	5:00 PM	5:00 PM	2:00 PM	5:00 PM	4:00 PM	12:00 PM	5:00 PM	12:00 PM	12:00 PM	12:00 PM	12:00 PM	12:00 PM	4:00 PM	5:00 PM
	2	88	41	3	22	1	0	2	0	0	0	0	0	6	160

Comments:

LOCATION: N Main St btwn Clifford Ct and Illinois St
SPECIFIC LOCATION:
CITY/STATE: Newberg, OR

QC JOB #: 16302723
DIRECTION: NB
DATE: Sep 15 2023

Start Time	Bikes	Cars & Trailers	2 Axle Long	Buses	2 Axle 6 Tire	3 Axle Single	4 Axle Single	<5 Axl Double	5 Axle Double	>6 Axl Double	<6 Axl Multi	6 Axle Multi	>6 Axl Multi	Not Classed	Total
12:00 AM	0	4	1	0	0	0	0	0	0	0	0	0	0	0	5
01:00 AM	0	1	0	0	0	0	0	0	0	0	0	0	0	0	1
02:00 AM	0	0	0	0	0	0	0	0	0	0	0	0	0	0	0
03:00 AM	0	1	0	0	0	0	0	0	0	0	0	0	0	0	1
04:00 AM	0	1	0	0	0	0	0	0	0	0	0	0	0	0	1
05:00 AM	0	1	3	0	0	0	0	0	0	0	0	0	0	0	4
06:00 AM	0	19	4	0	3	0	0	0	0	0	0	0	0	0	26
07:00 AM	0	33	9	1	5	0	0	3	0	0	0	0	0	2	53
08:00 AM	2	35	16	4	8	0	0	0	0	0	0	0	0	0	65
09:00 AM	0	23	9	0	13	0	0	3	0	0	0	0	0	3	51
10:00 AM	0	35	14	1	7	0	0	1	0	0	0	0	0	1	59
11:00 AM	0	31	16	0	12	0	0	0	0	0	0	0	0	5	64
12:00 PM	0	40	19	0	7	0	0	3	0	0	0	0	0	1	70
01:00 PM	0	43	25	0	14	0	0	1	0	0	0	0	0	2	85
02:00 PM	0	52	19	2	18	0	0	3	0	0	0	0	0	8	102
03:00 PM	0	74	23	1	14	0	0	2	0	0	0	0	0	4	118
04:00 PM	0	64	30	0	17	1	0	3	0	0	0	0	0	6	121
05:00 PM	0	91	32	0	14	0	0	1	0	0	0	0	0	6	144
06:00 PM	0	43	22	0	11	0	0	1	0	0	0	0	0	3	80
07:00 PM	1	54	18	0	12	0	0	1	0	0	0	0	0	1	87
08:00 PM	0	36	19	0	4	0	0	0	0	0	0	0	0	1	60
09:00 PM	0	23	9	0	5	0	0	0	0	0	0	0	0	0	37
10:00 PM	0	13	3	0	1	0	0	0	0	0	0	0	0	0	17
11:00 PM	0	11	5	0	1	0	0	0	0	0	0	0	0	0	17
Day Total	3	728	296	9	166	1	0	22	0	0	0	0	0	43	1268
Percent	0.2%	57.4%	23.3%	0.7%	13.1%	0.1%	0%	1.7%	0%	0%	0%	0%	0%	3.4%	
ADT 1268															
AM Peak Volume	8:00 AM 2	8:00 AM 35	8:00 AM 16	8:00 AM 4	9:00 AM 13	12:00 AM 0	12:00 AM 0	7:00 AM 3	12:00 AM 0	12:00 AM 0	12:00 AM 0	12:00 AM 0	12:00 AM 0	11:00 AM 5	8:00 AM 65
PM Peak Volume	7:00 PM 1	5:00 PM 91	5:00 PM 32	2:00 PM 2	2:00 PM 18	4:00 PM 1	12:00 PM 0	12:00 PM 3	12:00 PM 0	12:00 PM 0	12:00 PM 0	12:00 PM 0	12:00 PM 0	2:00 PM 8	5:00 PM 144

Comments:

LOCATION: N Main St btwn Clifford Ct and Illinois St

QC JOB #: 16302723

SPECIFIC LOCATION:

DIRECTION: NB

CITY/STATE: Newberg, OR

DATE: Sep 16 2023

Start Time	Bikes	Cars & Trailers	2 Axle Long	Buses	2 Axle 6 Tire	3 Axle Single	4 Axle Single	<5 Axl Double	5 Axle Double	>6 Axl Double	<6 Axl Multi	6 Axle Multi	>6 Axl Multi	Not Classed	Total
12:00 AM	0	2	0	0	1	0	0	0	0	0	0	0	0	0	3
01:00 AM	0	2	0	0	0	0	0	0	0	0	0	0	0	0	2
02:00 AM	0	3	1	0	0	0	0	0	0	0	0	0	0	0	4
03:00 AM	0	1	1	0	0	0	0	0	0	0	0	0	0	0	2
04:00 AM	0	2	1	0	0	0	0	0	0	0	0	0	0	0	3
05:00 AM	0	2	2	0	0	0	0	0	0	0	0	0	0	0	4
06:00 AM	0	9	5	0	3	0	0	0	0	0	0	0	0	0	17
07:00 AM	0	12	4	0	1	0	0	0	0	0	0	0	0	0	17
08:00 AM	0	85	35	0	24	0	0	1	0	0	0	0	0	2	147
09:00 AM	1	87	48	0	14	0	0	1	0	0	0	0	0	4	155
10:00 AM	1	80	37	0	15	0	0	2	0	0	0	0	0	10	145
11:00 AM	0	66	33	0	15	1	0	1	0	0	0	0	0	4	120
12:00 PM	0	43	21	0	8	1	0	2	0	0	0	0	0	8	83
01:00 PM	1	63	42	0	12	0	0	0	0	0	0	0	0	5	123
02:00 PM	0	57	25	0	12	0	0	0	0	0	0	0	0	2	96
03:00 PM	2	48	22	0	12	1	0	1	0	0	0	0	0	6	92
04:00 PM	1	52	25	0	11	0	0	1	0	0	0	0	0	2	92
05:00 PM	1	57	16	0	8	2	0	0	0	0	0	0	0	5	89
06:00 PM	1	51	18	0	5	1	0	0	0	0	0	0	0	1	77
07:00 PM	0	44	12	0	4	0	0	1	0	0	0	0	0	1	62
08:00 PM	1	35	11	0	8	0	0	0	0	0	0	0	0	0	55
09:00 PM	0	23	10	0	6	0	0	0	0	0	0	0	0	2	41
10:00 PM	0	19	3	0	2	0	0	0	0	0	0	0	0	0	24
11:00 PM	0	13	5	0	1	0	0	0	0	0	0	0	0	0	19
Day Total	9	856	377	0	162	6	0	10	0	0	0	0	0	52	1472
Percent	0.6%	58.2%	25.6%	0%	11%	0.4%	0%	0.7%	0%	0%	0%	0%	0%	3.5%	
ADT 1472															
AM Peak Volume	9:00 AM 1	9:00 AM 87	9:00 AM 48	12:00 AM 0	8:00 AM 24	11:00 AM 1	12:00 AM 0	10:00 AM 2	12:00 AM 0	12:00 AM 0	12:00 AM 0	12:00 AM 0	12:00 AM 0	10:00 AM 10	9:00 AM 155
PM Peak Volume	3:00 PM 2	1:00 PM 63	1:00 PM 42	12:00 PM 0	1:00 PM 12	5:00 PM 2	12:00 PM 0	12:00 PM 2	12:00 PM 0	12:00 PM 0	12:00 PM 0	12:00 PM 0	12:00 PM 0	12:00 PM 8	1:00 PM 123

Comments:

LOCATION: N Main St btwn Clifford Ct and Illinois St
SPECIFIC LOCATION:
CITY/STATE: Newberg, OR

QC JOB #: 16302723
DIRECTION: NB
DATE: Sep 17 2023

Start Time	Bikes	Cars & Trailers	2 Axle Long	Buses	2 Axle 6 Tire	3 Axle Single	4 Axle Single	<5 Axl Double	5 Axle Double	>6 Axl Double	<6 Axl Multi	6 Axle Multi	>6 Axl Multi	Not Classed	Total
12:00 AM	0	13	5	0	1	0	0	0	0	0	0	0	0	0	19
01:00 AM	0	2	0	0	0	0	0	0	0	0	0	0	0	0	2
02:00 AM	0	3	1	0	1	0	0	0	0	0	0	0	0	0	5
03:00 AM	0	4	0	0	0	0	0	0	0	0	0	0	0	0	4
04:00 AM	0	1	0	0	0	0	0	0	0	0	0	0	0	0	1
05:00 AM	0	1	2	0	0	0	0	0	0	0	0	0	0	0	3
06:00 AM	0	11	5	0	3	0	0	0	0	0	0	0	0	1	20
07:00 AM	0	34	21	0	9	0	0	0	0	0	0	0	0	1	65
08:00 AM	0	25	13	0	13	0	0	0	0	0	0	0	0	1	52
09:00 AM	1	31	17	0	13	0	0	1	0	0	0	0	0	3	66
10:00 AM	0	53	26	0	13	0	0	1	0	0	0	0	0	0	93
11:00 AM	0	72	22	1	18	0	0	1	0	0	0	0	0	4	118
12:00 PM	1	82	32	0	19	0	0	0	0	0	0	0	0	9	143
01:00 PM	0	79	31	0	11	0	0	1	0	0	0	0	0	3	125
02:00 PM	1	52	18	0	19	0	0	0	0	0	0	0	0	6	96
03:00 PM	0	54	24	0	11	0	0	0	0	0	0	0	0	2	91
04:00 PM	0	64	20	0	12	0	0	1	0	0	0	0	0	0	97
05:00 PM	3	61	26	0	10	0	0	0	0	0	0	0	0	6	106
06:00 PM	0	49	18	0	3	0	0	0	0	0	0	0	0	3	73
07:00 PM	1	46	12	0	12	0	0	0	0	0	0	0	0	1	72
08:00 PM	0	28	13	0	5	0	0	0	0	0	0	0	0	1	47
09:00 PM	0	14	5	0	1	0	0	0	0	0	0	0	0	1	21
10:00 PM	0	9	4	0	0	0	0	0	0	0	0	0	0	0	13
11:00 PM	0	5	1	0	1	0	0	0	0	0	0	0	0	0	7
Day Total	7	793	316	1	175	0	0	5	0	0	0	0	0	42	1339
Percent	0.5%	59.2%	23.6%	0.1%	13.1%	0%	0%	0.4%	0%	0%	0%	0%	0%	3.1%	
ADT 1339															
AM Peak Volume	9:00 AM	11:00 AM	10:00 AM	11:00 AM	11:00 AM	12:00 AM	12:00 AM	9:00 AM	12:00 AM	12:00 AM	12:00 AM	12:00 AM	12:00 AM	11:00 AM	11:00 AM
	1	72	26	1	18	0	0	1	0	0	0	0	0	4	118
PM Peak Volume	5:00 PM	12:00 PM	12:00 PM	12:00 PM	12:00 PM	12:00 PM	12:00 PM	1:00 PM	12:00 PM	12:00 PM	12:00 PM	12:00 PM	12:00 PM	12:00 PM	12:00 PM
	3	82	32	0	19	0	0	1	0	0	0	0	0	9	143

Comments:

LOCATION: N Main St btwn Clifford Ct and Illinois St **QC JOB #:** 16302723
SPECIFIC LOCATION: **DIRECTION:** NB
CITY/STATE: Newberg, OR **DATE:** Sep 18 2023

Start Time	Bikes	Cars & Trailers	2 Axle Long	Buses	2 Axle 6 Tire	3 Axle Single	4 Axle Single	<5 Axl Double	5 Axle Double	>6 Axl Double	<6 Axl Multi	6 Axle Multi	>6 Axl Multi	Not Classed	Total
12:00 AM	0	2	0	0	0	0	0	0	0	0	0	0	0	0	2
01:00 AM	0	1	2	0	0	0	0	0	0	0	0	0	0	0	3
02:00 AM	0	0	0	0	0	0	0	0	0	0	0	0	0	1	1
03:00 AM	0	0	0	0	0	0	0	0	0	0	0	0	0	0	0
04:00 AM	0	1	0	0	0	0	0	0	0	0	0	0	0	0	1
05:00 AM	0	2	4	0	0	0	0	0	0	0	0	0	0	0	6
06:00 AM	0	9	5	0	4	0	0	0	0	0	0	0	0	0	18
07:00 AM	0	42	19	0	6	0	0	2	0	0	0	0	0	2	71
08:00 AM	0	35	13	3	7	0	0	1	0	0	0	0	0	0	59
09:00 AM	0	27	12	0	16	0	0	2	0	0	0	0	0	4	61
10:00 AM	0	34	17	0	7	0	0	1	0	0	0	0	0	3	62
11:00 AM	0	35	12	0	7	0	0	2	0	0	0	0	0	3	59
12:00 PM	0	32	14	0	12	0	0	0	0	0	0	0	0	0	58
01:00 PM	0	59	12	0	16	0	0	2	0	0	0	0	0	5	94
02:00 PM	0	42	14	3	10	0	0	0	1	0	0	0	0	3	73
03:00 PM	0	57	13	1	14	2	0	0	0	0	0	0	0	4	91
04:00 PM	0	69	37	0	15	0	0	0	0	0	0	0	0	6	127
05:00 PM	0	78	31	0	19	0	0	0	0	0	0	0	0	5	133
06:00 PM	1	62	25	0	11	0	0	0	0	0	0	0	0	3	102
07:00 PM	0	40	12	0	6	0	0	0	0	0	0	0	0	1	59
08:00 PM	0	28	6	0	5	0	0	0	0	0	0	0	0	0	39
09:00 PM	0	24	5	0	7	0	0	0	0	0	0	0	0	0	36
10:00 PM	0	10	4	0	1	0	0	0	0	0	0	0	0	0	15
11:00 PM	0	2	1	0	0	0	0	0	0	0	0	0	0	0	3
Day Total	1	691	258	7	163	2	0	10	1	0	0	0	0	40	1173
Percent	0.1%	58.9%	22%	0.6%	13.9%	0.2%	0%	0.9%	0.1%	0%	0%	0%	0%	3.4%	
ADT 1173															
AM Peak Volume	12:00 AM	7:00 AM	7:00 AM	8:00 AM	9:00 AM	12:00 AM	12:00 AM	7:00 AM	12:00 AM	12:00 AM	12:00 AM	12:00 AM	12:00 AM	9:00 AM	7:00 AM
	0	42	19	3	16	0	0	2	0	0	0	0	0	4	71
PM Peak Volume	6:00 PM	5:00 PM	4:00 PM	2:00 PM	5:00 PM	3:00 PM	12:00 PM	1:00 PM	2:00 PM	12:00 PM	12:00 PM	12:00 PM	12:00 PM	4:00 PM	5:00 PM
	1	78	37	3	19	2	0	2	1	0	0	0	0	6	133

Comments:

LOCATION: N Main St btwn Clifford Ct and Illinois St **QC JOB #:** 16302723
SPECIFIC LOCATION: **DIRECTION:** NB
CITY/STATE: Newberg, OR **DATE:** Sep 12 2023 - Sep 18 2023

Start Time	Bikes	Cars & Trailers	2 Axle Long	Buses	2 Axle 6 Tire	3 Axle Single	4 Axle Single	<5 Axl Double	5 Axle Double	>6 Axl Double	<6 Axl Multi	6 Axle Multi	>6 Axl Multi	Not Classed	Total
Grand Total	37	5252	2214	49	1171	18	0	87	2	0	0	0	0	303	9133
Percent	0.4%	57.5%	24.2%	0.5%	12.8%	0.2%	0%	1%	0%	0%	0%	0%	0%	3.3%	



Comments:

LOCATION: E Illinois St btwn Main St and Washington St

QC JOB #: 16302724

SPECIFIC LOCATION:

DIRECTION: WB

CITY/STATE: Newberg, OR

DATE: Sep 12 2023

Start Time	Bikes	Cars & Trailers	2 Axle Long	Buses	2 Axle 6 Tire	3 Axle Single	4 Axle Single	<5 Axl Double	5 Axle Double	>6 Axl Double	<6 Axl Multi	6 Axle Multi	>6 Axl Multi	Not Classed	Total
12:00 AM	0	1	0	0	0	0	0	0	0	0	0	0	0	0	1
01:00 AM	0	5	0	0	1	0	0	0	0	0	0	0	0	0	6
02:00 AM	0	2	3	0	0	0	0	0	0	0	0	0	0	0	5
03:00 AM	0	0	0	0	0	0	0	0	0	0	0	0	0	0	0
04:00 AM	0	0	0	0	1	0	0	0	0	0	0	0	0	0	1
05:00 AM	0	7	2	0	1	0	0	0	0	0	0	0	0	0	10
06:00 AM	0	18	11	0	0	0	0	1	0	0	0	0	0	2	32
07:00 AM	0	35	10	1	8	1	0	0	0	0	0	0	0	2	57
08:00 AM	0	30	18	0	9	0	0	0	0	0	0	0	0	1	58
09:00 AM	0	31	15	0	11	0	0	1	0	0	0	0	0	4	62
10:00 AM	0	31	12	0	8	0	0	1	0	0	0	0	0	1	53
11:00 AM	0	40	13	1	7	0	0	0	0	0	0	0	0	0	61
12:00 PM	0	36	19	0	7	2	0	0	0	0	0	0	0	1	65
01:00 PM	0	46	13	0	7	0	0	1	0	0	0	0	0	3	70
02:00 PM	0	53	21	0	9	0	0	5	0	0	0	0	0	3	91
03:00 PM	0	67	29	0	8	0	0	0	0	0	0	0	0	10	114
04:00 PM	0	62	36	0	15	0	0	1	0	0	0	0	0	2	116
05:00 PM	0	84	25	0	15	0	0	2	0	0	0	0	0	5	131
06:00 PM	1	57	20	1	9	0	0	0	0	0	0	0	0	3	91
07:00 PM	0	44	15	0	8	0	0	0	0	0	0	0	0	0	67
08:00 PM	0	29	12	0	9	0	0	0	0	0	0	0	0	2	52
09:00 PM	0	16	3	0	3	0	0	0	0	0	0	0	0	1	23
10:00 PM	0	12	5	0	2	0	0	0	0	0	0	0	0	0	19
11:00 PM	0	3	1	0	0	0	0	0	0	0	0	0	0	0	4
Day Total	1	709	283	3	138	3	0	12	0	0	0	0	0	40	1189
Percent	0.1%	59.6%	23.8%	0.3%	11.6%	0.3%	0%	1%	0%	0%	0%	0%	0%	3.4%	
ADT 1189															
AM Peak Volume	12:00 AM	11:00 AM	8:00 AM	7:00 AM	9:00 AM	7:00 AM	12:00 AM	6:00 AM	12:00 AM	12:00 AM	12:00 AM	12:00 AM	12:00 AM	9:00 AM	9:00 AM
	0	40	18	1	11	1	0	1	0	0	0	0	0	4	62
PM Peak Volume	6:00 PM	5:00 PM	4:00 PM	6:00 PM	4:00 PM	12:00 PM	12:00 PM	2:00 PM	12:00 PM	12:00 PM	12:00 PM	12:00 PM	12:00 PM	3:00 PM	5:00 PM
	1	84	36	1	15	2	0	5	0	0	0	0	0	10	131

Comments:

Type of report: Tube Count - Vehicle Classification Data

LOCATION: E Illinois St btwn Main St and Washington St

QC JOB #: 16302724

SPECIFIC LOCATION:

DIRECTION: WB

CITY/STATE: Newberg, OR

DATE: Sep 13 2023

Start Time	Bikes	Cars & Trailers	2 Axle Long	Buses	2 Axle 6 Tire	3 Axle Single	4 Axle Single	<5 Axl Double	5 Axle Double	>6 Axl Double	<6 Axl Multi	6 Axle Multi	>6 Axl Multi	Not Classed	Total
12:00 AM	0	3	3	0	0	0	0	0	0	0	0	0	0	0	6
01:00 AM	0	2	1	0	0	0	0	0	0	0	0	0	0	0	3
02:00 AM	0	2	2	0	0	0	0	0	0	0	0	0	0	0	4
03:00 AM	0	0	1	0	0	0	0	0	0	0	0	0	0	0	1
04:00 AM	0	2	0	0	1	0	0	0	0	0	0	0	0	0	3
05:00 AM	0	11	1	0	0	0	0	0	0	0	0	0	0	0	12
06:00 AM	0	15	9	0	3	0	0	0	0	0	0	0	0	0	27
07:00 AM	1	32	9	0	10	1	0	1	0	0	0	0	0	0	54
08:00 AM	0	38	17	0	13	0	0	3	0	0	0	0	0	1	72
09:00 AM	0	51	22	0	10	0	0	2	0	0	0	0	0	2	87
10:00 AM	0	36	17	1	8	0	1	0	0	0	0	0	0	0	63
11:00 AM	0	52	17	1	6	0	0	3	0	0	0	0	0	1	80
12:00 PM	0	41	22	0	7	0	0	1	0	0	0	0	0	1	72
01:00 PM	0	37	15	0	11	0	0	1	0	0	0	0	0	1	65
02:00 PM	0	39	28	0	11	0	0	1	0	0	0	0	0	3	82
03:00 PM	0	90	39	0	15	1	0	1	0	0	0	0	0	3	149
04:00 PM	0	78	30	0	13	0	0	0	0	0	0	0	0	5	126
05:00 PM	0	75	17	0	11	0	0	0	0	0	0	0	0	2	105
06:00 PM	0	55	19	0	6	0	0	1	0	0	0	0	0	5	86
07:00 PM	0	42	15	0	4	0	0	0	0	0	0	0	0	1	62
08:00 PM	0	30	10	0	4	0	0	1	0	0	0	0	0	1	46
09:00 PM	0	15	2	0	4	0	0	0	0	0	0	0	0	2	23
10:00 PM	0	13	2	0	2	0	0	0	0	0	0	0	0	0	17
11:00 PM	0	5	4	0	0	0	0	0	0	0	0	0	0	0	9
Day Total	1	764	302	2	139	2	1	15	0	0	0	0	0	28	1254
Percent	0.1%	60.9%	24.1%	0.2%	11.1%	0.2%	0.1%	1.2%	0%	0%	0%	0%	0%	2.2%	
ADT 1254															
AM Peak	7:00 AM	11:00 AM	9:00 AM	10:00 AM	8:00 AM	7:00 AM	10:00 AM	8:00 AM	12:00 AM	12:00 AM	12:00 AM	12:00 AM	12:00 AM	9:00 AM	9:00 AM
Volume	1	52	22	1	13	1	1	3	0	0	0	0	0	2	87
PM Peak	12:00 PM	3:00 PM	3:00 PM	12:00 PM	3:00 PM	3:00 PM	12:00 PM	12:00 PM	12:00 PM	12:00 PM	12:00 PM	12:00 PM	12:00 PM	4:00 PM	3:00 PM
Volume	0	90	39	0	15	1	0	1	0	0	0	0	0	5	149

Comments:

Report generated on 9/22/2023 2:43 PM

SOURCE: Quality Counts, LLC (<http://www.qualitycounts.net>)

Type of report: Tube Count - Vehicle Classification Data

LOCATION: E Illinois St btwn Main St and Washington St
SPECIFIC LOCATION:
CITY/STATE: Newberg, OR

QC JOB #: 16302724
DIRECTION: WB
DATE: Sep 14 2023

Start Time	Bikes	Cars & Trailers	2 Axle Long	Buses	2 Axle 6 Tire	3 Axle Single	4 Axle Single	<5 Axl Double	5 Axle Double	>6 Axl Double	<6 Axl Multi	6 Axle Multi	>6 Axl Multi	Not Classed	Total
12:00 AM	0	2	0	0	2	0	0	0	0	0	0	0	0	0	4
01:00 AM	0	3	0	0	0	0	0	0	0	0	0	0	0	0	3
02:00 AM	0	3	1	0	0	0	0	0	0	0	0	0	0	0	4
03:00 AM	0	1	0	0	0	0	0	0	0	0	0	0	0	0	1
04:00 AM	0	1	0	0	0	0	0	0	0	0	0	0	0	0	1
05:00 AM	0	6	4	0	2	0	0	0	0	0	0	0	0	2	14
06:00 AM	0	22	13	0	1	0	0	0	0	0	0	0	0	0	36
07:00 AM	0	37	13	1	10	0	0	0	0	0	0	0	0	0	61
08:00 AM	0	42	17	0	10	0	0	3	0	0	0	0	0	2	74
09:00 AM	0	26	11	1	10	0	0	0	0	0	0	0	0	1	49
10:00 AM	0	41	11	0	6	0	0	1	0	0	0	0	0	0	59
11:00 AM	0	48	12	0	8	0	0	0	0	0	0	0	0	0	68
12:00 PM	0	49	17	0	11	0	0	1	0	0	0	0	0	8	86
01:00 PM	0	35	16	0	11	0	0	2	1	0	0	0	0	3	68
02:00 PM	0	66	23	1	5	0	0	0	0	0	0	0	0	0	95
03:00 PM	0	67	37	0	15	0	0	1	0	0	0	0	0	5	125
04:00 PM	0	78	27	0	14	0	0	1	0	0	0	0	0	2	122
05:00 PM	1	82	29	0	11	1	0	0	0	0	0	0	0	6	130
06:00 PM	0	58	21	0	15	0	0	0	0	0	0	0	0	1	95
07:00 PM	0	44	8	0	7	0	0	0	0	0	0	0	0	2	61
08:00 PM	0	39	9	1	3	0	0	0	0	0	0	0	0	5	57
09:00 PM	0	26	4	0	1	0	0	0	0	0	0	0	0	1	32
10:00 PM	0	13	2	0	2	0	0	0	0	0	0	0	0	0	17
11:00 PM	0	7	3	0	2	0	0	0	0	0	0	0	0	0	12
Day Total	1	796	278	4	146	1	0	9	1	0	0	0	0	38	1274
Percent	0.1%	62.5%	21.8%	0.3%	11.5%	0.1%	0%	0.7%	0.1%	0%	0%	0%	0%	3%	
ADT 1274															
AM Peak Volume	12:00 AM 0	11:00 AM 48	8:00 AM 17	7:00 AM 1	7:00 AM 10	12:00 AM 0	12:00 AM 0	8:00 AM 3	12:00 AM 0	12:00 AM 0	12:00 AM 0	12:00 AM 0	12:00 AM 0	5:00 AM 2	8:00 AM 74
PM Peak Volume	5:00 PM 1	5:00 PM 82	3:00 PM 37	2:00 PM 1	3:00 PM 15	5:00 PM 1	12:00 PM 0	1:00 PM 2	1:00 PM 1	12:00 PM 0	12:00 PM 0	12:00 PM 0	12:00 PM 0	12:00 PM 8	5:00 PM 130

Comments:

LOCATION: E Illinois St btwn Main St and Washington St **QC JOB #:** 16302724
SPECIFIC LOCATION: **DIRECTION:** WB
CITY/STATE: Newberg, OR **DATE:** Sep 15 2023

Start Time	Bikes	Cars & Trailers	2 Axle Long	Buses	2 Axle 6 Tire	3 Axle Single	4 Axle Single	<5 Axl Double	5 Axle Double	>6 Axl Double	<6 Axl Multi	6 Axle Multi	>6 Axl Multi	Not Classed	Total
12:00 AM	0	2	1	0	0	0	0	0	0	0	0	0	0	0	3
01:00 AM	0	2	0	0	0	0	0	0	0	0	0	0	0	0	2
02:00 AM	0	2	1	0	0	0	0	0	0	0	0	0	0	0	3
03:00 AM	0	0	0	0	0	0	0	0	0	0	0	0	0	0	0
04:00 AM	0	0	0	0	0	0	0	0	0	0	0	0	0	0	0
05:00 AM	0	5	1	0	1	0	0	0	0	0	0	0	0	0	7
06:00 AM	0	14	10	0	4	0	0	1	0	0	0	0	0	1	30
07:00 AM	1	40	13	0	10	2	0	0	0	0	0	0	0	0	66
08:00 AM	0	39	23	0	11	0	0	2	0	0	0	0	0	1	76
09:00 AM	0	27	10	1	12	1	0	2	0	0	0	0	0	2	55
10:00 AM	0	26	12	0	6	1	0	0	0	0	0	0	0	5	50
11:00 AM	0	50	14	0	12	0	0	0	0	0	0	0	0	2	78
12:00 PM	0	43	13	0	13	0	0	1	0	0	0	0	0	2	72
01:00 PM	0	32	19	0	16	0	0	1	0	0	0	0	0	1	69
02:00 PM	0	59	29	1	14	0	0	0	0	0	0	0	0	1	104
03:00 PM	0	77	44	0	13	1	0	1	0	0	0	0	0	5	141
04:00 PM	0	80	23	0	9	0	0	1	0	0	0	0	0	3	116
05:00 PM	0	63	29	0	16	0	0	1	0	0	0	0	0	3	112
06:00 PM	0	49	18	0	12	0	0	0	1	0	0	0	0	2	82
07:00 PM	0	41	10	0	8	0	0	0	0	0	0	0	0	2	61
08:00 PM	0	25	8	0	7	0	0	0	0	0	0	0	0	3	43
09:00 PM	0	20	2	0	3	0	0	0	0	0	0	0	0	0	25
10:00 PM	0	7	4	0	2	0	0	0	0	0	0	0	0	0	13
11:00 PM	0	8	1	0	0	0	0	0	0	0	0	0	0	1	10
Day Total	1	711	285	2	169	5	0	10	1	0	0	0	0	34	1218
Percent	0.1%	58.4%	23.4%	0.2%	13.9%	0.4%	0%	0.8%	0.1%	0%	0%	0%	0%	2.8%	
ADT 1218															
AM Peak	7:00 AM	11:00 AM	8:00 AM	9:00 AM	9:00 AM	7:00 AM	12:00 AM	8:00 AM	12:00 AM	12:00 AM	12:00 AM	12:00 AM	12:00 AM	10:00 AM	11:00 AM
Volume	1	50	23	1	12	2	0	2	0	0	0	0	0	5	78
PM Peak	12:00 PM	4:00 PM	3:00 PM	2:00 PM	1:00 PM	3:00 PM	12:00 PM	12:00 PM	6:00 PM	12:00 PM	12:00 PM	12:00 PM	12:00 PM	3:00 PM	3:00 PM
Volume	0	80	44	1	16	1	0	1	1	0	0	0	0	5	141

Comments:

LOCATION: E Illinois St btwn Main St and Washington St
SPECIFIC LOCATION:
CITY/STATE: Newberg, OR

QC JOB #: 16302724
DIRECTION: WB
DATE: Sep 16 2023

Start Time	Bikes	Cars & Trailers	2 Axle Long	Buses	2 Axle 6 Tire	3 Axle Single	4 Axle Single	<5 Axl Double	5 Axle Double	>6 Axl Double	<6 Axl Multi	6 Axle Multi	>6 Axl Multi	Not Classed	Total
12:00 AM	0	6	1	0	2	0	0	0	0	0	0	0	0	0	9
01:00 AM	0	1	2	0	0	0	0	0	0	0	0	0	0	0	3
02:00 AM	0	5	1	0	0	0	0	0	0	0	0	0	0	0	6
03:00 AM	0	0	1	0	0	0	0	0	0	0	0	0	0	0	1
04:00 AM	0	2	0	0	1	0	0	0	0	0	0	0	0	0	3
05:00 AM	0	1	2	0	0	0	0	1	0	0	0	0	0	0	4
06:00 AM	0	3	1	0	1	0	0	0	0	0	0	0	0	0	5
07:00 AM	0	10	3	0	6	0	0	0	0	0	0	0	0	1	20
08:00 AM	0	30	13	0	9	1	0	0	0	0	0	0	0	2	55
09:00 AM	0	46	12	0	5	0	0	0	0	0	0	0	0	0	63
10:00 AM	0	49	19	0	16	0	0	1	0	0	0	0	0	2	87
11:00 AM	0	48	12	0	14	0	0	0	0	0	0	0	0	4	78
12:00 PM	0	41	24	0	8	0	0	2	0	0	0	0	0	3	78
01:00 PM	0	38	27	0	6	0	0	1	0	0	0	0	0	4	76
02:00 PM	1	38	17	0	7	1	0	0	0	0	0	0	0	3	67
03:00 PM	0	46	15	0	11	0	0	0	0	0	0	0	0	1	73
04:00 PM	1	46	17	0	5	0	0	0	0	0	0	0	0	2	71
05:00 PM	0	49	25	0	12	0	0	0	0	0	0	0	0	6	92
06:00 PM	0	31	15	0	10	1	0	1	0	0	0	0	0	3	61
07:00 PM	0	29	9	0	4	0	0	0	0	0	0	0	0	1	43
08:00 PM	0	22	5	0	4	0	0	0	0	0	0	0	0	3	34
09:00 PM	0	15	5	0	3	0	0	0	0	0	0	0	0	0	23
10:00 PM	0	11	2	0	0	0	0	0	0	0	0	0	0	0	13
11:00 PM	0	10	2	0	0	0	0	0	0	0	0	0	0	0	12
Day Total	2	577	230	0	124	3	0	6	0	0	0	0	0	35	977
Percent	0.2%	59.1%	23.5%	0%	12.7%	0.3%	0%	0.6%	0%	0%	0%	0%	0%	3.6%	
ADT 977															
AM Peak	12:00 AM	10:00 AM	10:00 AM	12:00 AM	10:00 AM	8:00 AM	12:00 AM	5:00 AM	12:00 AM	12:00 AM	12:00 AM	12:00 AM	12:00 AM	12:00 AM	10:00 AM
Volume	0	49	19	0	16	1	0	1	0	0	0	0	0	4	87
PM Peak	2:00 PM	5:00 PM	1:00 PM	12:00 PM	5:00 PM	2:00 PM	12:00 PM	12:00 PM	12:00 PM	12:00 PM	12:00 PM	12:00 PM	12:00 PM	5:00 PM	5:00 PM
Volume	1	49	27	0	12	1	0	2	0	0	0	0	0	6	92

Comments:

LOCATION: E Illinois St btwn Main St and Washington St **QC JOB #:** 16302724
SPECIFIC LOCATION: **DIRECTION:** WB
CITY/STATE: Newberg, OR **DATE:** Sep 17 2023

Start Time	Bikes	Cars & Trailers	2 Axle Long	Buses	2 Axle 6 Tire	3 Axle Single	4 Axle Single	<5 Axl Double	5 Axle Double	>6 Axl Double	<6 Axl Multi	6 Axle Multi	>6 Axl Multi	Not Classed	Total
12:00 AM	0	5	1	0	0	0	0	0	0	0	0	0	0	0	6
01:00 AM	0	2	0	0	0	0	0	0	0	0	0	0	0	0	2
02:00 AM	0	1	0	0	0	0	0	0	0	0	0	0	0	0	1
03:00 AM	0	3	0	0	1	0	0	0	0	0	0	0	0	0	4
04:00 AM	0	2	0	0	3	0	0	1	0	0	0	0	0	0	6
05:00 AM	0	2	0	0	0	0	0	0	0	0	0	0	0	0	2
06:00 AM	0	7	4	0	0	0	0	0	0	0	0	0	0	0	11
07:00 AM	0	14	3	0	2	0	0	0	0	0	0	0	0	2	21
08:00 AM	0	12	4	0	3	0	0	0	0	0	0	0	0	0	19
09:00 AM	0	33	17	0	5	0	0	0	0	0	0	0	0	2	57
10:00 AM	0	48	15	0	8	0	0	1	0	0	0	0	0	0	72
11:00 AM	0	46	13	0	8	0	0	3	0	0	0	0	0	6	76
12:00 PM	0	44	20	0	8	0	0	1	0	0	0	0	0	7	80
01:00 PM	0	49	16	0	9	0	0	0	0	0	0	0	0	8	82
02:00 PM	0	46	20	0	7	0	0	0	0	0	0	0	0	2	75
03:00 PM	0	34	13	0	8	0	0	0	0	0	0	0	0	2	57
04:00 PM	1	45	16	0	8	0	0	0	0	0	0	0	0	1	71
05:00 PM	0	38	16	0	12	0	0	0	0	0	0	0	0	1	67
06:00 PM	0	40	13	0	7	0	0	0	0	0	0	0	0	0	60
07:00 PM	1	36	17	0	3	0	0	0	0	0	0	0	0	5	62
08:00 PM	0	16	11	0	2	0	0	1	0	0	0	0	0	1	31
09:00 PM	0	11	0	0	4	0	0	0	0	0	0	0	0	1	16
10:00 PM	0	6	3	0	0	0	0	0	0	0	0	0	0	0	9
11:00 PM	0	3	2	0	0	0	0	0	0	0	0	0	0	0	5
Day Total	2	543	204	0	98	0	0	7	0	0	0	0	0	38	892
Percent	0.2%	60.9%	22.9%	0%	11%	0%	0%	0.8%	0%	0%	0%	0%	0%	4.3%	
ADT 892															
AM Peak	12:00 AM	10:00 AM	9:00 AM	12:00 AM	10:00 AM	12:00 AM	12:00 AM	11:00 AM	12:00 AM	12:00 AM	12:00 AM	12:00 AM	12:00 AM	11:00 AM	11:00 AM
Volume	0	48	17	0	8	0	0	3	0	0	0	0	0	6	76
PM Peak	4:00 PM	1:00 PM	12:00 PM	12:00 PM	5:00 PM	12:00 PM	12:00 PM	12:00 PM	12:00 PM	12:00 PM	12:00 PM	12:00 PM	12:00 PM	1:00 PM	1:00 PM
Volume	1	49	20	0	12	0	0	1	0	0	0	0	0	8	82

Comments:

LOCATION: E Illinois St btwn Main St and Washington St
SPECIFIC LOCATION:
CITY/STATE: Newberg, OR

QC JOB #: 16302724
DIRECTION: WB
DATE: Sep 18 2023

Start Time	Bikes	Cars & Trailers	2 Axle Long	Buses	2 Axle 6 Tire	3 Axle Single	4 Axle Single	<5 Axl Double	5 Axle Double	>6 Axl Double	<6 Axl Multi	6 Axle Multi	>6 Axl Multi	Not Classed	Total
12:00 AM	0	3	0	0	0	0	0	0	0	0	0	0	0	0	3
01:00 AM	0	2	0	0	0	0	0	0	0	0	0	0	0	0	2
02:00 AM	0	1	0	0	0	0	0	0	0	0	0	0	0	0	1
03:00 AM	0	1	0	0	0	0	0	0	0	0	0	0	0	0	1
04:00 AM	0	2	2	0	1	0	0	0	0	0	0	0	0	0	5
05:00 AM	0	7	3	0	4	0	0	0	0	0	0	0	0	0	14
06:00 AM	0	20	12	0	4	0	0	0	0	0	0	0	0	0	36
07:00 AM	0	31	14	0	11	0	0	0	0	0	0	0	0	1	57
08:00 AM	0	29	21	0	3	1	0	0	0	0	0	0	0	4	58
09:00 AM	0	31	17	0	8	0	0	3	0	0	0	0	0	0	59
10:00 AM	0	30	9	0	7	1	0	0	0	0	0	0	0	3	50
11:00 AM	0	36	15	0	17	0	0	1	0	0	0	0	0	4	73
12:00 PM	0	49	10	0	8	1	0	1	0	0	0	0	0	3	72
01:00 PM	0	36	22	0	14	0	0	1	0	0	0	0	0	5	78
02:00 PM	0	36	27	0	9	0	0	1	0	0	0	0	0	3	76
03:00 PM	1	84	29	0	14	1	0	2	0	0	0	0	0	1	132
04:00 PM	0	76	26	0	18	0	0	0	0	0	0	0	0	3	123
05:00 PM	0	58	38	0	16	0	0	1	0	0	0	0	0	1	114
06:00 PM	0	47	13	0	6	0	0	0	0	0	0	0	0	0	66
07:00 PM	0	41	18	0	7	0	0	0	0	0	0	0	0	2	68
08:00 PM	0	23	11	0	6	0	0	0	0	0	0	0	0	0	40
09:00 PM	0	22	8	0	2	0	0	0	0	0	0	0	0	0	32
10:00 PM	0	3	4	0	0	0	0	0	0	0	0	0	0	1	8
11:00 PM	0	2	0	0	1	0	0	0	0	0	0	0	0	0	3
Day Total	1	670	299	0	156	4	0	10	0	0	0	0	0	31	1171
Percent	0.1%	57.2%	25.5%	0%	13.3%	0.3%	0%	0.9%	0%	0%	0%	0%	0%	2.6%	
ADT 1171															
AM Peak	12:00 AM	11:00 AM	8:00 AM	12:00 AM	11:00 AM	8:00 AM	12:00 AM	9:00 AM	12:00 AM	12:00 AM	12:00 AM	12:00 AM	12:00 AM	8:00 AM	11:00 AM
Volume	0	36	21	0	17	1	0	3	0	0	0	0	0	4	73
PM Peak	3:00 PM	3:00 PM	5:00 PM	12:00 PM	4:00 PM	12:00 PM	12:00 PM	3:00 PM	12:00 PM	12:00 PM	12:00 PM	12:00 PM	12:00 PM	1:00 PM	3:00 PM
Volume	1	84	38	0	18	1	0	2	0	0	0	0	0	5	132

Comments:

LOCATION: E Illinois St btwn Main St and Washington St **QC JOB #:** 16302724
SPECIFIC LOCATION: **DIRECTION:** WB
CITY/STATE: Newberg, OR **DATE:** Sep 12 2023 - Sep 18 2023

Start Time	Bikes	Cars & Trailers	2 Axle Long	Buses	2 Axle 6 Tire	3 Axle Single	4 Axle Single	<5 Axl Double	5 Axle Double	>6 Axl Double	<6 Axl Multi	6 Axle Multi	>6 Axl Multi	Not Classed	Total
Grand Total	9	4770	1881	11	970	18	1	69	2	0	0	0	0	244	7975
Percent	0.1%	59.8%	23.6%	0.1%	12.2%	0.2%	0%	0.9%	0%	0%	0%	0%	0%	3.1%	



Comments:

LOCATION: E Illinois St btwn Main St and Washington St **QC JOB #:** 16302724
SPECIFIC LOCATION: **DIRECTION:** EB
CITY/STATE: Newberg, OR **DATE:** Sep 12 2023

Start Time	Bikes	Cars & Trailers	2 Axle Long	Buses	2 Axle 6 Tire	3 Axle Single	4 Axle Single	<5 Axl Double	5 Axle Double	>6 Axl Double	<6 Axl Multi	6 Axle Multi	>6 Axl Multi	Not Classed	Total
12:00 AM	0	1	0	0	0	0	0	0	0	0	0	0	0	0	1
01:00 AM	0	1	0	0	0	0	0	0	0	0	0	0	0	0	1
02:00 AM	0	0	4	0	0	0	0	0	0	0	0	0	0	0	4
03:00 AM	0	0	0	0	0	0	0	0	0	0	0	0	0	0	0
04:00 AM	0	24	15	0	7	0	0	0	0	0	0	0	0	1	47
05:00 AM	0	19	6	0	9	0	0	0	0	0	0	0	0	1	35
06:00 AM	0	40	25	0	13	0	0	0	0	0	0	0	0	2	80
07:00 AM	0	74	33	0	20	1	0	2	0	0	0	0	0	2	132
08:00 AM	2	64	19	2	15	0	0	1	0	0	0	0	0	7	110
09:00 AM	0	37	13	0	14	0	0	4	0	0	0	0	0	0	68
10:00 AM	0	34	12	0	8	0	0	0	0	0	0	0	0	2	56
11:00 AM	0	45	16	0	6	0	0	4	0	0	0	0	0	0	71
12:00 PM	0	37	14	0	11	0	0	0	0	0	0	0	0	0	62
01:00 PM	0	40	15	0	9	0	0	1	0	0	0	0	0	1	66
02:00 PM	0	48	23	1	2	0	0	1	0	0	0	0	0	0	75
03:00 PM	0	57	30	2	23	0	0	1	0	0	0	0	0	2	115
04:00 PM	0	51	21	0	16	0	0	3	0	0	0	0	0	2	93
05:00 PM	1	55	25	1	11	1	0	0	0	0	0	0	0	1	95
06:00 PM	0	51	20	0	6	0	0	1	0	0	0	0	0	2	80
07:00 PM	0	34	8	0	9	0	0	0	0	0	0	0	0	0	51
08:00 PM	0	19	7	0	4	0	0	0	0	0	0	0	0	2	32
09:00 PM	0	7	5	0	1	0	0	0	0	0	0	0	0	0	13
10:00 PM	0	7	3	0	1	0	0	0	0	0	0	0	0	0	11
11:00 PM	0	5	0	0	0	0	0	0	0	0	0	0	0	0	5
Day Total	3	750	314	6	185	2	0	18	0	0	0	0	0	25	1303
Percent	0.2%	57.6%	24.1%	0.5%	14.2%	0.2%	0%	1.4%	0%	0%	0%	0%	0%	1.9%	
ADT 1303															
AM Peak	8:00 AM	7:00 AM	7:00 AM	8:00 AM	7:00 AM	7:00 AM	12:00 AM	9:00 AM	12:00 AM	12:00 AM	12:00 AM	12:00 AM	12:00 AM	8:00 AM	7:00 AM
Volume	2	74	33	2	20	1	0	4	0	0	0	0	0	7	132
PM Peak	5:00 PM	3:00 PM	3:00 PM	3:00 PM	3:00 PM	5:00 PM	12:00 PM	4:00 PM	12:00 PM	12:00 PM	12:00 PM	12:00 PM	12:00 PM	3:00 PM	3:00 PM
Volume	1	57	30	2	23	1	0	3	0	0	0	0	0	2	115

Comments:

LOCATION: E Illinois St btwn Main St and Washington St **QC JOB #:** 16302724
SPECIFIC LOCATION: **DIRECTION:** EB
CITY/STATE: Newberg, OR **DATE:** Sep 13 2023

Start Time	Bikes	Cars & Trailers	2 Axle Long	Buses	2 Axle 6 Tire	3 Axle Single	4 Axle Single	<5 Axl Double	5 Axle Double	>6 Axl Double	<6 Axl Multi	6 Axle Multi	>6 Axl Multi	Not Classed	Total
12:00 AM	0	3	1	0	0	0	0	0	0	0	0	0	0	0	4
01:00 AM	0	0	1	0	0	0	0	0	0	0	0	0	0	0	1
02:00 AM	0	0	1	0	0	0	0	0	0	0	0	0	0	0	1
03:00 AM	0	0	0	0	0	0	0	0	0	0	0	0	0	0	0
04:00 AM	0	22	14	0	5	0	0	0	0	0	0	0	0	0	41
05:00 AM	0	27	8	0	5	0	0	0	0	0	0	0	0	2	42
06:00 AM	0	29	22	1	9	0	0	0	0	0	0	0	0	0	61
07:00 AM	0	50	19	0	13	0	0	0	0	0	0	0	0	2	84
08:00 AM	1	68	24	1	19	0	0	4	0	0	0	0	0	3	120
09:00 AM	0	58	27	0	13	2	0	2	0	0	0	0	0	1	103
10:00 AM	0	30	10	0	6	0	0	1	0	0	0	0	0	2	49
11:00 AM	0	38	14	1	8	1	0	2	0	0	0	0	0	0	64
12:00 PM	0	39	11	1	6	0	0	1	0	0	0	0	0	3	61
01:00 PM	0	30	15	0	9	0	0	0	0	0	0	0	0	2	56
02:00 PM	1	51	20	1	11	1	0	1	0	0	0	0	0	2	88
03:00 PM	2	49	23	1	16	0	0	0	0	0	0	0	0	6	97
04:00 PM	0	48	26	0	8	0	0	1	0	0	0	0	0	2	85
05:00 PM	0	60	24	0	14	0	0	0	0	0	0	0	0	2	100
06:00 PM	1	45	18	0	13	0	0	1	0	0	0	0	0	3	81
07:00 PM	0	37	12	0	9	0	0	0	0	0	0	0	0	1	59
08:00 PM	0	25	6	0	2	0	0	0	0	0	0	0	0	0	33
09:00 PM	0	21	7	0	0	0	0	0	0	0	0	0	0	0	28
10:00 PM	0	7	2	0	2	0	0	0	0	0	0	0	0	0	11
11:00 PM	0	7	2	0	0	0	0	0	0	0	0	0	0	0	9
Day Total	5	744	307	6	168	4	0	13	0	0	0	0	0	31	1278
Percent	0.4%	58.2%	24%	0.5%	13.1%	0.3%	0%	1%	0%	0%	0%	0%	0%	2.4%	
ADT 1278															
AM Peak	8:00 AM	8:00 AM	9:00 AM	6:00 AM	8:00 AM	9:00 AM	12:00 AM	8:00 AM	12:00 AM	12:00 AM	12:00 AM	12:00 AM	12:00 AM	8:00 AM	8:00 AM
Volume	1	68	27	1	19	2	0	4	0	0	0	0	0	3	120
PM Peak	3:00 PM	5:00 PM	4:00 PM	12:00 PM	3:00 PM	2:00 PM	12:00 PM	12:00 PM	12:00 PM	12:00 PM	12:00 PM	12:00 PM	12:00 PM	3:00 PM	5:00 PM
Volume	2	60	26	1	16	1	0	1	0	0	0	0	0	6	100

Comments:

LOCATION: E Illinois St btwn Main St and Washington St **QC JOB #:** 16302724
SPECIFIC LOCATION: **DIRECTION:** EB
CITY/STATE: Newberg, OR **DATE:** Sep 14 2023

Start Time	Bikes	Cars & Trailers	2 Axle Long	Buses	2 Axle 6 Tire	3 Axle Single	4 Axle Single	<5 Axl Double	5 Axle Double	>6 Axl Double	<6 Axl Multi	6 Axle Multi	>6 Axl Multi	Not Classed	Total
12:00 AM	0	1	1	0	0	0	0	0	0	0	0	0	0	0	2
01:00 AM	0	0	1	0	0	0	0	0	0	0	0	0	0	0	1
02:00 AM	0	0	0	0	0	0	0	0	0	0	0	0	0	0	0
03:00 AM	0	0	3	0	0	0	0	0	0	0	0	0	0	0	3
04:00 AM	0	24	16	0	7	0	0	0	0	0	0	0	0	0	47
05:00 AM	0	23	8	0	5	0	0	0	0	0	0	0	0	2	38
06:00 AM	0	33	26	0	11	0	0	0	0	0	0	0	0	1	71
07:00 AM	1	78	20	0	19	0	1	3	0	0	0	0	0	2	124
08:00 AM	1	54	27	2	16	0	0	5	0	0	0	0	0	3	108
09:00 AM	0	36	15	0	6	1	1	2	0	0	0	0	0	0	61
10:00 AM	0	33	16	0	9	1	0	0	0	0	0	0	0	1	60
11:00 AM	0	34	15	0	8	1	1	0	1	0	0	0	0	2	62
12:00 PM	1	37	17	0	11	0	1	1	0	1	0	0	0	1	70
01:00 PM	1	43	18	0	15	0	0	0	0	0	0	0	0	1	78
02:00 PM	2	50	20	2	7	1	1	1	0	0	0	0	0	1	85
03:00 PM	1	38	25	2	12	0	0	1	0	0	0	0	0	1	80
04:00 PM	0	50	29	0	10	0	0	3	0	0	0	0	0	0	92
05:00 PM	0	53	25	0	11	0	0	0	1	0	0	0	0	2	92
06:00 PM	0	60	22	0	9	0	0	0	0	0	0	0	0	4	95
07:00 PM	0	39	18	0	4	0	0	1	0	0	0	0	0	0	62
08:00 PM	0	36	5	0	2	0	0	0	0	0	0	0	0	3	46
09:00 PM	0	18	2	0	5	0	0	0	0	0	0	0	0	0	25
10:00 PM	0	6	3	0	0	0	0	0	0	0	0	0	0	0	9
11:00 PM	0	5	2	0	0	0	0	0	0	0	0	0	0	0	7
Day Total	7	751	334	6	167	4	5	17	2	1	0	0	0	24	1318
Percent	0.5%	57%	25.3%	0.5%	12.7%	0.3%	0.4%	1.3%	0.2%	0.1%	0%	0%	0%	1.8%	
ADT 1318															
AM Peak Volume	7:00 AM 1	7:00 AM 78	8:00 AM 27	8:00 AM 2	7:00 AM 19	9:00 AM 1	7:00 AM 1	8:00 AM 5	11:00 AM 1	12:00 AM 0	12:00 AM 0	12:00 AM 0	12:00 AM 0	8:00 AM 3	7:00 AM 124
PM Peak Volume	2:00 PM 2	6:00 PM 60	4:00 PM 29	2:00 PM 2	1:00 PM 15	2:00 PM 1	12:00 PM 1	4:00 PM 3	5:00 PM 1	12:00 PM 1	12:00 PM 0	12:00 PM 0	12:00 PM 0	6:00 PM 4	6:00 PM 95

Comments:

Type of report: Tube Count - Vehicle Classification Data

LOCATION: E Illinois St btwn Main St and Washington St **QC JOB #:** 16302724
SPECIFIC LOCATION: **DIRECTION:** EB
CITY/STATE: Newberg, OR **DATE:** Sep 15 2023

Start Time	Bikes	Cars & Trailers	2 Axle Long	Buses	2 Axle 6 Tire	3 Axle Single	4 Axle Single	<5 Axl Double	5 Axle Double	>6 Axl Double	<6 Axl Multi	6 Axle Multi	>6 Axl Multi	Not Classed	Total
12:00 AM	0	4	1	0	0	0	0	0	0	0	0	0	0	0	5
01:00 AM	0	1	0	0	0	0	0	0	0	0	0	0	0	0	1
02:00 AM	0	1	2	0	0	0	0	0	0	0	0	0	0	0	3
03:00 AM	0	2	1	0	0	0	0	0	0	0	0	0	0	0	3
04:00 AM	0	5	3	0	3	0	0	0	0	0	0	0	0	0	11
05:00 AM	0	14	7	0	0	0	0	0	0	0	0	0	0	1	22
06:00 AM	0	37	24	0	12	0	0	0	1	0	0	0	0	2	76
07:00 AM	0	72	26	0	16	0	0	2	0	0	0	0	0	2	118
08:00 AM	1	59	31	1	13	0	0	2	0	0	0	0	0	1	108
09:00 AM	1	40	16	0	14	1	0	1	0	0	0	0	0	3	76
10:00 AM	1	27	17	0	9	0	0	0	0	0	0	0	0	3	57
11:00 AM	0	37	21	2	10	0	0	1	0	0	0	0	0	1	72
12:00 PM	0	31	12	0	8	0	0	1	0	0	0	0	0	0	52
01:00 PM	0	42	22	0	11	1	0	1	0	0	0	0	0	2	79
02:00 PM	0	47	24	2	8	0	1	1	0	0	0	0	0	1	84
03:00 PM	0	59	27	1	12	0	0	0	0	0	0	0	0	2	101
04:00 PM	0	60	17	0	8	0	0	1	0	0	0	0	0	0	86
05:00 PM	0	55	26	0	8	0	0	1	0	0	0	0	0	3	93
06:00 PM	0	42	14	1	13	0	0	0	0	0	0	0	0	3	73
07:00 PM	0	27	8	0	8	0	0	0	0	0	0	0	0	0	43
08:00 PM	0	24	4	0	4	0	0	0	0	0	0	0	0	1	33
09:00 PM	1	18	3	0	5	0	0	0	0	0	0	0	0	0	27
10:00 PM	0	8	7	0	0	0	0	0	0	0	0	0	0	0	15
11:00 PM	0	9	1	0	0	0	0	0	0	0	0	0	0	0	10
Day Total	4	721	314	7	162	2	1	11	1	0	0	0	0	25	1248
Percent	0.3%	57.8%	25.2%	0.6%	13%	0.2%	0.1%	0.9%	0.1%	0%	0%	0%	0%	2%	
ADT 1248															
AM Peak Volume	8:00 AM 1	7:00 AM 72	8:00 AM 31	11:00 AM 2	7:00 AM 16	9:00 AM 1	12:00 AM 0	7:00 AM 2	6:00 AM 1	12:00 AM 0	12:00 AM 0	12:00 AM 0	12:00 AM 0	9:00 AM 3	7:00 AM 118
PM Peak Volume	9:00 PM 1	4:00 PM 60	3:00 PM 27	2:00 PM 2	6:00 PM 13	1:00 PM 1	2:00 PM 1	12:00 PM 1	12:00 PM 0	12:00 PM 0	12:00 PM 0	12:00 PM 0	12:00 PM 0	5:00 PM 3	3:00 PM 101

Comments:

LOCATION: E Illinois St btwn Main St and Washington St **QC JOB #:** 16302724
SPECIFIC LOCATION: **DIRECTION:** EB
CITY/STATE: Newberg, OR **DATE:** Sep 16 2023

Start Time	Bikes	Cars & Trailers	2 Axle Long	Buses	2 Axle 6 Tire	3 Axle Single	4 Axle Single	<5 Axl Double	5 Axle Double	>6 Axl Double	<6 Axl Multi	6 Axle Multi	>6 Axl Multi	Not Classed	Total	
12:00 AM	0	3	1	0	0	0	0	0	0	0	0	0	0	0	4	
01:00 AM	0	0	0	0	1	0	0	0	0	0	0	0	0	0	1	
02:00 AM	0	3	0	0	0	0	0	0	0	0	0	0	0	0	3	
03:00 AM	0	1	1	0	0	0	0	0	0	0	0	0	0	0	2	
04:00 AM	0	4	4	0	0	0	0	0	0	0	0	0	0	0	8	
05:00 AM	0	3	1	0	1	0	0	0	0	0	0	0	0	1	6	
06:00 AM	0	5	4	0	1	1	0	0	0	0	0	0	0	1	12	
07:00 AM	0	20	6	0	1	0	0	1	0	0	0	0	0	0	28	
08:00 AM	0	38	9	0	7	0	0	3	0	0	0	0	0	2	59	
09:00 AM	0	42	22	0	4	0	0	0	0	0	0	0	0	1	69	
10:00 AM	0	71	15	0	8	0	0	0	0	0	0	0	0	0	94	
11:00 AM	2	55	21	0	8	0	0	1	0	0	0	0	0	3	90	
12:00 PM	0	55	23	0	11	0	0	1	1	0	0	0	0	1	92	
01:00 PM	0	43	12	0	9	0	0	0	0	0	0	0	0	3	67	
02:00 PM	0	47	16	1	16	0	0	0	0	0	0	0	0	2	82	
03:00 PM	0	48	10	1	8	0	0	0	0	0	0	0	0	1	68	
04:00 PM	0	43	17	0	7	0	0	0	0	0	0	0	0	1	68	
05:00 PM	0	51	14	0	4	0	0	0	0	0	0	0	0	1	70	
06:00 PM	0	37	19	0	9	0	0	1	0	0	0	0	0	3	69	
07:00 PM	0	25	9	0	4	0	0	0	0	0	0	0	0	0	38	
08:00 PM	1	26	5	0	2	0	0	0	0	0	0	0	0	0	34	
09:00 PM	0	15	5	0	2	0	0	0	0	0	0	0	0	0	22	
10:00 PM	0	16	1	0	0	0	0	0	0	0	0	0	0	0	17	
11:00 PM	0	12	3	0	1	0	0	0	0	0	0	0	0	1	17	
Day Total	3	663	218	2	104	1	0	7	1	0	0	0	0	21	1020	
Percent	0.3%	65%	21.4%	0.2%	10.2%	0.1%	0%	0.7%	0.1%	0%	0%	0%	0%	2.1%		
ADT 1020																
AM Peak	11:00 AM	10:00 AM	9:00 AM	12:00 AM	10:00 AM	6:00 AM	12:00 AM	8:00 AM	12:00 AM	12:00 AM	12:00 AM	12:00 AM	12:00 AM	12:00 AM	11:00 AM	10:00 AM
Volume	2	71	22	0	8	1	0	3	0	0	0	0	0	3	94	
PM Peak	8:00 PM	12:00 PM	12:00 PM	2:00 PM	2:00 PM	12:00 PM	12:00 PM	12:00 PM	12:00 PM	12:00 PM	12:00 PM	12:00 PM	12:00 PM	12:00 PM	1:00 PM	12:00 PM
Volume	1	55	23	1	16	0	0	1	1	0	0	0	0	3	92	

Comments:

LOCATION: E Illinois St btwn Main St and Washington St **QC JOB #:** 16302724
SPECIFIC LOCATION: **DIRECTION:** EB
CITY/STATE: Newberg, OR **DATE:** Sep 17 2023

Start Time	Bikes	Cars & Trailers	2 Axle Long	Buses	2 Axle 6 Tire	3 Axle Single	4 Axle Single	<5 Axl Double	5 Axle Double	>6 Axl Double	<6 Axl Multi	6 Axle Multi	>6 Axl Multi	Not Classed	Total
12:00 AM	0	4	3	0	2	0	0	0	0	0	0	0	0	1	10
01:00 AM	0	6	0	0	0	0	0	0	0	0	0	0	0	0	6
02:00 AM	0	2	1	0	0	0	0	0	0	0	0	0	0	0	3
03:00 AM	0	1	0	0	0	0	0	0	0	0	0	0	0	0	1
04:00 AM	0	5	4	0	0	0	0	0	0	0	0	0	0	0	9
05:00 AM	0	6	1	0	1	0	0	0	0	0	0	0	0	0	8
06:00 AM	0	9	3	0	1	0	0	0	0	0	0	0	0	0	13
07:00 AM	0	21	2	0	2	0	0	1	0	0	0	0	0	1	27
08:00 AM	0	25	10	0	2	0	0	1	0	0	0	0	0	0	38
09:00 AM	0	48	11	0	3	0	0	2	0	0	0	0	0	3	67
10:00 AM	1	42	15	0	5	0	0	0	0	0	0	0	0	3	66
11:00 AM	0	41	19	0	11	0	0	0	0	0	0	0	0	3	74
12:00 PM	0	60	16	1	9	0	0	3	0	0	0	0	0	4	93
01:00 PM	1	56	25	0	5	0	0	0	0	0	0	0	0	4	91
02:00 PM	1	41	18	1	6	0	0	1	0	0	0	0	0	2	70
03:00 PM	0	43	16	0	8	0	0	0	0	0	0	0	0	4	71
04:00 PM	0	45	8	0	7	0	0	1	0	0	0	0	0	1	62
05:00 PM	0	49	16	0	15	0	0	0	0	0	0	0	0	1	81
06:00 PM	0	38	15	0	3	0	0	0	0	0	0	0	0	0	56
07:00 PM	0	23	9	0	5	0	0	0	0	0	0	0	0	1	38
08:00 PM	0	21	9	0	1	0	0	0	0	0	0	0	0	0	31
09:00 PM	0	16	3	0	2	0	0	0	0	0	0	0	0	0	21
10:00 PM	0	4	1	0	1	0	0	0	0	0	0	0	0	0	6
11:00 PM	0	6	0	0	1	0	0	0	0	0	0	0	0	0	7
Day Total	3	612	205	2	90	0	0	9	0	0	0	0	0	28	949
Percent	0.3%	64.5%	21.6%	0.2%	9.5%	0%	0%	0.9%	0%	0%	0%	0%	0%	3%	
ADT 949															
AM Peak	10:00 AM	9:00 AM	11:00 AM	12:00 AM	11:00 AM	12:00 AM	12:00 AM	9:00 AM	12:00 AM	12:00 AM	12:00 AM	12:00 AM	12:00 AM	9:00 AM	11:00 AM
Volume	1	48	19	0	11	0	0	2	0	0	0	0	0	3	74
PM Peak	1:00 PM	12:00 PM	1:00 PM	12:00 PM	5:00 PM	12:00 PM	12:00 PM	12:00 PM	12:00 PM	12:00 PM	12:00 PM	12:00 PM	12:00 PM	12:00 PM	12:00 PM
Volume	1	60	25	1	15	0	0	3	0	0	0	0	0	4	93

Comments:

LOCATION: E Illinois St btwn Main St and Washington St **QC JOB #:** 16302724
SPECIFIC LOCATION: **DIRECTION:** EB
CITY/STATE: Newberg, OR **DATE:** Sep 18 2023

Start Time	Bikes	Cars & Trailers	2 Axle Long	Buses	2 Axle 6 Tire	3 Axle Single	4 Axle Single	<5 Axl Double	5 Axle Double	>6 Axl Double	<6 Axl Multi	6 Axle Multi	>6 Axl Multi	Not Classed	Total
12:00 AM	0	3	3	0	0	0	0	0	0	0	0	0	0	0	6
01:00 AM	0	1	1	0	0	0	0	0	0	0	0	0	0	0	2
02:00 AM	0	1	1	0	0	0	0	0	0	0	0	0	0	0	2
03:00 AM	0	0	1	0	0	0	0	0	0	0	0	0	0	0	1
04:00 AM	0	27	11	0	8	0	0	0	0	0	0	0	0	1	47
05:00 AM	0	25	9	0	3	0	0	0	0	0	0	0	0	0	37
06:00 AM	0	33	21	0	12	0	0	0	0	0	0	0	0	0	66
07:00 AM	0	86	24	0	21	0	0	1	0	0	0	0	0	1	133
08:00 AM	0	69	23	2	11	0	0	2	0	0	0	0	0	3	110
09:00 AM	0	35	16	1	10	0	1	1	0	0	0	0	0	0	64
10:00 AM	0	43	14	2	3	0	1	2	0	0	0	0	0	0	65
11:00 AM	1	32	13	0	11	2	1	1	0	0	0	0	0	4	65
12:00 PM	0	41	13	1	12	0	1	0	0	0	0	0	0	3	71
01:00 PM	0	48	11	1	9	0	1	1	0	0	0	0	0	1	72
02:00 PM	0	50	22	1	7	1	0	2	0	0	0	0	0	0	83
03:00 PM	2	53	19	1	10	2	0	1	0	0	0	0	0	0	88
04:00 PM	1	62	19	0	11	0	0	0	0	0	0	0	0	3	96
05:00 PM	1	49	17	0	8	0	0	0	0	0	0	0	0	0	75
06:00 PM	0	41	25	0	10	0	0	0	0	0	0	0	0	0	76
07:00 PM	0	29	11	0	4	0	0	0	0	0	0	0	0	3	47
08:00 PM	0	20	5	0	1	0	0	0	0	0	0	0	0	1	27
09:00 PM	0	14	5	0	0	0	0	0	0	0	0	0	0	1	20
10:00 PM	0	6	1	0	1	0	0	0	0	0	0	0	0	3	11
11:00 PM	0	2	0	0	0	0	0	0	0	0	0	0	0	0	2
Day Total	5	770	285	9	152	5	5	11	0	0	0	0	0	24	1266
Percent	0.4%	60.8%	22.5%	0.7%	12%	0.4%	0.4%	0.9%	0%	0%	0%	0%	0%	1.9%	
ADT 1266															
AM Peak	11:00 AM	7:00 AM	7:00 AM	8:00 AM	7:00 AM	11:00 AM	9:00 AM	8:00 AM	12:00 AM	12:00 AM	12:00 AM	12:00 AM	12:00 AM	11:00 AM	7:00 AM
Volume	1	86	24	2	21	2	1	2	0	0	0	0	0	4	133
PM Peak	3:00 PM	4:00 PM	6:00 PM	12:00 PM	12:00 PM	3:00 PM	12:00 PM	2:00 PM	12:00 PM	12:00 PM	12:00 PM	12:00 PM	12:00 PM	12:00 PM	4:00 PM
Volume	2	62	25	1	12	2	1	2	0	0	0	0	0	3	96

Comments:

LOCATION: E Illinois St btwn Main St and Washington St **QC JOB #:** 16302724
SPECIFIC LOCATION: **DIRECTION:** EB
CITY/STATE: Newberg, OR **DATE:** Sep 12 2023 - Sep 18 2023

Start Time	Bikes	Cars & Trailers	2 Axle Long	Buses	2 Axle 6 Tire	3 Axle Single	4 Axle Single	<5 Axl Double	5 Axle Double	>6 Axl Double	<6 Axl Multi	6 Axle Multi	>6 Axl Multi	Not Classed	Total
Grand Total	30	5011	1977	38	1028	18	11	86	4	1	0	0	0	178	8382
Percent	0.4%	59.8%	23.6%	0.5%	12.3%	0.2%	0.1%	1%	0%	0%	0%	0%	0%	2.1%	
ADT 1197															

Comments:

LOCATION: HWY 240 btwn Illinois St and North St **QC JOB #:** 16302725
SPECIFIC LOCATION: **DIRECTION:** SB
CITY/STATE: Newberg, OR **DATE:** Sep 12 2023

Start Time	Bikes	Cars & Trailers	2 Axle Long	Buses	2 Axle 6 Tire	3 Axle Single	4 Axle Single	<5 Axl Double	5 Axle Double	>6 Axl Double	<6 Axl Multi	6 Axle Multi	>6 Axl Multi	Not Classed	Total
12:00 AM	0	5	2	0	1	0	0	0	0	0	0	0	0	0	8
01:00 AM	0	7	1	0	1	0	0	0	0	0	0	0	0	0	9
02:00 AM	0	3	1	0	1	0	0	0	0	0	0	0	0	0	5
03:00 AM	0	7	9	0	4	0	0	1	1	0	0	0	0	1	23
04:00 AM	0	28	24	0	18	0	1	0	0	0	0	0	0	0	71
05:00 AM	2	77	37	3	47	2	0	2	0	5	0	0	1	3	179
06:00 AM	9	156	64	2	83	5	1	11	1	3	0	0	1	21	357
07:00 AM	7	183	99	5	75	2	4	9	1	2	0	0	1	36	424
08:00 AM	11	147	106	3	66	4	2	15	1	4	0	0	3	30	392
09:00 AM	7	149	95	3	67	4	3	17	0	2	0	0	0	23	370
10:00 AM	5	140	86	7	56	3	1	15	3	6	0	1	0	23	346
11:00 AM	6	151	73	3	56	4	4	22	4	4	0	0	0	19	346
12:00 PM	6	112	57	3	61	5	2	10	4	2	0	0	0	34	296
01:00 PM	7	145	53	3	48	6	0	14	3	1	0	0	0	27	307
02:00 PM	7	133	87	6	60	3	2	25	0	0	0	0	0	35	358
03:00 PM	20	152	80	7	64	8	2	19	2	0	0	1	0	54	409
04:00 PM	24	126	69	8	60	5	1	22	1	3	1	0	0	57	377
05:00 PM	18	140	74	1	53	7	1	21	0	0	0	0	0	59	374
06:00 PM	10	152	74	0	33	1	0	13	0	1	0	0	0	37	321
07:00 PM	9	93	54	0	24	2	0	4	1	0	0	0	1	24	212
08:00 PM	4	74	35	0	26	0	0	5	0	0	0	0	0	16	160
09:00 PM	2	49	16	1	6	0	2	2	0	0	0	0	0	4	82
10:00 PM	0	23	4	0	4	0	0	0	0	0	0	0	0	1	32
11:00 PM	1	8	1	0	1	0	0	0	0	0	0	0	0	0	11
Day Total	155	2260	1201	55	915	61	26	227	22	33	1	2	7	504	5469
Percent	2.8%	41.3%	22%	1%	16.7%	1.1%	0.5%	4.2%	0.4%	0.6%	0%	0%	0.1%	9.2%	
ADT 5469															
AM Peak	8:00 AM	7:00 AM	8:00 AM	10:00 AM	6:00 AM	6:00 AM	7:00 AM	11:00 AM	11:00 AM	10:00 AM	12:00 AM	10:00 AM	8:00 AM	7:00 AM	7:00 AM
Volume	11	183	106	7	83	5	4	22	4	6	0	1	3	36	424
PM Peak	4:00 PM	3:00 PM	2:00 PM	4:00 PM	3:00 PM	3:00 PM	12:00 PM	2:00 PM	12:00 PM	4:00 PM	4:00 PM	3:00 PM	7:00 PM	5:00 PM	3:00 PM
Volume	24	152	87	8	64	8	2	25	4	3	1	1	1	59	409

Comments:

LOCATION: HWY 240 btwn Illinois St and North St

QC JOB #: 16302725

SPECIFIC LOCATION:

DIRECTION: SB

CITY/STATE: Newberg, OR

DATE: Sep 13 2023

Start Time	Bikes	Cars & Trailers	2 Axle Long	Buses	2 Axle 6 Tire	3 Axle Single	4 Axle Single	<5 Axl Double	5 Axle Double	>6 Axl Double	<6 Axl Multi	6 Axle Multi	>6 Axl Multi	Not Classed	Total
12:00 AM	0	8	2	0	1	0	0	0	0	0	0	0	0	0	11
01:00 AM	0	5	2	0	0	0	0	0	0	0	0	0	0	0	7
02:00 AM	0	6	2	0	2	0	0	0	0	1	0	0	0	0	11
03:00 AM	0	9	7	1	5	0	0	0	0	0	0	0	0	0	22
04:00 AM	1	39	14	0	15	0	0	1	0	0	0	0	0	3	73
05:00 AM	5	79	34	5	41	1	0	1	1	2	0	0	0	9	178
06:00 AM	8	162	54	4	68	3	2	17	1	4	0	0	0	26	349
07:00 AM	11	177	108	5	85	6	2	16	2	2	0	0	1	20	435
08:00 AM	10	182	102	7	68	5	3	14	2	1	0	0	0	38	432
09:00 AM	7	146	86	4	58	1	0	17	2	0	0	0	0	20	341
10:00 AM	5	161	80	3	50	5	2	15	4	3	0	0	1	27	356
11:00 AM	9	152	95	4	50	7	3	12	2	2	0	0	1	36	373
12:00 PM	7	132	61	2	61	5	1	13	1	3	0	0	0	28	314
01:00 PM	7	155	62	3	53	2	1	20	2	2	0	0	0	29	336
02:00 PM	20	135	87	5	62	4	2	20	0	0	0	0	0	40	375
03:00 PM	19	181	115	8	71	6	6	29	2	0	0	0	0	62	499
04:00 PM	16	141	67	3	56	6	3	24	1	1	0	0	0	62	380
05:00 PM	18	164	84	1	56	4	2	15	2	0	0	0	0	61	407
06:00 PM	15	170	62	0	39	0	0	12	3	0	0	0	0	40	341
07:00 PM	4	90	35	0	35	0	1	4	1	0	0	0	0	21	191
08:00 PM	3	80	43	1	10	0	0	0	0	0	0	0	0	4	141
09:00 PM	0	49	16	0	7	0	0	0	1	1	0	0	0	4	78
10:00 PM	0	29	8	0	4	0	0	1	0	0	0	0	0	1	43
11:00 PM	0	9	4	0	5	0	0	0	0	0	0	0	0	0	18
Day Total	165	2461	1230	56	902	55	28	231	27	22	0	0	3	531	5711
Percent	2.9%	43.1%	21.5%	1%	15.8%	1%	0.5%	4%	0.5%	0.4%	0%	0%	0.1%	9.3%	
ADT 5711															
AM Peak	7:00 AM	8:00 AM	7:00 AM	8:00 AM	7:00 AM	11:00 AM	8:00 AM	6:00 AM	10:00 AM	6:00 AM	12:00 AM	12:00 AM	7:00 AM	8:00 AM	7:00 AM
Volume	11	182	108	7	85	7	3	17	4	4	0	0	1	38	435
PM Peak	2:00 PM	3:00 PM	3:00 PM	3:00 PM	3:00 PM	3:00 PM	3:00 PM	3:00 PM	6:00 PM	12:00 PM	12:00 PM	12:00 PM	12:00 PM	3:00 PM	3:00 PM
Volume	20	181	115	8	71	6	6	29	3	3	0	0	0	62	499

Comments:

LOCATION: HWY 240 btwn Illinois St and North St

QC JOB #: 16302725

SPECIFIC LOCATION:

DIRECTION: SB

CITY/STATE: Newberg, OR

DATE: Sep 14 2023

Start Time	Bikes	Cars & Trailers	2 Axle Long	Buses	2 Axle 6 Tire	3 Axle Single	4 Axle Single	<5 Axl Double	5 Axle Double	>6 Axl Double	<6 Axl Multi	6 Axle Multi	>6 Axl Multi	Not Classed	Total
12:00 AM	0	6	0	0	1	0	0	0	0	0	0	0	1	1	9
01:00 AM	0	5	2	0	1	0	0	0	0	0	0	0	0	0	8
02:00 AM	0	10	2	0	2	0	0	0	0	0	0	0	0	0	14
03:00 AM	0	9	6	0	5	0	0	2	1	0	0	0	0	2	25
04:00 AM	0	33	14	0	17	0	0	1	0	0	0	0	0	0	65
05:00 AM	3	78	36	3	47	0	0	5	0	4	0	0	1	6	183
06:00 AM	13	148	56	1	57	3	1	12	2	1	0	0	1	35	330
07:00 AM	12	213	102	6	59	7	3	10	0	2	0	0	0	40	454
08:00 AM	9	162	87	4	69	6	0	18	3	1	0	0	1	42	402
09:00 AM	5	148	70	4	52	3	2	14	0	1	0	0	1	23	323
10:00 AM	5	169	78	2	65	6	4	20	7	2	0	0	0	38	396
11:00 AM	8	175	73	6	52	3	1	17	7	2	0	1	1	27	373
12:00 PM	15	162	68	6	62	3	4	16	2	4	0	0	0	38	380
01:00 PM	13	150	69	6	49	8	2	19	7	2	0	0	0	37	362
02:00 PM	12	148	77	11	50	7	2	22	3	2	0	0	1	35	370
03:00 PM	16	195	91	7	67	5	3	16	1	1	0	0	1	47	450
04:00 PM	20	147	66	2	50	2	1	16	5	0	0	0	0	61	370
05:00 PM	17	161	61	3	52	4	2	21	2	0	0	0	0	56	379
06:00 PM	9	139	68	2	41	3	2	13	0	0	0	0	0	35	312
07:00 PM	7	117	56	0	27	2	0	12	1	0	0	0	0	19	241
08:00 PM	4	83	28	0	25	1	2	2	0	0	0	0	0	8	153
09:00 PM	1	49	17	1	5	0	0	1	0	0	0	0	0	0	74
10:00 PM	0	34	12	0	8	0	0	0	0	0	0	0	0	3	57
11:00 PM	0	10	6	0	1	0	0	0	0	0	0	0	0	0	17
Day Total	169	2551	1145	64	864	63	29	237	41	22	0	1	8	553	5747
Percent	2.9%	44.4%	19.9%	1.1%	15%	1.1%	0.5%	4.1%	0.7%	0.4%	0%	0%	0.1%	9.6%	
ADT 5747															
AM Peak	6:00 AM	7:00 AM	7:00 AM	7:00 AM	8:00 AM	7:00 AM	10:00 AM	10:00 AM	10:00 AM	5:00 AM	12:00 AM	11:00 AM	12:00 AM	8:00 AM	7:00 AM
Volume	13	213	102	6	69	7	4	20	7	4	0	1	1	42	454
PM Peak	4:00 PM	3:00 PM	3:00 PM	2:00 PM	3:00 PM	1:00 PM	12:00 PM	2:00 PM	1:00 PM	12:00 PM	12:00 PM	12:00 PM	2:00 PM	4:00 PM	3:00 PM
Volume	20	195	91	11	67	8	4	22	7	4	0	0	1	61	450

Comments:

LOCATION: HWY 240 btwn Illinois St and North St **QC JOB #:** 16302725
SPECIFIC LOCATION: **DIRECTION:** SB
CITY/STATE: Newberg, OR **DATE:** Sep 15 2023

Start Time	Bikes	Cars & Trailers	2 Axle Long	Buses	2 Axle 6 Tire	3 Axle Single	4 Axle Single	<5 Axl Double	5 Axle Double	>6 Axl Double	<6 Axl Multi	6 Axle Multi	>6 Axl Multi	Not Classed	Total
12:00 AM	0	4	3	0	0	0	0	0	0	0	0	0	0	0	7
01:00 AM	0	5	1	0	3	0	0	0	0	0	0	0	0	0	9
02:00 AM	0	7	0	0	1	0	0	0	0	0	0	0	0	0	8
03:00 AM	0	6	4	1	1	0	0	2	0	1	0	0	0	1	16
04:00 AM	0	26	9	0	17	0	0	1	0	0	0	0	0	0	53
05:00 AM	1	66	30	2	28	3	0	5	0	1	0	0	1	8	145
06:00 AM	4	129	60	5	58	3	1	10	3	3	0	0	0	22	298
07:00 AM	6	202	89	5	67	2	1	11	4	3	0	0	2	32	424
08:00 AM	13	175	88	1	72	4	0	9	3	2	0	0	1	44	412
09:00 AM	12	167	74	4	55	4	2	15	3	2	0	0	1	28	367
10:00 AM	14	167	73	3	58	2	1	14	1	2	0	0	2	27	364
11:00 AM	19	148	80	2	69	6	2	16	7	5	0	0	0	31	385
12:00 PM	5	150	69	5	60	6	4	24	3	2	0	0	0	42	370
01:00 PM	10	125	66	5	48	5	1	25	5	1	0	1	0	46	338
02:00 PM	19	149	83	4	64	0	4	16	6	1	0	0	0	34	380
03:00 PM	22	151	85	3	39	7	4	32	0	1	0	0	0	45	389
04:00 PM	23	134	71	10	59	4	1	18	2	1	0	0	0	54	377
05:00 PM	21	158	57	1	53	3	5	17	1	0	0	0	1	48	365
06:00 PM	12	154	64	3	42	1	3	15	0	0	0	0	0	22	316
07:00 PM	5	140	37	1	35	2	2	6	2	0	0	0	0	18	248
08:00 PM	5	105	39	0	16	0	0	4	0	0	0	0	0	4	173
09:00 PM	3	75	31	0	11	0	0	0	0	0	0	0	0	7	127
10:00 PM	0	54	20	0	14	0	0	3	0	0	0	0	0	3	94
11:00 PM	0	22	10	0	2	0	0	0	0	0	0	0	0	0	34
Day Total	194	2519	1143	55	872	52	31	243	40	25	0	1	8	516	5699
Percent	3.4%	44.2%	20.1%	1%	15.3%	0.9%	0.5%	4.3%	0.7%	0.4%	0%	0%	0.1%	9.1%	
ADT 5699															
AM Peak	11:00 AM	7:00 AM	7:00 AM	6:00 AM	8:00 AM	11:00 AM	9:00 AM	11:00 AM	11:00 AM	11:00 AM	12:00 AM	12:00 AM	7:00 AM	8:00 AM	7:00 AM
Volume	19	202	89	5	72	6	2	16	7	5	0	0	2	44	424
PM Peak	4:00 PM	5:00 PM	3:00 PM	4:00 PM	2:00 PM	3:00 PM	5:00 PM	3:00 PM	2:00 PM	12:00 PM	12:00 PM	1:00 PM	5:00 PM	4:00 PM	3:00 PM
Volume	23	158	85	10	64	7	5	32	6	2	0	1	1	54	389

Comments:

LOCATION: HWY 240 btwn Illinois St and North St **QC JOB #:** 16302725
SPECIFIC LOCATION: **DIRECTION:** SB
CITY/STATE: Newberg, OR **DATE:** Sep 16 2023

Start Time	Bikes	Cars & Trailers	2 Axle Long	Buses	2 Axle 6 Tire	3 Axle Single	4 Axle Single	<5 Axl Double	5 Axle Double	>6 Axl Double	<6 Axl Multi	6 Axle Multi	>6 Axl Multi	Not Classed	Total
12:00 AM	0	15	2	1	3	0	0	1	0	0	0	0	0	0	22
01:00 AM	0	10	6	0	1	0	0	0	0	0	0	0	0	0	17
02:00 AM	0	6	1	0	2	0	0	0	0	0	0	0	0	0	9
03:00 AM	0	8	7	0	1	0	0	0	0	0	0	0	0	0	16
04:00 AM	0	14	2	0	4	0	0	1	0	0	0	0	0	1	22
05:00 AM	1	20	9	1	7	0	0	6	0	0	0	0	0	3	47
06:00 AM	4	45	21	0	14	0	0	6	1	0	0	0	0	7	98
07:00 AM	4	101	38	2	37	1	1	7	0	0	0	0	0	8	199
08:00 AM	5	119	59	0	36	2	2	15	0	0	0	0	0	11	249
09:00 AM	7	193	75	1	39	5	2	16	2	0	0	0	0	31	371
10:00 AM	14	192	102	1	54	1	1	16	0	1	0	0	0	39	421
11:00 AM	17	237	117	4	46	7	3	27	1	0	0	0	0	49	508
12:00 PM	13	220	114	2	57	3	1	18	2	0	0	0	0	45	475
01:00 PM	12	170	93	0	54	3	1	26	2	0	0	1	0	49	411
02:00 PM	14	181	79	0	45	3	3	16	0	0	0	0	0	46	387
03:00 PM	7	190	76	3	56	2	0	15	0	0	0	0	0	40	389
04:00 PM	10	207	68	0	43	2	3	13	0	1	0	0	0	28	375
05:00 PM	11	197	110	3	39	2	2	24	1	1	0	0	0	43	433
06:00 PM	8	144	56	0	35	0	0	12	0	0	0	0	0	36	291
07:00 PM	5	132	46	0	30	0	0	12	0	0	0	0	0	16	241
08:00 PM	3	147	47	0	20	0	0	4	0	0	0	0	0	19	240
09:00 PM	2	122	41	2	18	0	1	3	0	0	0	0	0	8	197
10:00 PM	1	55	21	0	8	0	0	1	0	0	0	0	0	4	90
11:00 PM	0	43	13	0	2	0	0	0	0	0	0	0	0	1	59
Day Total	138	2768	1203	20	651	31	20	239	9	3	0	1	0	484	5567
Percent	2.5%	49.7%	21.6%	0.4%	11.7%	0.6%	0.4%	4.3%	0.2%	0.1%	0%	0%	0%	8.7%	
ADT 5567															
AM Peak	11:00 AM	11:00 AM	11:00 AM	11:00 AM	10:00 AM	11:00 AM	11:00 AM	11:00 AM	9:00 AM	10:00 AM	12:00 AM	12:00 AM	12:00 AM	11:00 AM	11:00 AM
Volume	17	237	117	4	54	7	3	27	2	1	0	0	0	49	508
PM Peak	2:00 PM	12:00 PM	12:00 PM	3:00 PM	12:00 PM	12:00 PM	2:00 PM	1:00 PM	12:00 PM	4:00 PM	12:00 PM	1:00 PM	12:00 PM	1:00 PM	12:00 PM
Volume	14	220	114	3	57	3	3	26	2	1	0	1	0	49	475

Comments:

LOCATION: HWY 240 btwn Illinois St and North St **QC JOB #:** 16302725
SPECIFIC LOCATION: **DIRECTION:** SB
CITY/STATE: Newberg, OR **DATE:** Sep 17 2023

Start Time	Bikes	Cars & Trailers	2 Axle Long	Buses	2 Axle 6 Tire	3 Axle Single	4 Axle Single	<5 Axl Double	5 Axle Double	>6 Axl Double	<6 Axl Multi	6 Axle Multi	>6 Axl Multi	Not Classed	Total
12:00 AM	0	21	4	1	4	0	0	0	0	0	0	0	0	1	31
01:00 AM	0	11	2	0	0	0	0	0	0	0	0	0	0	0	13
02:00 AM	0	4	2	0	2	0	0	0	0	0	0	0	0	0	8
03:00 AM	0	9	2	0	2	0	0	0	0	0	0	0	0	0	13
04:00 AM	1	8	6	0	2	0	0	2	0	0	0	0	0	0	19
05:00 AM	0	20	9	0	6	0	0	1	0	0	0	0	0	1	37
06:00 AM	0	32	12	2	13	0	0	1	1	0	0	0	0	2	63
07:00 AM	2	74	41	0	25	0	0	3	0	0	0	0	0	7	152
08:00 AM	2	113	35	1	26	1	0	4	1	0	0	0	0	4	187
09:00 AM	7	186	81	0	36	0	2	8	1	0	0	0	0	29	350
10:00 AM	11	182	63	1	40	3	1	16	0	0	0	0	0	32	349
11:00 AM	9	224	89	2	53	2	5	24	1	0	0	0	0	36	445
12:00 PM	14	171	92	1	33	4	2	18	0	0	0	0	0	46	381
01:00 PM	18	207	66	0	43	2	2	18	2	0	0	1	0	47	406
02:00 PM	12	183	71	1	50	0	2	20	1	0	0	0	0	42	382
03:00 PM	9	193	65	0	46	0	3	11	1	0	0	0	0	34	362
04:00 PM	7	191	72	0	33	3	2	16	0	0	0	0	0	38	362
05:00 PM	17	189	84	3	40	3	4	16	0	0	0	0	0	33	389
06:00 PM	4	148	51	0	26	0	0	3	0	1	0	0	0	23	256
07:00 PM	10	111	54	2	27	2	0	4	1	0	0	0	0	14	225
08:00 PM	4	89	34	2	20	0	0	4	0	0	0	0	0	8	161
09:00 PM	2	50	17	0	11	0	0	2	0	0	0	0	0	3	85
10:00 PM	0	28	9	1	3	0	0	1	0	0	0	0	0	0	42
11:00 PM	0	16	5	0	3	0	1	0	0	0	0	0	0	0	25
Day Total	129	2460	966	17	544	20	24	172	9	1	0	1	0	400	4743
Percent	2.7%	51.9%	20.4%	0.4%	11.5%	0.4%	0.5%	3.6%	0.2%	0%	0%	0%	0%	8.4%	
ADT 4743															
AM Peak	10:00 AM	11:00 AM	11:00 AM	6:00 AM	11:00 AM	10:00 AM	11:00 AM	11:00 AM	6:00 AM	12:00 AM	12:00 AM	12:00 AM	12:00 AM	11:00 AM	11:00 AM
Volume	11	224	89	2	53	3	5	24	1	0	0	0	0	36	445
PM Peak	1:00 PM	1:00 PM	12:00 PM	5:00 PM	2:00 PM	12:00 PM	5:00 PM	2:00 PM	1:00 PM	6:00 PM	12:00 PM	1:00 PM	12:00 PM	1:00 PM	1:00 PM
Volume	18	207	92	3	50	4	4	20	2	1	0	1	0	47	406

Comments:

LOCATION: HWY 240 btwn Illinois St and North St **QC JOB #:** 16302725
SPECIFIC LOCATION: **DIRECTION:** SB
CITY/STATE: Newberg, OR **DATE:** Sep 18 2023

Start Time	Bikes	Cars & Trailers	2 Axle Long	Buses	2 Axle 6 Tire	3 Axle Single	4 Axle Single	<5 Axl Double	5 Axle Double	>6 Axl Double	<6 Axl Multi	6 Axle Multi	>6 Axl Multi	Not Classed	Total
12:00 AM	0	8	3	1	1	0	0	0	0	0	0	0	0	0	13
01:00 AM	0	3	1	0	3	0	0	1	0	0	0	0	0	1	9
02:00 AM	0	3	2	0	0	0	0	0	0	0	0	0	0	0	5
03:00 AM	0	8	7	0	4	0	0	0	0	0	0	0	0	0	19
04:00 AM	2	42	17	1	18	0	0	0	1	1	0	0	0	3	85
05:00 AM	1	83	23	2	44	1	0	4	0	2	0	0	1	6	167
06:00 AM	8	160	65	2	63	2	3	18	4	4	0	0	0	15	344
07:00 AM	11	173	102	6	61	6	1	17	4	3	0	0	0	25	409
08:00 AM	5	173	66	6	67	6	1	20	2	1	0	0	0	34	381
09:00 AM	8	160	87	9	70	3	0	15	2	0	0	0	2	27	383
10:00 AM	6	150	61	2	56	6	5	18	3	1	0	0	0	29	337
11:00 AM	14	169	83	10	62	4	1	15	5	3	0	1	2	28	397
12:00 PM	8	143	66	5	55	2	4	12	4	2	0	0	1	39	341
01:00 PM	13	125	62	5	44	7	2	19	8	1	0	0	1	31	318
02:00 PM	13	151	69	2	54	4	1	16	1	1	0	0	0	28	340
03:00 PM	21	174	92	7	80	10	1	22	6	0	0	0	1	49	463
04:00 PM	21	145	62	2	52	3	2	18	0	0	0	0	0	69	374
05:00 PM	13	127	86	0	52	3	1	19	3	0	0	0	0	47	351
06:00 PM	10	146	56	0	41	2	0	12	2	0	0	0	0	24	293
07:00 PM	4	96	43	0	25	0	3	7	0	0	0	0	1	15	194
08:00 PM	2	70	32	0	25	3	1	7	0	0	0	0	0	7	147
09:00 PM	2	69	19	0	7	0	0	0	0	0	0	0	0	2	99
10:00 PM	0	28	15	0	7	0	0	0	0	0	0	0	0	0	50
11:00 PM	0	10	5	0	3	0	0	1	0	0	0	0	0	0	19
Day Total	162	2416	1124	60	894	62	26	241	45	19	0	1	9	479	5538
Percent	2.9%	43.6%	20.3%	1.1%	16.1%	1.1%	0.5%	4.4%	0.8%	0.3%	0%	0%	0.2%	8.6%	
ADT 5538															
AM Peak	11:00 AM	7:00 AM	7:00 AM	11:00 AM	9:00 AM	7:00 AM	10:00 AM	8:00 AM	11:00 AM	6:00 AM	12:00 AM	11:00 AM	9:00 AM	8:00 AM	7:00 AM
Volume	14	173	102	10	70	6	5	20	5	4	0	1	2	34	409
PM Peak	3:00 PM	3:00 PM	3:00 PM	3:00 PM	3:00 PM	3:00 PM	12:00 PM	3:00 PM	1:00 PM	12:00 PM	12:00 PM	12:00 PM	12:00 PM	4:00 PM	3:00 PM
Volume	21	174	92	7	80	10	4	22	8	2	0	0	1	69	463

Comments:

LOCATION: HWY 240 btwn Illinois St and North St **QC JOB #:** 16302725
SPECIFIC LOCATION: **DIRECTION:** SB
CITY/STATE: Newberg, OR **DATE:** Sep 12 2023 - Sep 18 2023

Start Time	Bikes	Cars & Trailers	2 Axle Long	Buses	2 Axle 6 Tire	3 Axle Single	4 Axle Single	<5 Axl Double	5 Axle Double	>6 Axl Double	<6 Axl Multi	6 Axle Multi	>6 Axl Multi	Not Classed	Total
Grand Total	1112	17435	8012	327	5642	344	184	1590	193	125	1	7	35	3467	38474
Percent	2.9%	45.3%	20.8%	0.8%	14.7%	0.9%	0.5%	4.1%	0.5%	0.3%	0%	0%	0.1%	9%	



Comments:

LOCATION: HWY 240 btwn Illinois St and North St **QC JOB #:** 16302725
SPECIFIC LOCATION: **DIRECTION:** NB
CITY/STATE: Newberg, OR **DATE:** Sep 12 2023

Start Time	Bikes	Cars & Trailers	2 Axle Long	Buses	2 Axle 6 Tire	3 Axle Single	4 Axle Single	<5 Axl Double	5 Axle Double	>6 Axl Double	<6 Axl Multi	6 Axle Multi	>6 Axl Multi	Not Classed	Total
12:00 AM	0	6	2	0	0	0	0	0	1	0	0	0	0	0	9
01:00 AM	0	8	1	0	1	1	0	0	0	0	0	0	0	0	11
02:00 AM	0	9	2	0	2	3	0	0	0	0	0	0	0	0	16
03:00 AM	0	7	2	0	2	2	0	0	0	0	0	0	0	0	13
04:00 AM	0	29	12	0	7	2	0	0	0	0	0	0	0	0	50
05:00 AM	0	88	24	1	9	1	1	0	1	0	0	0	0	5	130
06:00 AM	2	162	53	5	17	2	3	3	2	1	0	0	0	22	272
07:00 AM	5	171	57	3	30	6	1	10	2	0	0	0	2	29	316
08:00 AM	3	131	53	1	22	10	2	11	1	1	0	0	0	50	285
09:00 AM	1	160	68	2	27	7	2	14	2	1	0	0	1	37	322
10:00 AM	5	138	48	1	18	6	2	8	4	1	0	0	0	22	253
11:00 AM	1	151	55	2	26	5	6	9	3	0	0	0	0	33	291
12:00 PM	4	181	72	1	17	5	3	9	0	1	0	0	0	36	329
01:00 PM	1	195	65	6	19	5	0	8	1	0	0	0	0	38	338
02:00 PM	0	212	75	3	23	4	3	9	0	0	0	0	0	47	376
03:00 PM	3	251	61	3	35	5	2	13	1	0	0	0	0	73	447
04:00 PM	6	322	76	1	31	5	1	14	1	1	0	0	0	82	540
05:00 PM	9	348	86	0	41	2	2	9	2	0	0	0	0	73	572
06:00 PM	1	262	58	0	24	0	1	9	1	0	0	0	0	41	397
07:00 PM	2	224	33	0	12	1	4	7	2	0	0	0	0	14	299
08:00 PM	1	148	26	0	9	0	0	3	0	0	0	0	0	18	205
09:00 PM	0	105	17	0	7	0	2	2	0	0	0	0	0	7	140
10:00 PM	1	70	7	0	0	0	0	0	0	0	0	0	1	1	80
11:00 PM	0	16	3	0	0	0	0	0	0	0	0	0	0	0	19
Day Total	45	3394	956	29	379	72	35	138	24	6	0	0	4	628	5710
Percent	0.8%	59.4%	16.7%	0.5%	6.6%	1.3%	0.6%	2.4%	0.4%	0.1%	0%	0%	0.1%	11%	

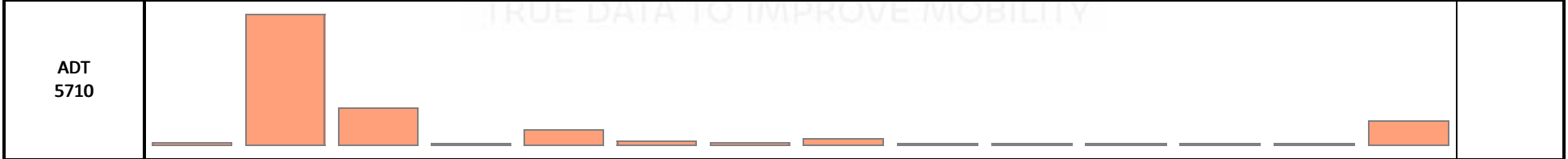

AM Peak	7:00 AM	7:00 AM	9:00 AM	6:00 AM	7:00 AM	8:00 AM	11:00 AM	9:00 AM	10:00 AM	6:00 AM	12:00 AM	12:00 AM	7:00 AM	8:00 AM	9:00 AM
Volume	5	171	68	5	30	10	6	14	4	1	0	0	2	50	322
PM Peak	5:00 PM	5:00 PM	5:00 PM	1:00 PM	5:00 PM	12:00 PM	7:00 PM	4:00 PM	5:00 PM	12:00 PM	12:00 PM	12:00 PM	10:00 PM	4:00 PM	5:00 PM
Volume	9	348	86	6	41	5	4	14	2	1	0	0	1	82	572

Comments:

LOCATION: HWY 240 btwn Illinois St and North St **QC JOB #:** 16302725
SPECIFIC LOCATION: **DIRECTION:** NB
CITY/STATE: Newberg, OR **DATE:** Sep 13 2023

Start Time	Bikes	Cars & Trailers	2 Axle Long	Buses	2 Axle 6 Tire	3 Axle Single	4 Axle Single	<5 Axl Double	5 Axle Double	>6 Axl Double	<6 Axl Multi	6 Axle Multi	>6 Axl Multi	Not Classed	Total
12:00 AM	0	9	4	0	3	0	0	0	0	0	0	0	0	0	16
01:00 AM	1	6	2	0	0	1	0	0	1	0	0	0	0	0	11
02:00 AM	0	13	6	0	1	3	0	0	0	0	0	0	0	0	23
03:00 AM	0	6	4	0	2	2	0	0	0	0	0	0	0	0	14
04:00 AM	0	25	14	0	4	4	0	0	0	1	0	0	1	3	52
05:00 AM	3	80	33	0	8	1	1	2	1	0	0	0	0	4	133
06:00 AM	6	163	49	0	10	5	3	6	0	2	0	0	2	28	274
07:00 AM	5	132	67	6	22	2	2	7	2	0	0	0	0	38	283
08:00 AM	5	162	60	4	35	11	2	14	0	0	0	0	2	32	327
09:00 AM	3	173	79	1	31	7	5	8	1	0	0	0	0	27	335
10:00 AM	3	149	41	1	29	4	4	9	1	0	0	0	1	33	275
11:00 AM	6	154	43	2	27	4	3	8	1	1	0	0	0	44	293
12:00 PM	4	198	71	3	17	3	3	13	2	0	0	1	1	32	348
01:00 PM	0	209	51	5	27	4	2	5	1	0	0	0	0	44	348
02:00 PM	2	235	70	5	21	2	5	13	0	0	0	0	1	44	398
03:00 PM	1	298	92	2	37	6	5	13	0	0	0	0	0	82	536
04:00 PM	5	316	88	1	33	3	5	17	4	1	0	0	0	79	552
05:00 PM	8	383	95	0	28	3	4	8	2	0	0	0	0	85	616
06:00 PM	5	300	59	0	26	0	3	7	0	0	0	0	0	46	446
07:00 PM	2	197	41	1	18	0	1	3	0	0	0	0	1	24	288
08:00 PM	0	176	31	0	12	0	1	0	0	0	0	0	0	10	230
09:00 PM	1	97	25	0	4	1	0	2	0	0	0	0	0	5	135
10:00 PM	0	50	9	0	3	0	0	0	0	0	0	0	0	0	62
11:00 PM	0	26	6	0	1	0	0	0	0	0	0	0	0	0	33
Day Total	60	3557	1040	31	399	66	49	135	16	5	0	1	9	660	6028
Percent	1%	59%	17.3%	0.5%	6.6%	1.1%	0.8%	2.2%	0.3%	0.1%	0%	0%	0.1%	10.9%	
ADT 6028															
AM Peak	6:00 AM	9:00 AM	9:00 AM	7:00 AM	8:00 AM	8:00 AM	9:00 AM	8:00 AM	7:00 AM	6:00 AM	12:00 AM	12:00 AM	6:00 AM	11:00 AM	9:00 AM
Volume	6	173	79	6	35	11	5	14	2	2	0	0	2	44	335
PM Peak	5:00 PM	5:00 PM	5:00 PM	1:00 PM	3:00 PM	3:00 PM	2:00 PM	4:00 PM	4:00 PM	4:00 PM	12:00 PM	12:00 PM	12:00 PM	5:00 PM	5:00 PM
Volume	8	383	95	5	37	6	5	17	4	1	0	1	1	85	616

Comments:

LOCATION: HWY 240 btwn Illinois St and North St **QC JOB #:** 16302725
SPECIFIC LOCATION: **DIRECTION:** NB
CITY/STATE: Newberg, OR **DATE:** Sep 14 2023

Start Time	Bikes	Cars & Trailers	2 Axle Long	Buses	2 Axle 6 Tire	3 Axle Single	4 Axle Single	<5 Axl Double	5 Axle Double	>6 Axl Double	<6 Axl Multi	6 Axle Multi	>6 Axl Multi	Not Classed	Total
12:00 AM	0	9	2	0	1	1	0	0	0	0	0	0	0	0	13
01:00 AM	0	6	1	0	0	1	0	0	0	0	0	0	0	1	9
02:00 AM	1	7	3	0	0	1	0	0	0	0	0	0	0	0	12
03:00 AM	0	8	5	0	1	1	0	0	1	0	0	0	0	0	16
04:00 AM	0	32	12	0	7	3	0	0	0	0	0	0	0	1	55
05:00 AM	0	108	35	0	6	2	1	1	0	0	0	0	0	5	158
06:00 AM	3	149	50	6	16	1	2	7	0	0	0	0	3	32	269
07:00 AM	6	177	58	4	11	4	8	14	2	1	0	0	0	39	324
08:00 AM	3	162	54	5	22	9	3	14	8	0	0	0	0	39	319
09:00 AM	4	146	53	3	23	5	4	9	4	1	0	0	0	32	284
10:00 AM	1	145	46	3	16	6	5	11	1	0	0	0	0	33	267
11:00 AM	1	210	58	1	22	3	3	5	3	0	0	0	0	40	346
12:00 PM	4	203	73	4	25	10	2	16	1	1	0	0	0	51	390
01:00 PM	5	205	58	8	24	4	3	11	3	0	0	0	0	68	389
02:00 PM	2	232	73	5	32	3	3	8	3	0	0	0	0	52	413
03:00 PM	6	271	84	0	32	9	5	12	3	0	0	0	0	63	485
04:00 PM	6	339	81	2	31	6	4	15	3	1	0	0	0	79	567
05:00 PM	2	372	99	2	33	3	1	20	0	0	0	0	0	83	615
06:00 PM	4	262	56	0	17	3	2	9	2	0	0	0	0	45	400
07:00 PM	3	210	45	0	16	1	3	4	0	0	0	0	0	21	303
08:00 PM	0	185	25	0	16	0	1	2	1	0	0	0	0	9	239
09:00 PM	0	119	18	0	6	0	1	1	0	0	0	0	0	0	145
10:00 PM	1	56	19	0	3	0	0	0	0	0	0	0	0	1	80
11:00 PM	1	37	6	0	0	1	0	1	0	0	0	0	0	0	46
Day Total	53	3650	1014	43	360	77	51	160	35	4	0	0	3	694	6144
Percent	0.9%	59.4%	16.5%	0.7%	5.9%	1.3%	0.8%	2.6%	0.6%	0.1%	0%	0%	0%	11.3%	
ADT 6144															
AM Peak Volume	7:00 AM 6	11:00 AM 210	7:00 AM 58	6:00 AM 6	9:00 AM 23	8:00 AM 9	7:00 AM 8	7:00 AM 14	8:00 AM 8	7:00 AM 1	12:00 AM 0	12:00 AM 0	6:00 AM 3	11:00 AM 40	11:00 AM 346
PM Peak Volume	3:00 PM 6	5:00 PM 372	5:00 PM 99	1:00 PM 8	5:00 PM 33	12:00 PM 10	3:00 PM 5	5:00 PM 20	1:00 PM 3	12:00 PM 1	12:00 PM 0	12:00 PM 0	12:00 PM 0	5:00 PM 83	5:00 PM 615

Comments:

LOCATION: HWY 240 btwn Illinois St and North St **QC JOB #:** 16302725
SPECIFIC LOCATION: **DIRECTION:** NB
CITY/STATE: Newberg, OR **DATE:** Sep 15 2023

Start Time	Bikes	Cars & Trailers	2 Axle Long	Buses	2 Axle 6 Tire	3 Axle Single	4 Axle Single	<5 Axl Double	5 Axle Double	>6 Axl Double	<6 Axl Multi	6 Axle Multi	>6 Axl Multi	Not Classed	Total
12:00 AM	0	18	2	0	1	0	0	0	0	0	0	0	0	1	22
01:00 AM	0	11	2	0	3	1	0	0	0	0	0	0	0	0	17
02:00 AM	0	5	3	1	0	4	0	0	0	0	0	0	0	0	13
03:00 AM	1	10	3	0	2	1	0	1	0	0	0	0	0	1	19
04:00 AM	1	10	5	1	6	2	0	0	0	0	0	0	0	1	26
05:00 AM	0	80	24	0	5	2	0	0	0	0	0	0	1	9	121
06:00 AM	3	143	65	6	12	5	2	4	2	0	0	0	2	23	267
07:00 AM	1	159	43	3	21	1	6	7	0	0	0	0	0	35	276
08:00 AM	5	168	55	6	32	3	4	14	7	1	0	0	0	37	332
09:00 AM	5	177	61	5	15	5	5	5	4	0	0	0	0	31	313
10:00 AM	3	170	49	2	27	3	3	15	6	0	0	0	1	33	312
11:00 AM	3	179	72	2	31	1	6	11	2	0	0	0	0	43	350
12:00 PM	4	208	62	1	30	5	2	15	1	0	0	0	0	57	385
01:00 PM	3	220	75	6	17	6	2	5	1	0	0	0	0	65	400
02:00 PM	3	260	78	3	26	6	2	12	4	1	0	0	0	74	469
03:00 PM	6	326	94	3	26	2	4	14	1	1	0	0	1	88	566
04:00 PM	6	363	99	0	28	4	4	19	1	0	0	0	0	85	609
05:00 PM	5	388	99	2	18	3	3	10	3	0	0	0	0	94	625
06:00 PM	2	304	64	0	17	3	2	6	1	0	0	0	0	51	450
07:00 PM	1	219	51	0	24	1	2	3	1	0	0	0	0	31	333
08:00 PM	0	177	37	0	11	0	1	1	0	0	0	0	0	12	239
09:00 PM	2	118	25	0	5	0	1	3	1	0	0	0	0	6	161
10:00 PM	2	78	13	0	3	0	0	1	0	0	0	0	0	6	103
11:00 PM	0	64	13	1	1	0	0	1	0	0	0	0	0	1	81
Day Total	56	3855	1094	42	361	58	49	147	35	3	0	0	5	784	6489
Percent	0.9%	59.4%	16.9%	0.6%	5.6%	0.9%	0.8%	2.3%	0.5%	0%	0%	0%	0.1%	12.1%	
ADT 6489															
AM Peak Volume	8:00 AM	11:00 AM	11:00 AM	6:00 AM	8:00 AM	6:00 AM	7:00 AM	10:00 AM	8:00 AM	8:00 AM	12:00 AM	12:00 AM	6:00 AM	11:00 AM	11:00 AM
	5	179	72	6	32	5	6	15	7	1	0	0	2	43	350
PM Peak Volume	3:00 PM	5:00 PM	4:00 PM	1:00 PM	12:00 PM	1:00 PM	3:00 PM	4:00 PM	2:00 PM	2:00 PM	12:00 PM	12:00 PM	3:00 PM	5:00 PM	5:00 PM
	6	388	99	6	30	6	4	19	4	1	0	0	1	94	625

Comments:

LOCATION: HWY 240 btwn Illinois St and North St
SPECIFIC LOCATION:
CITY/STATE: Newberg, OR

QC JOB #: 16302725
DIRECTION: NB
DATE: Sep 16 2023

Start Time	Bikes	Cars & Trailers	2 Axle Long	Buses	2 Axle 6 Tire	3 Axle Single	4 Axle Single	<5 Axl Double	5 Axle Double	>6 Axl Double	<6 Axl Multi	6 Axle Multi	>6 Axl Multi	Not Classed	Total
12:00 AM	0	24	5	0	3	0	0	0	0	0	0	0	0	0	32
01:00 AM	0	22	3	0	1	0	0	0	0	0	0	0	0	0	26
02:00 AM	1	14	3	0	0	0	0	1	0	0	0	0	0	0	19
03:00 AM	0	13	5	0	2	0	0	0	0	0	0	0	0	1	21
04:00 AM	0	6	6	0	2	0	0	0	0	0	0	0	0	0	14
05:00 AM	0	80	21	0	2	0	0	1	0	0	0	0	0	5	109
06:00 AM	0	137	39	0	3	1	0	2	0	1	0	0	0	7	190
07:00 AM	1	112	25	1	9	1	0	4	1	1	0	0	0	12	167
08:00 AM	1	192	63	0	18	2	3	10	0	0	0	0	0	23	312
09:00 AM	1	232	60	0	13	0	3	10	0	0	0	0	0	28	347
10:00 AM	6	247	40	2	20	0	4	12	1	0	0	0	0	46	378
11:00 AM	5	223	52	2	21	1	4	12	2	1	0	0	0	71	394
12:00 PM	2	250	78	1	16	2	2	10	4	0	0	0	0	63	428
01:00 PM	3	282	69	0	15	4	1	14	1	1	0	0	0	52	442
02:00 PM	3	326	56	0	24	2	5	9	0	0	0	0	0	55	480
03:00 PM	3	264	82	0	13	3	2	13	1	0	0	0	0	63	444
04:00 PM	3	254	68	1	15	0	1	8	1	0	0	0	0	57	408
05:00 PM	1	276	52	1	8	5	1	8	0	0	0	0	0	69	421
06:00 PM	1	243	42	0	14	5	1	12	0	0	0	0	0	36	354
07:00 PM	1	216	30	0	16	1	0	6	0	0	0	0	0	23	293
08:00 PM	3	161	35	0	11	0	0	6	0	1	0	0	0	18	235
09:00 PM	0	133	29	0	4	0	2	1	0	0	0	0	0	15	184
10:00 PM	1	113	11	0	5	0	0	0	0	0	0	0	0	4	134
11:00 PM	0	76	15	0	1	0	0	2	0	0	0	0	0	0	94
Day Total	36	3896	889	8	236	27	29	141	11	5	0	0	0	648	5926
Percent	0.6%	65.7%	15%	0.1%	4%	0.5%	0.5%	2.4%	0.2%	0.1%	0%	0%	0%	10.9%	
ADT 5926															
AM Peak Volume	10:00 AM 6	10:00 AM 247	8:00 AM 63	10:00 AM 2	11:00 AM 21	8:00 AM 2	10:00 AM 4	10:00 AM 12	11:00 AM 2	6:00 AM 1	12:00 AM 0	12:00 AM 0	12:00 AM 0	11:00 AM 71	11:00 AM 394
PM Peak Volume	1:00 PM 3	2:00 PM 326	3:00 PM 82	12:00 PM 1	2:00 PM 24	5:00 PM 5	2:00 PM 5	1:00 PM 14	12:00 PM 4	1:00 PM 1	12:00 PM 0	12:00 PM 0	12:00 PM 0	5:00 PM 69	2:00 PM 480

Comments:

LOCATION: HWY 240 btwn Illinois St and North St **QC JOB #:** 16302725
SPECIFIC LOCATION: **DIRECTION:** NB
CITY/STATE: Newberg, OR **DATE:** Sep 17 2023

Start Time	Bikes	Cars & Trailers	2 Axle Long	Buses	2 Axle 6 Tire	3 Axle Single	4 Axle Single	<5 Axl Double	5 Axle Double	>6 Axl Double	<6 Axl Multi	6 Axle Multi	>6 Axl Multi	Not Classed	Total
12:00 AM	1	39	9	0	2	0	0	1	0	0	0	0	0	1	53
01:00 AM	0	15	2	0	1	0	0	0	0	0	0	0	0	0	18
02:00 AM	0	15	2	0	1	0	0	0	0	0	0	0	0	0	18
03:00 AM	0	11	1	0	0	0	0	0	0	0	0	0	0	0	12
04:00 AM	0	5	5	0	1	0	0	0	0	0	0	0	0	0	11
05:00 AM	0	57	17	0	1	0	0	1	1	0	0	0	0	1	78
06:00 AM	0	106	28	0	5	0	0	1	0	0	0	0	0	1	141
07:00 AM	2	105	29	0	3	0	0	5	0	0	0	0	0	5	149
08:00 AM	1	133	38	1	13	0	0	1	0	0	0	0	0	7	194
09:00 AM	1	162	39	1	11	1	4	4	0	0	0	0	0	23	246
10:00 AM	4	197	46	0	10	1	3	6	0	0	0	0	0	27	294
11:00 AM	1	211	59	0	22	0	0	10	2	0	0	0	0	58	363
12:00 PM	3	260	61	0	15	4	1	14	0	0	0	0	0	56	414
01:00 PM	4	313	58	0	19	7	3	9	0	0	0	1	0	65	479
02:00 PM	4	229	64	1	11	0	4	15	0	0	0	0	0	66	394
03:00 PM	2	240	46	1	13	1	2	8	0	0	0	0	0	57	370
04:00 PM	2	230	45	0	14	1	2	8	0	0	0	0	0	57	359
05:00 PM	0	211	45	1	13	1	4	11	1	0	0	0	0	48	335
06:00 PM	5	221	29	0	8	2	0	6	0	0	0	0	0	23	294
07:00 PM	3	173	34	0	8	0	2	6	0	0	0	0	0	17	243
08:00 PM	1	155	27	0	7	1	0	1	0	0	0	0	0	7	199
09:00 PM	0	87	21	0	4	1	0	2	0	0	0	0	0	5	120
10:00 PM	0	44	4	0	2	0	0	0	0	0	0	0	0	1	51
11:00 PM	0	23	2	0	1	0	0	1	0	0	0	0	0	2	29
Day Total	34	3242	711	5	185	20	25	110	4	0	0	1	0	527	4864
Percent	0.7%	66.7%	14.6%	0.1%	3.8%	0.4%	0.5%	2.3%	0.1%	0%	0%	0%	0%	10.8%	
ADT 4864															
AM Peak Volume	10:00 AM 4	11:00 AM 211	11:00 AM 59	8:00 AM 1	11:00 AM 22	9:00 AM 1	9:00 AM 4	11:00 AM 10	11:00 AM 2	12:00 AM 0	12:00 AM 0	12:00 AM 0	12:00 AM 0	11:00 AM 58	11:00 AM 363
PM Peak Volume	6:00 PM 5	1:00 PM 313	2:00 PM 64	2:00 PM 1	1:00 PM 19	1:00 PM 7	2:00 PM 4	2:00 PM 15	5:00 PM 1	12:00 PM 0	12:00 PM 0	1:00 PM 1	12:00 PM 0	2:00 PM 66	1:00 PM 479

Comments:

LOCATION: HWY 240 btwn Illinois St and North St **QC JOB #:** 16302725
SPECIFIC LOCATION: **DIRECTION:** NB
CITY/STATE: Newberg, OR **DATE:** Sep 18 2023

Start Time	Bikes	Cars & Trailers	2 Axle Long	Buses	2 Axle 6 Tire	3 Axle Single	4 Axle Single	<5 Axl Double	5 Axle Double	>6 Axl Double	<6 Axl Multi	6 Axle Multi	>6 Axl Multi	Not Classed	Total
12:00 AM	0	11	2	0	3	0	0	0	0	0	0	0	0	0	16
01:00 AM	1	13	1	0	0	1	0	2	0	0	0	0	0	0	18
02:00 AM	0	5	3	1	0	3	0	0	0	0	0	0	0	0	12
03:00 AM	1	12	7	1	5	1	0	0	0	0	0	0	0	0	27
04:00 AM	0	30	5	0	5	3	1	0	0	0	0	0	0	2	46
05:00 AM	2	96	37	1	4	2	0	1	2	0	0	0	0	9	154
06:00 AM	1	174	61	7	21	0	1	6	1	1	0	0	0	26	299
07:00 AM	1	168	57	4	24	7	3	11	1	2	0	1	1	36	316
08:00 AM	1	144	63	6	33	10	2	10	2	1	0	0	0	37	309
09:00 AM	4	127	55	5	24	8	7	9	2	0	0	0	0	30	271
10:00 AM	7	156	38	0	22	5	3	9	1	1	0	0	0	32	274
11:00 AM	5	136	58	2	26	2	3	14	2	0	0	0	0	40	288
12:00 PM	2	173	59	1	24	6	5	9	1	0	0	1	0	43	324
01:00 PM	3	163	52	10	27	6	5	16	4	1	0	0	1	42	330
02:00 PM	3	231	69	5	22	2	4	11	1	1	0	0	2	38	389
03:00 PM	11	292	62	0	28	1	4	10	3	0	0	0	0	77	488
04:00 PM	7	353	92	1	28	3	8	11	0	0	0	0	0	86	589
05:00 PM	2	361	103	0	31	2	5	12	0	0	0	0	0	63	579
06:00 PM	6	240	66	2	21	0	3	6	1	0	0	0	0	37	382
07:00 PM	1	153	30	1	17	1	1	5	0	0	0	0	1	24	234
08:00 PM	1	160	23	1	6	0	1	4	0	0	0	0	0	11	207
09:00 PM	0	88	19	0	5	0	0	1	0	0	0	0	0	0	113
10:00 PM	0	55	11	0	2	0	0	0	0	0	0	0	1	0	69
11:00 PM	0	21	5	0	1	0	0	0	0	0	0	0	0	0	27
Day Total	59	3362	978	48	379	63	56	147	21	7	0	2	6	633	5761
Percent	1%	58.4%	17%	0.8%	6.6%	1.1%	1%	2.6%	0.4%	0.1%	0%	0%	0.1%	11%	
ADT 5761															
AM Peak	10:00 AM	6:00 AM	8:00 AM	6:00 AM	8:00 AM	8:00 AM	9:00 AM	11:00 AM	5:00 AM	7:00 AM	12:00 AM	7:00 AM	7:00 AM	11:00 AM	7:00 AM
Volume	7	174	63	7	33	10	7	14	2	2	0	1	1	40	316
PM Peak	3:00 PM	5:00 PM	5:00 PM	1:00 PM	5:00 PM	12:00 PM	4:00 PM	1:00 PM	1:00 PM	1:00 PM	12:00 PM	12:00 PM	2:00 PM	4:00 PM	4:00 PM
Volume	11	361	103	10	31	6	8	16	4	1	0	1	2	86	589

Comments:

LOCATION: HWY 240 btwn Illinois St and North St **QC JOB #:** 16302725
SPECIFIC LOCATION: **DIRECTION:** NB
CITY/STATE: Newberg, OR **DATE:** Sep 12 2023 - Sep 18 2023

Start Time	Bikes	Cars & Trailers	2 Axle Long	Buses	2 Axle 6 Tire	3 Axle Single	4 Axle Single	<5 Axl Double	5 Axle Double	>6 Axl Double	<6 Axl Multi	6 Axle Multi	>6 Axl Multi	Not Classed	Total
Grand Total	343	24956	6682	206	2299	383	294	978	146	30	0	4	27	4574	40922
Percent	0.8%	61%	16.3%	0.5%	5.6%	0.9%	0.7%	2.4%	0.4%	0.1%	0%	0%	0.1%	11.2%	



Comments:

LOCATION: HWY 240 btwn Grant St and Main St

QC JOB #: 16302726

SPECIFIC LOCATION:

DIRECTION: WB

CITY/STATE: Newberg, OR

DATE: Sep 12 2023

Start Time	Bikes	Cars & Trailers	2 Axle Long	Buses	2 Axle 6 Tire	3 Axle Single	4 Axle Single	<5 Axl Double	5 Axle Double	>6 Axl Double	<6 Axl Multi	6 Axle Multi	>6 Axl Multi	Not Classed	Total
12:00 AM	0	6	1	0	1	0	0	0	1	0	0	0	0	0	9
01:00 AM	0	6	1	0	2	1	0	0	0	0	0	0	0	0	10
02:00 AM	0	5	5	0	1	3	0	0	0	0	0	0	0	1	15
03:00 AM	0	5	4	0	3	2	0	0	0	0	0	0	0	0	14
04:00 AM	0	9	0	2	10	2	0	0	0	0	0	0	0	0	23
05:00 AM	1	66	25	1	13	1	0	1	1	0	0	0	0	1	110
06:00 AM	1	125	49	7	32	2	1	3	3	0	0	0	0	13	236
07:00 AM	3	108	44	5	49	4	0	4	2	0	0	0	0	30	249
08:00 AM	1	104	49	2	47	7	3	5	1	0	0	0	0	25	244
09:00 AM	0	130	59	5	52	4	1	11	3	1	0	0	0	14	280
10:00 AM	1	100	42	4	43	5	1	12	4	2	0	0	0	19	233
11:00 AM	3	123	59	5	38	2	2	5	3	0	0	0	1	12	253
12:00 PM	2	146	58	3	46	3	2	12	0	0	0	0	0	22	294
01:00 PM	2	161	52	10	53	1	0	10	0	0	0	0	0	20	309
02:00 PM	1	157	62	3	44	3	0	11	0	0	0	0	1	33	315
03:00 PM	1	223	78	3	70	8	2	7	1	1	0	1	0	38	433
04:00 PM	3	298	93	0	80	4	0	6	2	1	0	0	0	49	536
05:00 PM	0	305	89	2	82	1	0	8	1	0	0	0	0	37	525
06:00 PM	2	208	49	1	49	0	0	3	0	0	0	0	0	22	334
07:00 PM	1	158	36	0	20	2	0	5	1	0	0	0	0	8	231
08:00 PM	1	130	37	0	17	0	0	3	0	0	0	0	0	4	192
09:00 PM	0	87	19	4	15	0	1	2	0	0	0	0	0	1	129
10:00 PM	0	67	7	0	4	0	0	0	0	0	0	0	1	0	79
11:00 PM	0	15	5	0	0	0	0	0	0	0	0	0	0	1	21
Day Total	23	2742	923	57	771	55	13	108	23	5	0	1	3	350	5074
Percent	0.5%	54%	18.2%	1.1%	15.2%	1.1%	0.3%	2.1%	0.5%	0.1%	0%	0%	0.1%	6.9%	
ADT 5074															
AM Peak Volume	7:00 AM 3	9:00 AM 130	9:00 AM 59	6:00 AM 7	9:00 AM 52	8:00 AM 7	8:00 AM 3	10:00 AM 12	10:00 AM 4	10:00 AM 2	12:00 AM 0	12:00 AM 0	11:00 AM 1	7:00 AM 30	9:00 AM 280
PM Peak Volume	4:00 PM 3	5:00 PM 305	4:00 PM 93	1:00 PM 10	5:00 PM 82	3:00 PM 8	12:00 PM 2	12:00 PM 12	4:00 PM 2	3:00 PM 1	12:00 PM 0	3:00 PM 1	2:00 PM 1	4:00 PM 49	4:00 PM 536

Comments:

LOCATION: HWY 240 btwn Grant St and Main St **QC JOB #:** 16302726
SPECIFIC LOCATION: **DIRECTION:** WB
CITY/STATE: Newberg, OR **DATE:** Sep 13 2023

Start Time	Bikes	Cars & Trailers	2 Axle Long	Buses	2 Axle 6 Tire	3 Axle Single	4 Axle Single	<5 Axl Double	5 Axle Double	>6 Axl Double	<6 Axl Multi	6 Axle Multi	>6 Axl Multi	Not Classed	Total
12:00 AM	0	7	2	0	4	0	0	0	0	0	0	0	0	0	13
01:00 AM	0	8	2	1	1	1	0	0	0	0	0	0	0	0	13
02:00 AM	0	8	5	0	4	3	0	0	0	0	0	0	0	0	20
03:00 AM	0	6	3	0	4	2	0	0	0	0	0	0	0	0	15
04:00 AM	0	10	3	3	5	1	0	0	0	0	0	0	2	1	25
05:00 AM	0	62	27	0	19	1	0	2	0	0	0	0	0	5	116
06:00 AM	1	139	47	3	32	4	0	5	0	2	0	0	1	17	251
07:00 AM	1	104	46	10	48	8	2	6	1	0	0	0	0	18	244
08:00 AM	3	117	60	7	63	4	1	7	2	0	0	0	0	23	287
09:00 AM	0	151	70	6	60	6	3	6	2	0	0	0	0	12	316
10:00 AM	3	110	53	6	41	8	2	9	1	1	0	0	0	13	247
11:00 AM	0	139	47	3	41	4	1	9	3	0	0	0	0	24	271
12:00 PM	2	137	66	4	49	2	1	13	1	0	0	0	0	13	288
01:00 PM	5	157	51	10	44	4	2	4	0	0	0	0	0	22	299
02:00 PM	4	185	75	8	45	2	0	8	0	0	0	0	1	21	349
03:00 PM	2	262	94	6	68	0	2	11	0	1	0	0	0	43	489
04:00 PM	5	255	89	1	82	4	0	12	0	0	0	0	0	52	500
05:00 PM	3	310	106	1	67	3	0	4	1	0	0	0	0	32	527
06:00 PM	0	245	67	0	41	0	0	1	1	0	0	0	0	20	375
07:00 PM	1	163	42	1	23	0	0	4	0	0	0	0	2	11	247
08:00 PM	2	119	43	1	21	0	0	0	0	0	0	0	0	8	194
09:00 PM	0	69	22	0	14	0	0	1	0	0	0	0	0	1	107
10:00 PM	1	36	15	0	5	0	0	0	0	0	0	0	0	2	59
11:00 PM	0	21	7	0	1	0	0	0	0	0	0	0	0	0	29
Day Total	33	2820	1042	71	782	57	14	102	12	4	0	0	6	338	5281
Percent	0.6%	53.4%	19.7%	1.3%	14.8%	1.1%	0.3%	1.9%	0.2%	0.1%	0%	0%	0.1%	6.4%	
ADT 5281															
AM Peak Volume	8:00 AM 3	9:00 AM 151	9:00 AM 70	7:00 AM 10	8:00 AM 63	7:00 AM 8	9:00 AM 3	10:00 AM 9	11:00 AM 3	6:00 AM 2	12:00 AM 0	12:00 AM 0	4:00 AM 2	11:00 AM 24	9:00 AM 316
PM Peak Volume	1:00 PM 5	5:00 PM 310	5:00 PM 106	1:00 PM 10	4:00 PM 82	1:00 PM 4	1:00 PM 2	12:00 PM 13	12:00 PM 1	3:00 PM 1	12:00 PM 0	12:00 PM 0	7:00 PM 2	4:00 PM 52	5:00 PM 527

Comments:

LOCATION: HWY 240 btwn Grant St and Main St
SPECIFIC LOCATION:
CITY/STATE: Newberg, OR

QC JOB #: 16302726
DIRECTION: WB
DATE: Sep 14 2023

Start Time	Bikes	Cars & Trailers	2 Axle Long	Buses	2 Axle 6 Tire	3 Axle Single	4 Axle Single	<5 Axl Double	5 Axle Double	>6 Axl Double	<6 Axl Multi	6 Axle Multi	>6 Axl Multi	Not Classed	Total
12:00 AM	0	8	1	0	4	1	0	0	0	0	0	0	0	0	14
01:00 AM	0	8	1	0	0	1	0	0	0	0	0	0	0	0	10
02:00 AM	1	5	5	0	1	1	0	0	0	0	0	0	0	0	13
03:00 AM	0	6	2	0	6	1	0	0	1	0	0	0	0	0	16
04:00 AM	0	9	4	4	8	1	0	0	0	0	0	0	0	0	26
05:00 AM	1	70	41	0	17	2	0	1	0	0	0	0	0	5	137
06:00 AM	3	131	54	7	37	2	0	4	0	0	0	0	0	20	258
07:00 AM	2	136	44	7	42	1	2	6	0	1	0	0	0	22	263
08:00 AM	6	140	57	5	39	6	1	9	4	1	0	0	0	26	294
09:00 AM	2	126	51	9	46	5	2	11	4	0	0	0	0	13	269
10:00 AM	2	128	42	3	35	4	3	9	1	1	0	0	0	19	247
11:00 AM	2	167	46	1	36	2	1	8	1	2	0	0	0	14	280
12:00 PM	2	158	62	6	55	5	2	12	1	0	0	0	0	34	337
01:00 PM	1	160	49	9	50	4	0	14	1	1	0	0	0	23	312
02:00 PM	1	203	60	12	58	2	3	13	3	0	0	0	0	32	387
03:00 PM	7	244	89	3	64	4	1	9	1	0	0	0	0	43	465
04:00 PM	3	315	94	4	74	3	1	6	2	1	0	0	0	48	551
05:00 PM	2	291	106	1	78	3	0	11	0	1	0	0	0	47	540
06:00 PM	1	211	60	0	48	1	0	9	0	0	0	0	0	20	350
07:00 PM	1	155	47	0	26	0	0	6	0	0	0	0	0	16	251
08:00 PM	1	137	40	1	22	0	0	1	1	0	0	0	0	3	206
09:00 PM	0	99	21	0	11	0	0	1	0	0	0	0	0	1	133
10:00 PM	1	43	16	0	11	0	0	0	0	0	0	0	0	2	73
11:00 PM	0	32	8	1	2	0	0	2	0	0	0	0	0	1	46
Day Total	39	2982	1000	73	770	49	16	132	20	8	0	0	0	389	5478
Percent	0.7%	54.4%	18.3%	1.3%	14.1%	0.9%	0.3%	2.4%	0.4%	0.1%	0%	0%	0%	7.1%	
ADT 5478															
AM Peak Volume	8:00 AM 6	11:00 AM 167	8:00 AM 57	9:00 AM 9	9:00 AM 46	8:00 AM 6	10:00 AM 3	9:00 AM 11	8:00 AM 4	11:00 AM 2	12:00 AM 0	12:00 AM 0	12:00 AM 0	8:00 AM 26	8:00 AM 294
PM Peak Volume	3:00 PM 7	4:00 PM 315	5:00 PM 106	2:00 PM 12	5:00 PM 78	12:00 PM 5	2:00 PM 3	1:00 PM 14	2:00 PM 3	1:00 PM 1	12:00 PM 0	12:00 PM 0	12:00 PM 0	4:00 PM 48	4:00 PM 551

Comments:

LOCATION: HWY 240 btwn Grant St and Main St
SPECIFIC LOCATION:
CITY/STATE: Newberg, OR

QC JOB #: 16302726
DIRECTION: WB
DATE: Sep 15 2023

Start Time	Bikes	Cars & Trailers	2 Axle Long	Buses	2 Axle 6 Tire	3 Axle Single	4 Axle Single	<5 Axl Double	5 Axle Double	>6 Axl Double	<6 Axl Multi	6 Axle Multi	>6 Axl Multi	Not Classed	Total
12:00 AM	0	14	2	0	1	0	0	0	1	0	0	0	0	0	18
01:00 AM	0	9	3	0	4	1	0	0	0	0	0	0	0	0	17
02:00 AM	0	3	3	1	1	4	0	0	0	0	0	0	0	0	12
03:00 AM	0	8	2	1	4	0	0	1	0	0	0	0	0	1	17
04:00 AM	1	8	0	3	9	1	0	0	0	0	0	0	0	0	22
05:00 AM	0	61	33	2	11	0	0	0	0	0	0	0	1	3	111
06:00 AM	3	110	53	5	35	2	1	4	2	1	0	0	2	14	232
07:00 AM	1	132	47	5	39	1	1	4	0	0	1	0	0	26	257
08:00 AM	2	141	56	5	52	2	2	7	4	2	0	0	0	26	299
09:00 AM	5	132	48	6	33	1	3	5	3	1	0	0	1	17	255
10:00 AM	1	140	50	7	30	2	1	15	3	4	0	1	1	11	266
11:00 AM	1	155	49	2	52	3	2	9	1	0	0	0	1	30	305
12:00 PM	2	166	65	2	52	3	3	12	2	1	0	0	0	25	333
01:00 PM	4	185	71	8	50	4	1	7	1	1	0	0	0	32	364
02:00 PM	3	211	65	5	56	4	1	8	3	1	0	0	1	43	401
03:00 PM	3	311	113	8	67	5	1	8	0	0	0	0	0	44	560
04:00 PM	7	290	95	5	72	1	1	9	0	0	0	0	0	47	527
05:00 PM	5	290	86	1	72	2	0	8	2	1	0	0	0	42	509
06:00 PM	1	247	73	0	55	1	0	5	1	0	0	0	0	21	404
07:00 PM	1	161	54	1	36	0	0	1	1	0	0	0	0	5	260
08:00 PM	0	122	33	1	24	1	0	2	0	0	0	0	0	11	194
09:00 PM	1	93	21	0	11	0	0	7	0	0	0	0	0	4	137
10:00 PM	0	58	19	0	7	0	0	1	0	0	0	0	0	2	87
11:00 PM	0	43	14	1	5	0	0	2	0	0	0	0	0	1	66
Day Total	41	3090	1055	69	778	38	17	115	24	12	1	1	7	405	5653
Percent	0.7%	54.7%	18.7%	1.2%	13.8%	0.7%	0.3%	2%	0.4%	0.2%	0%	0%	0.1%	7.2%	
ADT 5653															
AM Peak Volume	9:00 AM 5	11:00 AM 155	8:00 AM 56	10:00 AM 7	8:00 AM 52	2:00 AM 4	9:00 AM 3	10:00 AM 15	8:00 AM 4	10:00 AM 4	7:00 AM 1	10:00 AM 1	6:00 AM 2	11:00 AM 30	11:00 AM 305
PM Peak Volume	4:00 PM 7	3:00 PM 311	3:00 PM 113	1:00 PM 8	4:00 PM 72	3:00 PM 5	12:00 PM 3	12:00 PM 12	2:00 PM 3	12:00 PM 1	12:00 PM 0	12:00 PM 0	2:00 PM 1	4:00 PM 47	3:00 PM 560

Comments:

LOCATION: HWY 240 btwn Grant St and Main St **QC JOB #:** 16302726
SPECIFIC LOCATION: **DIRECTION:** WB
CITY/STATE: Newberg, OR **DATE:** Sep 16 2023

Start Time	Bikes	Cars & Trailers	2 Axle Long	Buses	2 Axle 6 Tire	3 Axle Single	4 Axle Single	<5 Axl Double	5 Axle Double	>6 Axl Double	<6 Axl Multi	6 Axle Multi	>6 Axl Multi	Not Classed	Total
12:00 AM	0	18	8	0	6	1	0	0	0	0	0	0	0	2	35
01:00 AM	0	19	6	0	1	0	0	0	0	0	0	0	0	0	26
02:00 AM	1	8	5	0	0	0	0	1	0	0	0	0	0	0	15
03:00 AM	0	11	3	0	6	0	0	0	0	0	0	0	0	0	20
04:00 AM	0	3	1	0	7	1	0	0	0	0	0	0	0	0	12
05:00 AM	0	61	37	0	7	0	0	1	0	0	0	0	0	0	106
06:00 AM	0	114	40	1	12	0	0	2	0	1	0	0	0	1	171
07:00 AM	0	90	27	1	15	1	0	3	3	1	0	0	0	4	145
08:00 AM	2	108	47	1	33	2	0	11	0	0	0	0	0	11	215
09:00 AM	2	134	46	1	25	0	1	7	0	0	0	0	0	14	230
10:00 AM	1	159	48	5	40	1	0	8	1	0	0	0	0	19	282
11:00 AM	4	186	54	0	34	3	1	14	0	0	0	0	0	29	325
12:00 PM	8	206	71	3	52	1	0	12	1	0	0	0	0	32	386
01:00 PM	3	204	65	0	44	2	0	8	1	0	0	0	0	29	356
02:00 PM	3	248	74	1	43	1	0	9	0	1	0	0	0	32	412
03:00 PM	0	221	82	0	51	2	0	12	1	0	0	0	0	26	395
04:00 PM	2	212	60	2	56	1	0	7	0	0	0	0	0	31	371
05:00 PM	2	217	69	3	40	0	0	12	0	0	0	0	0	27	370
06:00 PM	4	198	71	1	34	0	0	7	0	0	0	0	0	21	336
07:00 PM	3	152	45	2	28	0	1	2	0	0	0	0	0	7	240
08:00 PM	0	123	36	0	21	0	0	3	0	0	0	1	0	6	190
09:00 PM	1	92	32	0	15	0	0	0	0	0	0	0	0	4	144
10:00 PM	2	80	22	0	9	0	0	0	0	0	0	0	0	1	114
11:00 PM	0	48	22	0	5	0	0	2	0	0	0	0	0	0	77
Day Total	38	2912	971	21	584	16	3	121	7	3	0	1	0	296	4973
Percent	0.8%	58.6%	19.5%	0.4%	11.7%	0.3%	0.1%	2.4%	0.1%	0.1%	0%	0%	0%	6%	
ADT 4973															
AM Peak Volume	11:00 AM 4	11:00 AM 186	11:00 AM 54	10:00 AM 5	10:00 AM 40	11:00 AM 3	9:00 AM 1	11:00 AM 14	7:00 AM 3	6:00 AM 1	12:00 AM 0	12:00 AM 0	12:00 AM 0	11:00 AM 29	11:00 AM 325
PM Peak Volume	12:00 PM 8	2:00 PM 248	3:00 PM 82	12:00 PM 3	4:00 PM 56	1:00 PM 2	7:00 PM 1	12:00 PM 12	12:00 PM 1	2:00 PM 1	12:00 PM 0	8:00 PM 1	12:00 PM 0	12:00 PM 32	2:00 PM 412

Comments:

LOCATION: HWY 240 btwn Grant St and Main St **QC JOB #:** 16302726
SPECIFIC LOCATION: **DIRECTION:** WB
CITY/STATE: Newberg, OR **DATE:** Sep 17 2023

Start Time	Bikes	Cars & Trailers	2 Axle Long	Buses	2 Axle 6 Tire	3 Axle Single	4 Axle Single	<5 Axl Double	5 Axle Double	>6 Axl Double	<6 Axl Multi	6 Axle Multi	>6 Axl Multi	Not Classed	Total
12:00 AM	1	19	11	1	3	0	0	0	0	0	0	0	0	2	37
01:00 AM	0	10	2	0	3	0	0	0	0	0	0	0	0	0	15
02:00 AM	0	9	3	0	1	0	0	0	0	0	0	0	0	0	13
03:00 AM	0	7	1	0	1	0	0	0	0	0	0	0	0	0	9
04:00 AM	0	3	1	0	7	0	0	0	0	0	0	0	0	0	11
05:00 AM	0	38	27	1	6	0	0	1	0	0	1	0	0	2	76
06:00 AM	0	79	32	0	12	0	0	1	0	0	0	0	0	0	124
07:00 AM	1	58	17	0	13	0	0	5	0	0	0	0	0	2	96
08:00 AM	1	91	26	2	25	0	0	0	0	0	0	0	0	3	148
09:00 AM	0	130	34	1	24	0	0	3	0	0	0	0	0	14	206
10:00 AM	1	139	48	0	37	1	0	5	1	0	0	0	0	15	247
11:00 AM	0	185	46	0	46	0	0	6	0	0	0	0	0	17	300
12:00 PM	3	179	53	0	36	0	0	12	0	0	0	0	1	30	314
01:00 PM	2	226	77	0	51	3	0	9	0	0	0	0	0	34	402
02:00 PM	4	182	66	1	42	1	0	12	0	0	0	0	0	21	329
03:00 PM	3	174	46	1	27	0	0	10	1	0	0	0	0	30	292
04:00 PM	2	173	63	0	30	0	0	5	0	1	0	0	0	19	293
05:00 PM	1	156	65	1	25	0	0	9	0	0	0	0	0	26	283
06:00 PM	1	163	36	1	23	0	0	5	0	0	0	0	0	13	242
07:00 PM	1	132	35	0	17	0	0	2	0	0	0	0	0	10	197
08:00 PM	1	109	30	0	17	0	0	4	0	0	0	0	0	2	163
09:00 PM	0	67	21	1	9	0	0	2	0	0	0	0	0	0	100
10:00 PM	0	30	8	0	3	0	0	0	0	0	0	0	0	0	41
11:00 PM	0	17	7	0	2	0	0	1	0	0	0	0	0	0	27
Day Total	22	2376	755	10	460	5	0	92	2	1	1	0	1	240	3965
Percent	0.6%	59.9%	19%	0.3%	11.6%	0.1%	0%	2.3%	0.1%	0%	0%	0%	0%	6.1%	
ADT 3965															
AM Peak	12:00 AM	11:00 AM	10:00 AM	8:00 AM	11:00 AM	10:00 AM	12:00 AM	11:00 AM	10:00 AM	12:00 AM	5:00 AM	12:00 AM	12:00 AM	11:00 AM	11:00 AM
Volume	1	185	48	2	46	1	0	6	1	0	1	0	0	17	300
PM Peak	2:00 PM	1:00 PM	1:00 PM	2:00 PM	1:00 PM	1:00 PM	12:00 PM	12:00 PM	3:00 PM	4:00 PM	12:00 PM	12:00 PM	12:00 PM	1:00 PM	1:00 PM
Volume	4	226	77	1	51	3	0	12	1	1	0	0	1	34	402

Comments:

LOCATION: HWY 240 btwn Grant St and Main St

QC JOB #: 16302726

SPECIFIC LOCATION:

DIRECTION: WB

CITY/STATE: Newberg, OR

DATE: Sep 18 2023

Start Time	Bikes	Cars & Trailers	2 Axle Long	Buses	2 Axle 6 Tire	3 Axle Single	4 Axle Single	<5 Axl Double	5 Axle Double	>6 Axl Double	<6 Axl Multi	6 Axle Multi	>6 Axl Multi	Not Classed	Total
12:00 AM	0	7	2	1	2	0	0	0	0	0	0	0	0	0	12
01:00 AM	2	7	3	0	2	1	0	0	1	0	0	0	0	0	16
02:00 AM	0	5	2	1	1	3	0	0	0	0	0	0	0	0	12
03:00 AM	0	8	6	2	11	0	0	0	0	0	0	0	0	0	27
04:00 AM	0	10	4	2	5	2	0	0	0	0	0	0	0	0	23
05:00 AM	0	57	45	2	17	4	0	2	1	0	0	0	0	9	137
06:00 AM	1	153	55	7	38	1	0	10	0	0	0	0	1	12	278
07:00 AM	4	116	53	5	49	4	2	2	1	0	0	0	0	34	270
08:00 AM	1	96	45	10	55	7	3	5	1	3	0	0	0	18	244
09:00 AM	1	96	56	6	37	7	1	5	0	0	0	1	1	24	235
10:00 AM	2	112	41	6	34	1	1	6	0	0	0	0	0	21	224
11:00 AM	1	105	42	4	40	3	1	13	1	0	0	0	0	31	241
12:00 PM	1	158	52	5	57	2	2	10	0	0	0	0	1	18	306
01:00 PM	0	135	54	11	54	3	2	15	2	0	1	0	1	23	301
02:00 PM	0	163	64	9	41	2	1	10	1	0	0	0	1	25	317
03:00 PM	2	254	84	2	52	4	1	6	0	0	0	0	0	35	440
04:00 PM	4	322	90	1	88	0	0	10	1	0	0	0	0	42	558
05:00 PM	0	301	96	2	78	0	0	10	0	0	0	0	0	32	519
06:00 PM	1	173	56	1	52	0	0	7	1	0	0	0	0	23	314
07:00 PM	0	110	37	2	34	0	0	5	0	0	0	0	1	15	204
08:00 PM	0	114	34	1	15	1	0	2	0	0	0	0	0	7	174
09:00 PM	0	68	19	0	14	0	0	2	0	0	0	0	0	2	105
10:00 PM	0	35	11	0	7	0	0	0	0	0	0	0	1	1	55
11:00 PM	0	17	4	0	3	0	0	0	0	0	0	0	0	0	24
Day Total	20	2622	955	80	786	45	14	120	10	3	1	1	7	372	5036
Percent	0.4%	52.1%	19%	1.6%	15.6%	0.9%	0.3%	2.4%	0.2%	0.1%	0%	0%	0.1%	7.4%	
ADT 5036															
AM Peak Volume	7:00 AM 4	6:00 AM 153	9:00 AM 56	8:00 AM 10	8:00 AM 55	8:00 AM 7	8:00 AM 3	11:00 AM 13	1:00 AM 1	8:00 AM 3	12:00 AM 0	9:00 AM 1	6:00 AM 1	7:00 AM 34	6:00 AM 278
PM Peak Volume	4:00 PM 4	4:00 PM 322	5:00 PM 96	1:00 PM 11	4:00 PM 88	3:00 PM 4	12:00 PM 2	1:00 PM 15	1:00 PM 2	12:00 PM 0	1:00 PM 1	12:00 PM 0	12:00 PM 1	4:00 PM 42	4:00 PM 558

Comments:

LOCATION: HWY 240 btwn Grant St and Main St **QC JOB #:** 16302726
SPECIFIC LOCATION: **DIRECTION:** WB
CITY/STATE: Newberg, OR **DATE:** Sep 12 2023 - Sep 18 2023

Start Time	Bikes	Cars & Trailers	2 Axle Long	Buses	2 Axle 6 Tire	3 Axle Single	4 Axle Single	<5 Axl Double	5 Axle Double	>6 Axl Double	<6 Axl Multi	6 Axle Multi	>6 Axl Multi	Not Classed	Total
Grand Total	216	19544	6701	381	4931	265	77	790	98	36	3	4	24	2390	35460
Percent	0.6%	55.1%	18.9%	1.1%	13.9%	0.7%	0.2%	2.2%	0.3%	0.1%	0%	0%	0.1%	6.7%	



Comments:

LOCATION: HWY 240 btwn Grant St and Main St **QC JOB #:** 16302726
SPECIFIC LOCATION: **DIRECTION:** EB
CITY/STATE: Newberg, OR **DATE:** Sep 12 2023

Start Time	Bikes	Cars & Trailers	2 Axle Long	Buses	2 Axle 6 Tire	3 Axle Single	4 Axle Single	<5 Axl Double	5 Axle Double	>6 Axl Double	<6 Axl Multi	6 Axle Multi	>6 Axl Multi	Not Classed	Total
12:00 AM	0	6	2	0	1	0	0	0	0	0	0	0	0	0	9
01:00 AM	0	3	0	0	1	0	0	0	0	0	0	0	0	0	4
02:00 AM	0	2	1	0	1	0	0	0	0	0	0	0	0	0	4
03:00 AM	0	8	6	0	3	0	0	1	1	0	0	0	0	0	19
04:00 AM	1	53	20	0	9	0	0	0	0	0	0	0	0	0	83
05:00 AM	2	92	36	2	27	3	0	1	0	4	0	0	0	4	171
06:00 AM	3	192	65	3	52	2	0	4	2	4	0	0	0	16	343
07:00 AM	7	219	89	2	38	3	0	5	2	1	0	0	1	33	400
08:00 AM	4	219	78	3	39	4	2	5	1	4	0	0	1	15	375
09:00 AM	1	177	74	2	36	4	1	8	0	2	0	0	0	14	319
10:00 AM	2	171	65	4	32	4	1	6	1	7	0	1	0	15	309
11:00 AM	3	190	61	2	33	4	0	11	4	3	0	0	0	8	319
12:00 PM	4	132	64	1	30	6	1	7	3	2	0	0	0	18	268
01:00 PM	4	175	63	1	33	5	1	7	3	1	0	0	0	13	306
02:00 PM	3	143	72	6	26	4	0	9	1	1	0	0	0	23	288
03:00 PM	3	183	63	2	47	6	1	6	2	1	0	0	1	26	341
04:00 PM	8	178	71	6	39	8	0	11	0	2	0	0	1	27	351
05:00 PM	9	202	55	0	36	3	0	4	0	0	0	0	0	31	340
06:00 PM	4	161	48	0	18	2	1	3	0	0	0	0	0	13	250
07:00 PM	1	94	28	0	14	1	0	3	2	0	0	0	0	4	147
08:00 PM	0	89	30	0	13	0	0	1	0	0	0	0	0	5	138
09:00 PM	0	47	7	0	5	0	0	2	0	0	0	0	0	2	63
10:00 PM	0	23	4	0	1	0	0	0	0	0	0	0	0	0	28
11:00 PM	0	11	1	0	1	0	0	0	0	0	0	0	0	0	13
Day Total	59	2770	1003	34	535	59	8	94	22	32	0	1	4	267	4888
Percent	1.2%	56.7%	20.5%	0.7%	10.9%	1.2%	0.2%	1.9%	0.5%	0.7%	0%	0%	0.1%	5.5%	
ADT 4888															
AM Peak Volume	7:00 AM	7:00 AM	7:00 AM	10:00 AM	6:00 AM	8:00 AM	8:00 AM	11:00 AM	11:00 AM	10:00 AM	12:00 AM	10:00 AM	7:00 AM	7:00 AM	7:00 AM
	7	219	89	4	52	4	2	11	4	7	0	1	1	33	400
PM Peak Volume	5:00 PM	5:00 PM	2:00 PM	2:00 PM	3:00 PM	4:00 PM	12:00 PM	4:00 PM	12:00 PM	12:00 PM	12:00 PM	12:00 PM	3:00 PM	5:00 PM	4:00 PM
	9	202	72	6	47	8	1	11	3	2	0	0	1	31	351

Comments:

LOCATION: HWY 240 btwn Grant St and Main St **QC JOB #:** 16302726
SPECIFIC LOCATION: **DIRECTION:** EB
CITY/STATE: Newberg, OR **DATE:** Sep 13 2023

Start Time	Bikes	Cars & Trailers	2 Axle Long	Buses	2 Axle 6 Tire	3 Axle Single	4 Axle Single	<5 Axl Double	5 Axle Double	>6 Axl Double	<6 Axl Multi	6 Axle Multi	>6 Axl Multi	Not Classed	Total
12:00 AM	0	10	0	0	1	0	0	0	0	0	0	0	0	0	11
01:00 AM	0	5	1	0	0	0	0	0	0	0	0	0	0	0	6
02:00 AM	0	4	3	0	0	0	0	0	0	1	0	0	0	0	8
03:00 AM	0	10	8	0	1	0	0	1	0	0	0	0	0	0	20
04:00 AM	0	54	14	0	6	0	0	1	0	0	0	0	0	0	75
05:00 AM	3	97	43	4	22	0	0	1	2	2	0	0	0	3	177
06:00 AM	7	180	73	5	37	1	1	10	2	4	0	0	0	14	334
07:00 AM	5	214	89	1	45	3	1	6	4	1	0	0	1	18	388
08:00 AM	3	220	91	6	46	7	2	11	1	2	0	0	1	19	409
09:00 AM	2	208	68	5	38	5	0	9	1	0	0	0	0	14	350
10:00 AM	2	162	69	5	30	5	0	11	5	3	0	0	0	18	310
11:00 AM	0	183	77	2	36	6	0	7	3	2	0	0	0	20	336
12:00 PM	3	131	48	2	33	5	0	9	1	4	0	0	0	12	248
01:00 PM	4	152	47	1	33	8	0	9	3	2	0	1	0	20	280
02:00 PM	2	185	67	7	40	6	0	9	1	1	0	0	0	18	336
03:00 PM	7	215	88	7	35	6	0	14	3	0	0	0	0	32	407
04:00 PM	5	199	75	1	38	4	0	6	0	1	0	0	0	39	368
05:00 PM	4	213	72	1	45	1	0	2	0	0	0	0	0	19	357
06:00 PM	4	152	42	0	23	0	0	3	1	0	0	1	0	17	243
07:00 PM	1	101	32	0	20	2	0	3	0	0	0	0	0	6	165
08:00 PM	1	80	26	0	4	0	0	0	0	0	0	0	0	3	114
09:00 PM	1	56	11	0	4	0	0	0	1	1	0	0	0	0	74
10:00 PM	0	35	5	0	2	0	0	1	0	0	0	0	0	3	46
11:00 PM	0	9	3	0	1	0	0	0	0	0	0	0	0	0	13
Day Total	54	2875	1052	47	540	59	4	113	28	24	0	2	2	275	5075
Percent	1.1%	56.7%	20.7%	0.9%	10.6%	1.2%	0.1%	2.2%	0.6%	0.5%	0%	0%	0%	5.4%	
ADT 5075															
AM Peak Volume	6:00 AM 7	8:00 AM 220	8:00 AM 91	8:00 AM 6	8:00 AM 46	8:00 AM 7	8:00 AM 2	8:00 AM 11	10:00 AM 5	6:00 AM 4	12:00 AM 0	12:00 AM 0	7:00 AM 1	11:00 AM 20	8:00 AM 409
PM Peak Volume	3:00 PM 7	3:00 PM 215	3:00 PM 88	2:00 PM 7	5:00 PM 45	1:00 PM 8	12:00 PM 0	3:00 PM 14	1:00 PM 3	12:00 PM 4	12:00 PM 0	1:00 PM 1	12:00 PM 0	4:00 PM 39	3:00 PM 407

Comments:

LOCATION: HWY 240 btwn Grant St and Main St
SPECIFIC LOCATION:
CITY/STATE: Newberg, OR

QC JOB #: 16302726
DIRECTION: EB
DATE: Sep 14 2023

Start Time	Bikes	Cars & Trailers	2 Axle Long	Buses	2 Axle 6 Tire	3 Axle Single	4 Axle Single	<5 Axl Double	5 Axle Double	>6 Axl Double	<6 Axl Multi	6 Axle Multi	>6 Axl Multi	Not Classed	Total
12:00 AM	0	5	2	2	0	0	0	0	0	0	0	0	0	0	9
01:00 AM	0	4	1	0	1	0	0	0	0	0	0	0	0	0	6
02:00 AM	0	7	1	0	1	0	0	0	0	0	0	0	0	0	9
03:00 AM	0	9	6	0	4	0	0	2	1	0	0	0	0	0	22
04:00 AM	0	49	14	0	12	0	0	1	0	0	0	0	0	0	76
05:00 AM	2	90	47	2	22	0	0	4	1	3	0	0	1	4	176
06:00 AM	4	168	56	1	40	0	0	4	3	3	0	0	0	13	292
07:00 AM	3	237	93	5	30	2	1	6	2	1	0	0	1	21	402
08:00 AM	2	196	90	5	36	5	0	17	3	2	0	0	1	33	390
09:00 AM	2	178	63	3	31	3	0	12	1	1	0	0	0	16	310
10:00 AM	5	185	55	0	48	6	1	12	6	3	0	0	0	13	334
11:00 AM	6	180	72	4	33	5	0	10	9	2	0	0	0	16	337
12:00 PM	2	201	57	3	37	5	1	9	3	3	0	0	0	30	351
01:00 PM	7	170	63	4	36	8	1	11	6	3	0	1	0	16	326
02:00 PM	5	190	63	10	26	4	1	13	1	2	0	0	1	32	348
03:00 PM	13	213	83	7	32	9	0	7	1	0	0	0	0	30	395
04:00 PM	6	195	75	1	30	4	1	8	0	1	0	0	0	40	361
05:00 PM	8	201	67	3	33	0	0	7	0	0	0	0	0	44	363
06:00 PM	2	161	59	1	24	1	0	5	1	0	0	0	0	16	270
07:00 PM	2	125	40	0	15	2	0	6	1	0	0	0	0	12	203
08:00 PM	0	83	33	0	13	0	0	1	0	0	0	0	0	2	132
09:00 PM	0	39	13	1	5	0	0	1	0	0	0	0	0	1	60
10:00 PM	0	34	13	0	6	0	0	0	0	0	0	0	0	1	54
11:00 PM	0	12	3	0	0	0	0	0	0	0	0	0	0	0	15
Day Total	69	2932	1069	52	515	54	6	136	39	24	0	1	4	340	5241
Percent	1.3%	55.9%	20.4%	1%	9.8%	1%	0.1%	2.6%	0.7%	0.5%	0%	0%	0.1%	6.5%	
ADT 5241															
AM Peak	11:00 AM	7:00 AM	7:00 AM	7:00 AM	10:00 AM	10:00 AM	7:00 AM	8:00 AM	11:00 AM	5:00 AM	12:00 AM	12:00 AM	5:00 AM	8:00 AM	7:00 AM
Volume	6	237	93	5	48	6	1	17	9	3	0	0	1	33	402
PM Peak	3:00 PM	3:00 PM	3:00 PM	2:00 PM	12:00 PM	3:00 PM	12:00 PM	2:00 PM	1:00 PM	12:00 PM	12:00 PM	1:00 PM	2:00 PM	5:00 PM	3:00 PM
Volume	13	213	83	10	37	9	1	13	6	3	0	1	1	44	395

Comments:

LOCATION: HWY 240 btwn Grant St and Main St

QC JOB #: 16302726

SPECIFIC LOCATION:

DIRECTION: EB

CITY/STATE: Newberg, OR

DATE: Sep 15 2023

Start Time	Bikes	Cars & Trailers	2 Axle Long	Buses	2 Axle 6 Tire	3 Axle Single	4 Axle Single	<5 Axl Double	5 Axle Double	>6 Axl Double	<6 Axl Multi	6 Axle Multi	>6 Axl Multi	Not Classed	Total
12:00 AM	0	6	0	0	0	0	0	0	0	0	0	0	0	0	6
01:00 AM	0	4	1	0	2	0	0	0	0	0	0	0	0	0	7
02:00 AM	0	4	0	0	1	0	0	0	0	0	0	0	0	0	5
03:00 AM	0	9	2	1	1	0	0	1	0	1	0	0	0	0	15
04:00 AM	0	31	14	0	10	0	0	0	0	0	0	0	0	0	55
05:00 AM	2	84	28	2	23	2	0	0	0	1	0	0	1	0	143
06:00 AM	5	140	54	5	29	2	1	4	2	3	0	0	0	13	258
07:00 AM	2	248	78	6	41	2	0	5	4	2	0	0	1	15	404
08:00 AM	5	207	79	3	44	3	0	7	4	2	0	0	1	21	376
09:00 AM	7	179	58	3	31	2	0	7	6	1	0	0	0	16	310
10:00 AM	1	194	67	2	44	1	0	10	1	3	0	0	1	11	335
11:00 AM	8	138	83	3	40	2	0	6	5	4	0	0	0	26	315
12:00 PM	6	159	65	2	30	6	2	11	3	1	0	0	0	24	309
01:00 PM	1	170	65	1	33	5	0	11	3	1	0	0	0	34	324
02:00 PM	12	171	69	5	42	4	0	13	4	0	0	0	0	30	350
03:00 PM	9	182	84	5	28	3	1	5	1	1	0	0	0	39	358
04:00 PM	7	186	64	8	36	3	0	5	0	1	0	0	0	36	346
05:00 PM	8	178	47	0	20	1	1	4	0	0	0	0	1	40	300
06:00 PM	2	173	50	2	29	0	0	7	0	0	0	0	0	23	286
07:00 PM	4	142	28	1	17	0	0	3	0	0	0	0	0	9	204
08:00 PM	1	108	26	0	10	1	0	2	0	0	0	0	0	2	150
09:00 PM	0	88	18	0	6	0	0	0	0	0	0	0	0	3	115
10:00 PM	0	58	22	0	7	0	0	0	0	0	0	0	0	2	89
11:00 PM	0	25	6	0	0	0	0	0	0	0	0	0	0	1	32
Day Total	80	2884	1008	49	524	37	5	101	33	21	0	0	5	345	5092
Percent	1.6%	56.6%	19.8%	1%	10.3%	0.7%	0.1%	2%	0.6%	0.4%	0%	0%	0.1%	6.8%	
ADT 5092															
AM Peak Volume	11:00 AM 8	7:00 AM 248	11:00 AM 83	7:00 AM 6	8:00 AM 44	8:00 AM 3	6:00 AM 1	10:00 AM 10	9:00 AM 6	11:00 AM 4	12:00 AM 0	12:00 AM 0	5:00 AM 1	11:00 AM 26	7:00 AM 404
PM Peak Volume	2:00 PM 12	4:00 PM 186	3:00 PM 84	4:00 PM 8	2:00 PM 42	12:00 PM 6	12:00 PM 2	2:00 PM 13	2:00 PM 4	12:00 PM 1	12:00 PM 0	12:00 PM 0	5:00 PM 1	5:00 PM 40	3:00 PM 358

Comments:

LOCATION: HWY 240 btwn Grant St and Main St **QC JOB #:** 16302726
SPECIFIC LOCATION: **DIRECTION:** EB
CITY/STATE: Newberg, OR **DATE:** Sep 16 2023

Start Time	Bikes	Cars & Trailers	2 Axle Long	Buses	2 Axle 6 Tire	3 Axle Single	4 Axle Single	<5 Axl Double	5 Axle Double	>6 Axl Double	<6 Axl Multi	6 Axle Multi	>6 Axl Multi	Not Classed	Total
12:00 AM	1	13	2	1	1	0	0	0	0	0	0	0	0	2	20
01:00 AM	0	11	3	0	0	0	0	0	0	0	0	0	0	0	14
02:00 AM	0	3	1	0	1	0	0	0	0	0	0	0	0	0	5
03:00 AM	0	8	5	0	1	0	0	0	0	0	0	0	0	0	14
04:00 AM	0	15	5	0	2	0	0	0	1	0	0	0	0	1	24
05:00 AM	1	25	11	2	4	0	0	2	0	0	0	0	0	1	46
06:00 AM	2	52	17	0	4	0	0	6	1	0	0	0	0	1	83
07:00 AM	2	97	33	1	22	0	0	3	0	0	0	0	0	3	161
08:00 AM	1	136	45	1	22	0	0	8	0	0	0	0	0	10	223
09:00 AM	0	202	53	0	20	2	0	9	1	2	0	0	0	15	304
10:00 AM	1	205	62	2	34	0	0	9	0	0	0	0	0	21	334
11:00 AM	6	237	81	3	25	3	1	7	1	0	0	1	0	29	394
12:00 PM	7	219	79	0	33	1	0	8	3	0	0	0	0	27	377
01:00 PM	8	205	78	1	28	3	0	6	0	1	0	0	0	24	354
02:00 PM	8	224	50	0	30	4	2	8	1	0	0	0	0	21	348
03:00 PM	6	261	71	1	33	0	0	6	0	0	1	0	0	22	401
04:00 PM	0	235	65	0	23	2	0	7	0	1	0	0	0	18	351
05:00 PM	8	232	85	0	24	2	0	5	1	0	0	0	0	24	381
06:00 PM	4	161	48	0	17	1	0	7	0	0	0	0	0	9	247
07:00 PM	5	140	40	0	18	0	0	3	0	0	0	0	0	10	216
08:00 PM	2	175	30	0	7	1	0	2	0	0	0	0	0	6	223
09:00 PM	0	125	27	2	5	0	0	1	0	0	0	0	0	10	170
10:00 PM	0	64	17	0	2	1	0	0	0	0	0	0	0	0	84
11:00 PM	0	45	11	0	1	0	0	0	0	0	0	0	0	0	57
Day Total	62	3090	919	14	357	20	3	97	9	4	1	1	0	254	4831
Percent	1.3%	64%	19%	0.3%	7.4%	0.4%	0.1%	2%	0.2%	0.1%	0%	0%	0%	5.3%	
ADT 4831															
AM Peak	11:00 AM	11:00 AM	11:00 AM	11:00 AM	10:00 AM	11:00 AM	11:00 AM	9:00 AM	4:00 AM	9:00 AM	12:00 AM	11:00 AM	12:00 AM	11:00 AM	11:00 AM
Volume	6	237	81	3	34	3	1	9	1	2	0	1	0	29	394
PM Peak	1:00 PM	3:00 PM	5:00 PM	9:00 PM	12:00 PM	2:00 PM	2:00 PM	12:00 PM	12:00 PM	1:00 PM	3:00 PM	12:00 PM	12:00 PM	12:00 PM	3:00 PM
Volume	8	261	85	2	33	4	2	8	3	1	1	0	0	27	401

Comments:

LOCATION: HWY 240 btwn Grant St and Main St **QC JOB #:** 16302726
SPECIFIC LOCATION: **DIRECTION:** EB
CITY/STATE: Newberg, OR **DATE:** Sep 17 2023

Start Time	Bikes	Cars & Trailers	2 Axle Long	Buses	2 Axle 6 Tire	3 Axle Single	4 Axle Single	<5 Axl Double	5 Axle Double	>6 Axl Double	<6 Axl Multi	6 Axle Multi	>6 Axl Multi	Not Classed	Total
12:00 AM	0	20	5	1	3	0	0	0	0	0	0	0	0	2	31
01:00 AM	0	12	1	0	0	0	0	0	0	0	0	0	0	0	13
02:00 AM	0	5	4	0	1	0	0	0	0	0	0	0	0	0	10
03:00 AM	0	7	3	0	0	0	0	0	0	0	0	0	0	0	10
04:00 AM	1	12	8	0	0	0	0	1	0	0	0	0	0	0	22
05:00 AM	0	23	8	0	3	0	0	1	0	0	0	0	0	1	36
06:00 AM	0	29	7	1	12	0	0	1	1	0	0	0	0	0	51
07:00 AM	1	76	22	0	14	0	0	2	0	0	0	0	0	1	116
08:00 AM	0	125	29	0	12	1	0	1	2	0	0	0	0	5	175
09:00 AM	5	208	56	0	16	0	0	5	2	0	0	0	0	7	299
10:00 AM	6	196	65	2	19	1	0	8	0	0	0	0	0	14	311
11:00 AM	5	246	71	0	34	0	0	7	0	0	0	0	0	8	371
12:00 PM	5	233	78	0	36	1	0	10	0	0	0	0	0	29	392
01:00 PM	8	228	55	0	24	1	0	7	1	1	0	1	0	26	352
02:00 PM	7	201	49	0	18	0	0	12	0	0	0	0	0	23	310
03:00 PM	5	211	54	0	20	1	0	6	1	0	0	1	0	22	321
04:00 PM	4	207	53	0	9	0	0	7	0	0	0	0	0	9	289
05:00 PM	6	206	52	1	20	0	0	4	1	0	0	0	0	25	315
06:00 PM	2	150	37	0	14	0	0	0	0	1	0	0	0	8	212
07:00 PM	5	107	36	0	15	1	0	1	1	0	0	0	0	10	176
08:00 PM	3	100	28	1	10	0	0	1	0	0	0	0	0	3	146
09:00 PM	0	51	18	0	5	0	0	0	0	0	0	0	0	0	74
10:00 PM	0	23	9	1	1	0	0	0	0	0	0	0	0	1	35
11:00 PM	0	16	8	0	0	0	0	0	0	0	0	0	0	0	24
Day Total	63	2692	756	7	286	6	0	74	9	2	0	2	0	194	4091
Percent	1.5%	65.8%	18.5%	0.2%	7%	0.1%	0%	1.8%	0.2%	0%	0%	0%	0%	4.7%	
ADT 4091															
AM Peak	10:00 AM	11:00 AM	11:00 AM	10:00 AM	11:00 AM	8:00 AM	12:00 AM	10:00 AM	8:00 AM	12:00 AM	12:00 AM	12:00 AM	12:00 AM	10:00 AM	11:00 AM
Volume	6	246	71	2	34	1	0	8	2	0	0	0	0	14	371
PM Peak	1:00 PM	12:00 PM	12:00 PM	5:00 PM	12:00 PM	12:00 PM	12:00 PM	2:00 PM	1:00 PM	1:00 PM	12:00 PM	1:00 PM	12:00 PM	12:00 PM	12:00 PM
Volume	8	233	78	1	36	1	0	12	1	1	0	1	0	29	392

Comments:

LOCATION: HWY 240 btwn Grant St and Main St **QC JOB #:** 16302726
SPECIFIC LOCATION: **DIRECTION:** EB
CITY/STATE: Newberg, OR **DATE:** Sep 18 2023

Start Time	Bikes	Cars & Trailers	2 Axle Long	Buses	2 Axle 6 Tire	3 Axle Single	4 Axle Single	<5 Axl Double	5 Axle Double	>6 Axl Double	<6 Axl Multi	6 Axle Multi	>6 Axl Multi	Not Classed	Total
12:00 AM	0	8	3	0	2	0	0	0	0	0	0	0	0	0	13
01:00 AM	0	3	1	0	1	0	0	1	0	0	0	0	0	0	6
02:00 AM	0	5	1	0	0	0	0	0	0	0	0	0	0	0	6
03:00 AM	0	8	8	0	2	0	0	0	0	0	0	0	0	1	19
04:00 AM	2	56	19	1	14	0	0	0	1	1	0	0	0	0	94
05:00 AM	0	87	26	2	25	2	0	1	2	2	0	0	1	5	153
06:00 AM	2	168	66	0	44	2	0	8	3	6	0	0	1	13	313
07:00 AM	4	230	79	3	38	4	0	8	3	4	0	0	1	22	396
08:00 AM	5	202	62	7	50	2	1	8	3	1	0	0	0	20	361
09:00 AM	3	168	78	7	43	4	0	7	1	0	0	0	2	21	334
10:00 AM	4	157	63	2	35	7	0	16	2	2	0	0	0	16	304
11:00 AM	8	148	78	7	35	5	2	13	2	3	0	0	0	10	311
12:00 PM	6	169	72	4	35	4	2	6	3	1	0	0	1	13	316
01:00 PM	4	163	70	3	32	7	1	17	6	2	0	0	0	14	319
02:00 PM	4	166	69	5	22	3	0	7	1	1	0	0	1	23	302
03:00 PM	1	182	80	6	39	3	1	10	6	0	0	0	1	43	372
04:00 PM	3	196	66	2	39	3	0	7	0	0	1	0	0	32	349
05:00 PM	2	186	57	0	28	1	0	8	1	0	0	0	0	30	313
06:00 PM	7	140	42	0	27	6	0	5	0	0	0	0	0	17	244
07:00 PM	5	93	35	0	15	1	0	2	0	0	0	0	1	17	169
08:00 PM	1	76	23	0	10	0	0	4	0	1	0	0	0	3	118
09:00 PM	0	65	20	0	2	0	0	0	0	0	0	0	0	2	89
10:00 PM	0	31	13	0	2	0	0	0	0	0	0	0	0	0	46
11:00 PM	0	10	3	0	1	0	0	1	0	0	0	0	0	0	15
Day Total	61	2717	1034	49	541	54	7	129	34	24	1	0	9	302	4962
Percent	1.2%	54.8%	20.8%	1%	10.9%	1.1%	0.1%	2.6%	0.7%	0.5%	0%	0%	0.2%	6.1%	
ADT 4962															
AM Peak	11:00 AM	7:00 AM	7:00 AM	8:00 AM	8:00 AM	10:00 AM	11:00 AM	10:00 AM	6:00 AM	6:00 AM	12:00 AM	12:00 AM	9:00 AM	7:00 AM	7:00 AM
Volume	8	230	79	7	50	7	2	16	3	6	0	0	2	22	396
PM Peak	6:00 PM	4:00 PM	3:00 PM	3:00 PM	3:00 PM	1:00 PM	12:00 PM	1:00 PM	1:00 PM	1:00 PM	4:00 PM	12:00 PM	12:00 PM	3:00 PM	3:00 PM
Volume	7	196	80	6	39	7	2	17	6	2	1	0	1	43	372

Comments:

LOCATION: HWY 240 btwn Grant St and Main St **QC JOB #:** 16302726
SPECIFIC LOCATION: **DIRECTION:** EB
CITY/STATE: Newberg, OR **DATE:** Sep 12 2023 - Sep 18 2023

Start Time	Bikes	Cars & Trailers	2 Axle Long	Buses	2 Axle 6 Tire	3 Axle Single	4 Axle Single	<5 Axl Double	5 Axle Double	>6 Axl Double	<6 Axl Multi	6 Axle Multi	>6 Axl Multi	Not Classed	Total
Grand Total	448	19960	6841	252	3298	289	33	744	174	131	2	7	24	1977	34180
Percent	1.3%	58.4%	20%	0.7%	9.6%	0.8%	0.1%	2.2%	0.5%	0.4%	0%	0%	0.1%	5.8%	



Comments:

Attachment B

Speed Data

Type of report: Tube Count - Speed Data

LOCATION: N Main St btwn Clifford Ct and Illinois St														QC JOB #: 16302723			
SPECIFIC LOCATION:														DIRECTION: NB			
CITY/STATE: Newberg, OR														DATE: Sep 12 2023			
Start Time	1 15	16 20	21 25	26 30	31 35	36 40	41 45	46 50	51 55	56 60	61 65	66 70	71 75	76 999	Total	Pace Speed	Number in Pace
12:00 AM	0	0	1	0	0	0	0	0	0	0	0	0	0	0	1	16-25	1
01:00 AM	0	0	1	1	0	0	0	0	0	0	0	0	0	0	2	21-30	2
02:00 AM	0	0	1	0	0	1	0	0	0	0	0	0	0	0	2	16-25	1
03:00 AM	0	0	0	0	0	0	0	0	0	0	0	0	0	0	0	1-10	0
04:00 AM	0	0	0	0	0	0	0	0	0	0	0	0	0	0	0	1-10	0
05:00 AM	0	0	0	4	1	0	0	0	0	0	0	0	0	0	5	26-35	5
06:00 AM	0	1	9	10	3	0	0	0	0	0	0	0	0	0	23	21-30	19
07:00 AM	0	7	21	34	6	1	0	0	0	0	0	0	0	0	69	21-30	55
08:00 AM	5	3	11	28	12	0	0	0	0	0	0	0	0	0	59	26-35	40
09:00 AM	9	1	2	30	15	3	0	0	0	0	0	0	0	0	60	26-35	45
10:00 AM	1	1	12	28	17	0	0	0	0	0	0	0	0	0	59	26-35	45
11:00 AM	2	4	12	35	14	2	0	0	0	0	0	0	0	0	69	26-35	49
12:00 PM	3	1	20	36	13	1	0	0	0	0	0	0	0	0	74	21-30	56
01:00 PM	3	2	23	31	15	2	1	0	0	0	0	0	0	0	77	21-30	54
02:00 PM	1	5	15	40	15	2	0	0	0	0	0	0	0	0	78	21-30	55
03:00 PM	10	4	30	44	12	1	0	0	0	0	0	0	0	0	101	21-30	74
04:00 PM	5	5	40	72	18	0	0	0	0	0	0	0	0	0	140	21-30	112
05:00 PM	6	9	53	84	15	1	1	0	0	0	0	0	0	0	169	21-30	137
06:00 PM	5	4	34	56	3	1	0	0	0	0	0	0	0	0	103	21-30	90
07:00 PM	3	2	33	47	5	0	0	0	0	0	0	0	0	0	90	21-30	80
08:00 PM	1	2	16	23	4	0	0	0	0	0	0	0	0	0	46	21-30	39
09:00 PM	2	3	8	11	3	1	0	0	0	0	0	0	0	0	28	21-30	19
10:00 PM	0	0	5	6	2	0	0	0	0	0	0	0	0	0	13	21-30	11
11:00 PM	0	0	1	3	0	0	0	0	0	0	0	0	0	0	4	21-30	4
Day Total	56	54	348	623	173	16	2	0	0	0	0	0	0	0	1272	21-30	971
Percent	4.4%	4.2%	27.4%	49%	13.6%	1.3%	0.2%	0%	0%	0%	0%	0%	0%	0%			
AM Peak Volume	9:00 AM 9	7:00 AM 7	7:00 AM 21	11:00 AM 35	10:00 AM 17	9:00 AM 3	12:00 AM 0	12:00 AM 0	12:00 AM 0	12:00 AM 0	12:00 AM 0	12:00 AM 0	12:00 AM 0	12:00 AM 0	7:00 AM 69		
PM Peak Volume	3:00 PM 10	5:00 PM 9	5:00 PM 53	5:00 PM 84	4:00 PM 18	1:00 PM 2	1:00 PM 1	12:00 PM 0	12:00 PM 0	12:00 PM 0	12:00 PM 0	12:00 PM 0	12:00 PM 0	12:00 PM 0	5:00 PM 169		
<i>Comments:</i>																	

Report generated on 9/22/2023 2:43 PM

SOURCE: Quality Counts, LLC (<http://www.qualitycounts.net>)

Type of report: Tube Count - Speed Data

LOCATION: N Main St btwn Clifford Ct and Illinois St														QC JOB #: 16302723			
SPECIFIC LOCATION:														DIRECTION: NB			
CITY/STATE: Newberg, OR														DATE: Sep 13 2023			
Start Time	1 15	16 20	21 25	26 30	31 35	36 40	41 45	46 50	51 55	56 60	61 65	66 70	71 75	76 999	Total	Pace Speed	Number in Pace
12:00 AM	0	2	1	2	0	0	0	0	0	0	0	0	0	0	5	16-25	3
01:00 AM	0	0	0	0	0	0	0	0	0	0	0	0	0	0	0	1-10	0
02:00 AM	0	0	1	1	1	0	0	0	0	0	0	0	0	0	3	21-30	2
03:00 AM	0	1	0	1	0	0	0	0	0	0	0	0	0	0	2	11-20	1
04:00 AM	0	0	1	0	0	0	0	0	0	0	0	0	0	0	1	16-25	1
05:00 AM	0	0	2	2	2	0	0	0	0	0	0	0	0	0	6	21-30	4
06:00 AM	1	0	7	10	3	0	0	0	0	0	0	0	0	0	21	21-30	17
07:00 AM	0	4	14	26	3	1	0	0	0	0	0	0	0	0	48	21-30	40
08:00 AM	9	2	21	33	10	1	0	0	0	0	0	0	0	0	76	21-30	54
09:00 AM	3	3	17	28	13	0	0	0	0	0	0	0	0	0	64	21-30	45
10:00 AM	5	3	18	19	8	1	0	0	0	0	0	0	0	0	54	21-30	37
11:00 AM	1	4	21	35	14	0	0	0	0	0	0	0	0	0	75	21-30	56
12:00 PM	1	2	8	38	12	2	1	0	0	0	0	0	0	0	64	26-35	50
01:00 PM	6	5	21	36	7	0	0	0	0	0	0	0	0	0	75	21-30	57
02:00 PM	2	6	25	38	15	1	0	0	0	0	0	0	0	0	87	21-30	63
03:00 PM	4	9	39	56	13	0	0	0	0	0	0	0	0	0	121	21-30	95
04:00 PM	8	10	50	77	28	0	0	0	0	0	0	0	0	0	173	21-30	127
05:00 PM	9	2	38	108	28	1	1	0	0	0	0	0	0	0	187	21-30	146
06:00 PM	4	4	27	60	14	0	1	0	0	0	0	0	0	0	110	21-30	87
07:00 PM	4	10	36	36	5	1	0	0	0	0	0	0	0	0	92	21-30	72
08:00 PM	0	3	16	25	7	0	0	0	0	0	0	0	0	0	51	21-30	41
09:00 PM	1	0	7	18	8	0	0	0	0	0	0	0	0	0	34	26-35	26
10:00 PM	0	0	4	2	1	3	0	0	0	0	0	0	0	0	10	21-30	6
11:00 PM	0	1	1	3	2	0	0	0	0	0	0	0	0	0	7	26-35	5
Day Total	58	71	375	654	194	11	3	0	0	0	0	0	0	0	1366	21-30	1029
Percent	4.2%	5.2%	27.5%	47.9%	14.2%	0.8%	0.2%	0%	0%	0%	0%	0%	0%	0%			
AM Peak Volume	8:00 AM	7:00 AM	8:00 AM	11:00 AM	11:00 AM	7:00 AM	12:00 AM	12:00 AM	12:00 AM	12:00 AM	12:00 AM	12:00 AM	12:00 AM	12:00 AM	8:00 AM		
	9	4	21	35	14	1	0	0	0	0	0	0	0	0	76		
PM Peak Volume	5:00 PM	4:00 PM	4:00 PM	5:00 PM	4:00 PM	10:00 PM	12:00 PM	12:00 PM	12:00 PM	12:00 PM	12:00 PM	12:00 PM	12:00 PM	12:00 PM	5:00 PM		
	9	10	50	108	28	3	1	0	0	0	0	0	0	0	187		

Report generated on 9/22/2023 2:43 PM

SOURCE: Quality Counts, LLC (<http://www.qualitycounts.net>)

Type of report: Tube Count - Speed Data

LOCATION: N Main St btwn Clifford Ct and Illinois St															QC JOB #: 16302723		
SPECIFIC LOCATION:															DIRECTION: NB		
CITY/STATE: Newberg, OR															DATE: Sep 14 2023		
Start Time	1 15	16 20	21 25	26 30	31 35	36 40	41 45	46 50	51 55	56 60	61 65	66 70	71 75	76 999	Total	Pace Speed	Number in Pace
12:00 AM	0	0	0	0	0	0	0	0	0	0	0	0	0	0	0	1-10	0
01:00 AM	0	0	0	0	0	0	0	0	0	0	0	0	0	0	0	1-10	0
02:00 AM	0	0	0	0	0	0	0	0	0	0	0	0	0	0	0	1-10	0
03:00 AM	0	0	0	0	0	0	0	0	0	0	0	0	0	0	0	1-10	0
04:00 AM	0	1	0	2	1	0	0	0	0	0	0	0	0	0	4	26-35	3
05:00 AM	0	0	3	6	0	0	0	0	0	0	0	0	0	0	9	21-30	9
06:00 AM	3	2	6	12	1	0	0	0	0	0	0	0	0	0	24	21-30	18
07:00 AM	1	1	19	29	10	1	0	0	0	0	0	0	0	0	61	21-30	48
08:00 AM	4	3	11	30	11	1	0	0	0	0	0	0	0	0	60	25-34	41
09:00 AM	2	2	12	16	9	1	0	0	0	0	0	0	0	0	42	21-30	28
10:00 AM	2	2	16	18	10	0	0	0	0	0	0	0	0	0	48	21-30	34
11:00 AM	1	3	17	34	18	3	0	0	0	0	0	0	0	0	76	26-35	52
12:00 PM	1	0	21	43	14	2	1	0	0	0	0	0	0	0	82	21-30	64
01:00 PM	1	3	16	48	15	2	1	0	0	0	0	0	0	0	86	21-30	64
02:00 PM	2	2	17	49	20	2	0	0	0	0	0	0	0	0	92	26-35	69
03:00 PM	5	2	19	52	16	1	0	0	0	0	0	0	0	0	95	21-30	71
04:00 PM	7	2	27	65	28	1	0	0	0	0	0	0	0	0	130	26-35	93
05:00 PM	8	4	30	80	35	3	0	0	0	0	0	0	0	0	160	26-35	115
06:00 PM	4	5	23	48	19	1	0	0	0	0	0	0	0	0	100	21-30	71
07:00 PM	2	1	26	30	7	0	0	0	0	0	0	0	0	0	66	21-30	56
08:00 PM	2	1	12	37	7	2	0	0	0	0	0	0	0	0	61	21-30	49
09:00 PM	0	1	9	11	4	0	0	0	0	0	0	0	0	0	25	21-30	20
10:00 PM	0	0	5	10	2	0	1	0	0	0	0	0	0	0	18	21-30	15
11:00 PM	1	0	1	0	2	0	0	0	0	0	0	0	0	0	4	26-35	2
Day Total	46	35	290	620	229	20	3	0	0	0	0	0	0	0	1243	21-30	910
Percent	3.7%	2.8%	23.3%	49.9%	18.4%	1.6%	0.2%	0%	0%	0%	0%	0%	0%	0%			
AM Peak Volume	8:00 AM	8:00 AM	7:00 AM	11:00 AM	11:00 AM	11:00 AM	12:00 AM	12:00 AM	12:00 AM	12:00 AM	12:00 AM	12:00 AM	12:00 AM	12:00 AM	12:00 AM	11:00 AM	
	4	3	19	34	18	3	0	0	0	0	0	0	0	0	76		
PM Peak Volume	5:00 PM	6:00 PM	5:00 PM	5:00 PM	5:00 PM	5:00 PM	12:00 PM	12:00 PM	12:00 PM	12:00 PM	12:00 PM	12:00 PM	12:00 PM	12:00 PM	5:00 PM		
	8	5	30	80	35	3	1	0	0	0	0	0	0	160			
<i>Comments:</i>																	

Report generated on 9/22/2023 2:43 PM

SOURCE: Quality Counts, LLC (<http://www.qualitycounts.net>)

Type of report: Tube Count - Speed Data

LOCATION: N Main St btwn Clifford Ct and Illinois St															QC JOB #: 16302723		
SPECIFIC LOCATION:															DIRECTION: NB		
CITY/STATE: Newberg, OR															DATE: Sep 15 2023		
Start Time	1 15	16 20	21 25	26 30	31 35	36 40	41 45	46 50	51 55	56 60	61 65	66 70	71 75	76 999	Total	Pace Speed	Number in Pace
12:00 AM	0	1	0	3	1	0	0	0	0	0	0	0	0	0	5	26-35	4
01:00 AM	0	0	1	0	0	0	0	0	0	0	0	0	0	0	1	16-25	1
02:00 AM	0	0	0	0	0	0	0	0	0	0	0	0	0	0	0	1-10	0
03:00 AM	0	0	0	1	0	0	0	0	0	0	0	0	0	0	1	21-30	1
04:00 AM	0	0	1	0	0	0	0	0	0	0	0	0	0	0	1	16-25	1
05:00 AM	0	0	1	3	0	0	0	0	0	0	0	0	0	0	4	21-30	4
06:00 AM	0	3	6	14	3	0	0	0	0	0	0	0	0	0	26	21-30	20
07:00 AM	7	3	12	27	4	0	0	0	0	0	0	0	0	0	53	21-30	39
08:00 AM	2	1	20	31	11	0	0	0	0	0	0	0	0	0	65	21-30	51
09:00 AM	3	1	18	22	7	0	0	0	0	0	0	0	0	0	51	21-30	40
10:00 AM	1	5	21	28	2	2	0	0	0	0	0	0	0	0	59	21-30	49
11:00 AM	5	3	22	23	9	2	0	0	0	0	0	0	0	0	64	21-30	45
12:00 PM	2	5	16	32	12	2	1	0	0	0	0	0	0	0	70	21-30	48
01:00 PM	3	1	35	36	10	0	0	0	0	0	0	0	0	0	85	21-30	71
02:00 PM	9	6	41	38	7	1	0	0	0	0	0	0	0	0	102	21-30	79
03:00 PM	5	8	29	44	26	5	1	0	0	0	0	0	0	0	118	21-30	73
04:00 PM	6	3	23	58	27	4	0	0	0	0	0	0	0	0	121	26-35	85
05:00 PM	7	1	28	76	27	5	0	0	0	0	0	0	0	0	144	21-30	104
06:00 PM	4	3	18	44	10	1	0	0	0	0	0	0	0	0	80	21-30	62
07:00 PM	1	1	31	45	8	1	0	0	0	0	0	0	0	0	87	21-30	76
08:00 PM	1	3	14	36	6	0	0	0	0	0	0	0	0	0	60	21-30	50
09:00 PM	0	5	9	18	4	1	0	0	0	0	0	0	0	0	37	21-30	27
10:00 PM	0	0	3	11	1	2	0	0	0	0	0	0	0	0	17	21-30	14
11:00 PM	0	0	6	7	3	1	0	0	0	0	0	0	0	0	17	21-30	13
Day Total	56	53	355	597	178	27	2	0	0	0	0	0	0	0	1268	21-30	952
Percent	4.4%	4.2%	28%	47.1%	14%	2.1%	0.2%	0%	0%	0%	0%	0%	0%	0%			
AM Peak Volume	7:00 AM	10:00 AM	11:00 AM	8:00 AM	8:00 AM	10:00 AM	12:00 AM	12:00 AM	12:00 AM	12:00 AM	12:00 AM	12:00 AM	12:00 AM	12:00 AM	12:00 AM	8:00 AM	
	7	5	22	31	11	2	0	0	0	0	0	0	0	0	65		
PM Peak Volume	2:00 PM	3:00 PM	2:00 PM	5:00 PM	4:00 PM	3:00 PM	12:00 PM	12:00 PM	12:00 PM	12:00 PM	12:00 PM	12:00 PM	12:00 PM	12:00 PM	5:00 PM		
	9	8	41	76	27	5	1	0	0	0	0	0	0	144			
<i>Comments:</i>																	

Report generated on 9/22/2023 2:43 PM

SOURCE: Quality Counts, LLC (<http://www.qualitycounts.net>)

Type of report: Tube Count - Speed Data

LOCATION: N Main St btwn Clifford Ct and Illinois St														QC JOB #: 16302723			
SPECIFIC LOCATION:														DIRECTION: NB			
CITY/STATE: Newberg, OR														DATE: Sep 16 2023			
Start Time	1 15	16 20	21 25	26 30	31 35	36 40	41 45	46 50	51 55	56 60	61 65	66 70	71 75	76 999	Total	Pace Speed	Number in Pace
12:00 AM	0	0	0	2	1	0	0	0	0	0	0	0	0	0	3	26-35	3
01:00 AM	0	0	0	0	2	0	0	0	0	0	0	0	0	0	2	26-35	2
02:00 AM	0	0	1	3	0	0	0	0	0	0	0	0	0	0	4	21-30	4
03:00 AM	0	0	0	1	1	0	0	0	0	0	0	0	0	0	2	26-35	2
04:00 AM	0	1	0	2	0	0	0	0	0	0	0	0	0	0	3	21-30	2
05:00 AM	0	0	1	3	0	0	0	0	0	0	0	0	0	0	4	21-30	4
06:00 AM	0	1	6	7	3	0	0	0	0	0	0	0	0	0	17	21-30	13
07:00 AM	1	1	5	6	4	0	0	0	0	0	0	0	0	0	17	21-30	11
08:00 AM	2	4	36	73	30	2	0	0	0	0	0	0	0	0	147	21-30	109
09:00 AM	11	13	36	64	30	1	0	0	0	0	0	0	0	0	155	21-30	100
10:00 AM	12	7	33	72	20	0	1	0	0	0	0	0	0	0	145	21-30	105
11:00 AM	4	5	32	54	23	2	0	0	0	0	0	0	0	0	120	21-30	86
12:00 PM	12	3	12	47	9	0	0	0	0	0	0	0	0	0	83	21-30	59
01:00 PM	6	1	24	69	20	3	0	0	0	0	0	0	0	0	123	21-30	93
02:00 PM	2	1	21	50	21	1	0	0	0	0	0	0	0	0	96	25-34	71
03:00 PM	6	1	19	47	17	2	0	0	0	0	0	0	0	0	92	21-30	66
04:00 PM	4	11	28	38	10	0	0	1	0	0	0	0	0	0	92	21-30	66
05:00 PM	10	6	27	37	8	1	0	0	0	0	0	0	0	0	89	21-30	64
06:00 PM	2	1	26	39	8	1	0	0	0	0	0	0	0	0	77	21-30	65
07:00 PM	1	2	21	32	6	0	0	0	0	0	0	0	0	0	62	21-30	53
08:00 PM	0	0	16	33	6	0	0	0	0	0	0	0	0	0	55	21-30	49
09:00 PM	3	4	11	21	2	0	0	0	0	0	0	0	0	0	41	21-30	32
10:00 PM	0	1	7	9	7	0	0	0	0	0	0	0	0	0	24	21-30	16
11:00 PM	0	1	4	13	1	0	0	0	0	0	0	0	0	0	19	21-30	17
Day Total	76	64	366	722	229	13	1	1	0	0	0	0	0	0	1472	21-30	1088
Percent	5.2%	4.3%	24.9%	49%	15.6%	0.9%	0.1%	0.1%	0%	0%	0%	0%	0%	0%			
AM Peak Volume	10:00 AM	9:00 AM	8:00 AM	8:00 AM	8:00 AM	8:00 AM	10:00 AM	12:00 AM	12:00 AM	12:00 AM	12:00 AM	12:00 AM	12:00 AM	12:00 AM	9:00 AM		
	12	13	36	73	30	2	1	0	0	0	0	0	0	0	155		
PM Peak Volume	12:00 PM	4:00 PM	4:00 PM	1:00 PM	2:00 PM	1:00 PM	12:00 PM	4:00 PM	12:00 PM	12:00 PM	12:00 PM	12:00 PM	12:00 PM	12:00 PM	1:00 PM		
	12	11	28	69	21	3	0	1	0	0	0	0	0	0	123		

Report generated on 9/22/2023 2:43 PM

SOURCE: Quality Counts, LLC (<http://www.qualitycounts.net>)

Type of report: Tube Count - Speed Data

LOCATION: N Main St btwn Clifford Ct and Illinois St														QC JOB #: 16302723			
SPECIFIC LOCATION:														DIRECTION: NB			
CITY/STATE: Newberg, OR														DATE: Sep 17 2023			
Start Time	1 15	16 20	21 25	26 30	31 35	36 40	41 45	46 50	51 55	56 60	61 65	66 70	71 75	76 999	Total	Pace Speed	Number in Pace
12:00 AM	0	2	5	10	0	2	0	0	0	0	0	0	0	0	19	21-30	15
01:00 AM	0	0	0	2	0	0	0	0	0	0	0	0	0	0	2	21-30	2
02:00 AM	0	0	2	3	0	0	0	0	0	0	0	0	0	0	5	21-30	5
03:00 AM	0	0	2	2	0	0	0	0	0	0	0	0	0	0	4	21-30	4
04:00 AM	0	0	0	1	0	0	0	0	0	0	0	0	0	0	1	21-30	1
05:00 AM	0	0	1	2	0	0	0	0	0	0	0	0	0	0	3	21-30	3
06:00 AM	3	0	5	11	1	0	0	0	0	0	0	0	0	0	20	21-30	16
07:00 AM	2	3	24	30	6	0	0	0	0	0	0	0	0	0	65	21-30	54
08:00 AM	1	3	13	27	6	1	1	0	0	0	0	0	0	0	52	21-30	40
09:00 AM	6	1	15	31	11	2	0	0	0	0	0	0	0	0	66	21-30	46
10:00 AM	0	4	20	46	22	1	0	0	0	0	0	0	0	0	93	26-35	68
11:00 AM	5	3	24	56	27	2	0	0	0	0	0	0	0	1	118	26-35	83
12:00 PM	9	5	30	79	18	2	0	0	0	0	0	0	0	0	143	21-30	109
01:00 PM	4	4	42	62	11	2	0	0	0	0	0	0	0	0	125	21-30	104
02:00 PM	7	4	27	43	13	2	0	0	0	0	0	0	0	0	96	21-30	70
03:00 PM	2	5	26	45	13	0	0	0	0	0	0	0	0	0	91	21-30	71
04:00 PM	0	6	30	52	8	1	0	0	0	0	0	0	0	0	97	21-30	82
05:00 PM	9	5	29	49	13	1	0	0	0	0	0	0	0	0	106	21-30	78
06:00 PM	4	6	22	33	7	1	0	0	0	0	0	0	0	0	73	21-30	55
07:00 PM	2	3	30	31	6	0	0	0	0	0	0	0	0	0	72	21-30	61
08:00 PM	1	1	14	27	4	0	0	0	0	0	0	0	0	0	47	21-30	41
09:00 PM	1	0	9	5	6	0	0	0	0	0	0	0	0	0	21	21-30	14
10:00 PM	0	1	1	5	3	2	1	0	0	0	0	0	0	0	13	26-35	8
11:00 PM	0	0	3	4	0	0	0	0	0	0	0	0	0	0	7	21-30	7
Day Total	56	56	374	656	175	19	2	0	0	0	0	0	0	1	1339	21-30	1030
Percent	4.2%	4.2%	27.9%	49%	13.1%	1.4%	0.1%	0%	0%	0%	0%	0%	0%	0.1%			
AM Peak Volume	9:00 AM	10:00 AM	7:00 AM	11:00 AM	11:00 AM	12:00 AM	8:00 AM	12:00 AM	12:00 AM	12:00 AM	12:00 AM	12:00 AM	12:00 AM	12:00 AM	11:00 AM	11:00 AM	
	6	4	24	56	27	2	1	0	0	0	0	0	0	0	1	118	
PM Peak Volume	12:00 PM	4:00 PM	1:00 PM	12:00 PM	12:00 PM	12:00 PM	10:00 PM	12:00 PM	12:00 PM	12:00 PM	12:00 PM	12:00 PM	12:00 PM	12:00 PM	12:00 PM	12:00 PM	
	9	6	42	79	18	2	1	0	0	0	0	0	0	0	0	143	
<i>Comments:</i>																	

Report generated on 9/22/2023 2:43 PM

SOURCE: Quality Counts, LLC (<http://www.qualitycounts.net>)

Type of report: Tube Count - Speed Data

LOCATION: N Main St btwn Clifford Ct and Illinois St															QC JOB #: 16302723		
SPECIFIC LOCATION:															DIRECTION: NB		
CITY/STATE: Newberg, OR															DATE: Sep 18 2023		
Start Time	1 15	16 20	21 25	26 30	31 35	36 40	41 45	46 50	51 55	56 60	61 65	66 70	71 75	76 999	Total	Pace Speed	Number in Pace
12:00 AM	0	0	1	1	0	0	0	0	0	0	0	0	0	0	2	21-30	2
01:00 AM	0	0	1	2	0	0	0	0	0	0	0	0	0	0	3	21-30	3
02:00 AM	1	0	0	0	0	0	0	0	0	0	0	0	0	0	1	1-10	1
03:00 AM	0	0	0	0	0	0	0	0	0	0	0	0	0	0	0	1-10	0
04:00 AM	0	0	0	1	0	0	0	0	0	0	0	0	0	0	1	21-30	1
05:00 AM	0	0	4	1	1	0	0	0	0	0	0	0	0	0	6	21-30	5
06:00 AM	0	1	8	5	4	0	0	0	0	0	0	0	0	0	18	21-30	13
07:00 AM	3	3	23	33	8	1	0	0	0	0	0	0	0	0	71	21-30	56
08:00 AM	1	5	23	23	6	1	0	0	0	0	0	0	0	0	59	21-30	46
09:00 AM	6	4	29	18	3	1	0	0	0	0	0	0	0	0	61	21-30	47
10:00 AM	4	5	18	32	3	0	0	0	0	0	0	0	0	0	62	21-30	50
11:00 AM	5	2	24	24	2	2	0	0	0	0	0	0	0	0	59	21-30	48
12:00 PM	2	0	18	26	10	2	0	0	0	0	0	0	0	0	58	21-30	44
01:00 PM	7	1	31	42	13	0	0	0	0	0	0	0	0	0	94	21-30	73
02:00 PM	4	4	24	31	8	2	0	0	0	0	0	0	0	0	73	21-30	55
03:00 PM	4	7	18	43	18	1	0	0	0	0	0	0	0	0	91	21-30	61
04:00 PM	7	4	19	73	23	1	0	0	0	0	0	0	0	0	127	26-35	96
05:00 PM	7	2	23	67	34	0	0	0	0	0	0	0	0	0	133	26-35	101
06:00 PM	3	1	33	55	10	0	0	0	0	0	0	0	0	0	102	21-30	88
07:00 PM	2	6	19	26	6	0	0	0	0	0	0	0	0	0	59	21-30	45
08:00 PM	0	0	14	21	4	0	0	0	0	0	0	0	0	0	39	21-30	35
09:00 PM	0	1	14	19	2	0	0	0	0	0	0	0	0	0	36	21-30	33
10:00 PM	0	0	6	6	2	1	0	0	0	0	0	0	0	0	15	21-30	12
11:00 PM	0	1	1	1	0	0	0	0	0	0	0	0	0	0	3	16-25	2
Day Total	56	47	351	550	157	12	0	0	0	0	0	0	0	0	1173	21-30	901
Percent	4.8%	4%	29.9%	46.9%	13.4%	1%	0%	0%	0%	0%	0%	0%	0%	0%			
AM Peak Volume	9:00 AM	8:00 AM	9:00 AM	7:00 AM	7:00 AM	11:00 AM	12:00 AM	12:00 AM	12:00 AM	12:00 AM	12:00 AM	12:00 AM	12:00 AM	12:00 AM	12:00 AM	7:00 AM	
	6	5	29	33	8	2	0	0	0	0	0	0	0	0	71		
PM Peak Volume	1:00 PM	3:00 PM	6:00 PM	4:00 PM	5:00 PM	12:00 PM	12:00 PM	12:00 PM	12:00 PM	12:00 PM	12:00 PM	12:00 PM	12:00 PM	12:00 PM	5:00 PM		
	7	7	33	73	34	2	0	0	0	0	0	0	0	133			
<i>Comments:</i>																	

Report generated on 9/22/2023 2:43 PM

SOURCE: Quality Counts, LLC (<http://www.qualitycounts.net>)

SUMMARY - Tube Count - Speed Data

LOCATION: N Main St btwn Clifford Ct and Illinois St														QC JOB #: 16302723			
SPECIFIC LOCATION:														DIRECTION: NB			
CITY/STATE: Newberg, OR														DATE: Sep 12 2023 - Sep 18 2023			
Speed Range	1 15	16 20	21 25	26 30	31 35	36 40	41 45	46 50	51 55	56 60	61 65	66 70	71 75	76 999	Total	Pace Speed	Number in Pace
Grand Total	404	380	2459	4422	1335	118	13	1	0	0	0	0	0	1	9133	21-30	6881
Percent	4.4%	4.2%	26.9%	48.4%	14.6%	1.3%	0.1%	0%	0%	0%	0%	0%	0%	0%			
Cumulative Percent	4.4%	8.6%	35.5%	83.9%	98.5%	99.8%	100%	100%	100%	100%	100%	100%	100%	100%			
ADT 1304															85th Percentile: 30 MPH Mean Speed(Average): 26 MPH Median: 26 MPH Mode: 28 MPH		
<i>Comments:</i>																	

Report generated on 9/22/2023 2:43 PM

SOURCE: Quality Counts, LLC (<http://www.qualitycounts.net>)

TRUE DATA TO IMPROVE MOBILITY

Type of report: Tube Count - Speed Data

LOCATION: N Main St btwn Clifford Ct and Illinois St															QC JOB #: 16302723		
SPECIFIC LOCATION:															DIRECTION: SB		
CITY/STATE: Newberg, OR															DATE: Sep 12 2023		
Start Time	1 15	16 20	21 25	26 30	31 35	36 40	41 45	46 50	51 55	56 60	61 65	66 70	71 75	76 999	Total	Pace Speed	Number in Pace
12:00 AM	0	0	0	0	0	0	0	0	0	0	0	0	0	0	0	1-10	0
01:00 AM	0	0	0	1	0	0	0	0	0	0	0	0	0	0	1	21-30	1
02:00 AM	0	0	0	1	0	0	0	0	0	0	0	0	0	1	21-30	1	
03:00 AM	0	0	2	0	1	0	0	0	0	0	0	0	0	3	16-25	2	
04:00 AM	0	0	1	3	1	0	0	0	0	0	0	0	0	5	23-32	4	
05:00 AM	0	2	2	13	2	1	0	0	0	0	0	0	0	20	26-35	15	
06:00 AM	0	2	15	21	6	1	0	0	0	0	0	0	0	45	21-30	36	
07:00 AM	2	1	34	40	8	0	0	0	0	0	0	0	0	85	21-30	74	
08:00 AM	2	2	27	34	12	2	0	0	0	0	0	0	0	79	21-30	61	
09:00 AM	2	1	17	35	14	5	0	0	0	0	0	0	0	74	21-30	52	
10:00 AM	2	2	14	26	13	5	1	0	0	0	0	0	0	63	21-30	40	
11:00 AM	0	1	17	27	9	0	0	0	0	0	0	0	0	54	21-30	44	
12:00 PM	3	1	21	28	5	0	0	0	0	0	0	0	0	58	21-30	49	
01:00 PM	1	0	12	29	13	0	0	0	0	0	0	0	0	55	26-35	42	
02:00 PM	2	0	15	38	9	2	0	0	0	0	0	0	0	66	21-30	53	
03:00 PM	8	8	25	43	6	1	0	0	0	0	0	0	0	91	21-30	68	
04:00 PM	3	2	18	42	13	1	0	0	0	0	0	0	0	79	21-30	60	
05:00 PM	6	3	22	52	8	1	0	0	0	0	0	0	0	92	21-30	74	
06:00 PM	0	5	25	38	14	2	0	0	0	0	0	0	0	84	21-30	63	
07:00 PM	1	1	18	27	7	0	0	0	0	0	0	0	1	55	21-30	45	
08:00 PM	1	3	10	17	4	0	0	0	0	0	0	0	0	35	21-30	27	
09:00 PM	1	1	6	15	4	0	0	0	0	0	0	0	0	27	21-30	21	
10:00 PM	0	0	2	4	1	0	0	0	0	0	0	0	0	7	21-30	6	
11:00 PM	0	0	0	2	0	0	1	0	0	0	0	0	0	3	21-30	2	
Day Total	34	35	303	536	150	21	2	0	0	0	0	0	0	1	1082	21-30	839
Percent	3.1%	3.2%	28%	49.5%	13.9%	1.9%	0.2%	0%	0%	0%	0%	0%	0%	0.1%			
AM Peak Volume	7:00 AM 2	5:00 AM 2	7:00 AM 34	7:00 AM 40	9:00 AM 14	9:00 AM 5	10:00 AM 1	12:00 AM 0	12:00 AM 0	12:00 AM 0	12:00 AM 0	12:00 AM 0	12:00 AM 0	12:00 AM 0	7:00 AM 85		
PM Peak Volume	3:00 PM 8	3:00 PM 8	3:00 PM 25	5:00 PM 52	6:00 PM 14	2:00 PM 2	11:00 PM 1	12:00 PM 0	12:00 PM 0	12:00 PM 0	12:00 PM 0	12:00 PM 0	12:00 PM 0	7:00 PM 1	5:00 PM 92		
<i>Comments:</i>																	

Report generated on 9/22/2023 2:43 PM

SOURCE: Quality Counts, LLC (<http://www.qualitycounts.net>)

Type of report: Tube Count - Speed Data

LOCATION: N Main St btwn Clifford Ct and Illinois St															QC JOB #: 16302723		
SPECIFIC LOCATION:															DIRECTION: SB		
CITY/STATE: Newberg, OR															DATE: Sep 13 2023		
Start Time	1 15	16 20	21 25	26 30	31 35	36 40	41 45	46 50	51 55	56 60	61 65	66 70	71 75	76 999	Total	Pace Speed	Number in Pace
12:00 AM	0	0	0	0	0	0	0	0	0	0	0	0	0	0	0	1-10	0
01:00 AM	0	0	0	0	0	0	0	1	0	0	0	0	0	0	1	41-50	1
02:00 AM	0	0	0	1	0	0	0	0	0	0	0	0	0	0	1	21-30	1
03:00 AM	0	0	0	1	1	0	0	0	0	0	0	0	0	0	2	26-35	2
04:00 AM	0	0	2	3	4	0	0	0	0	0	0	0	0	0	9	26-35	7
05:00 AM	0	1	5	10	2	1	0	0	0	0	0	0	0	0	19	21-30	15
06:00 AM	1	1	8	15	6	0	0	0	0	0	0	0	0	0	31	21-30	23
07:00 AM	1	2	26	34	9	1	0	0	0	0	0	0	0	0	73	21-30	60
08:00 AM	4	5	32	40	7	0	0	0	0	0	0	0	0	0	88	21-30	72
09:00 AM	1	2	16	33	9	2	0	0	0	0	0	0	0	0	63	21-30	49
10:00 AM	0	1	13	26	12	3	0	0	0	0	0	0	0	0	55	21-30	39
11:00 AM	2	2	12	23	12	1	0	0	0	0	0	0	0	0	52	21-30	35
12:00 PM	0	0	7	33	10	1	0	1	0	0	0	0	0	0	52	26-35	43
01:00 PM	2	4	20	26	5	2	0	0	0	0	0	0	0	0	59	21-30	46
02:00 PM	3	4	23	28	13	0	0	0	0	0	0	0	0	0	71	21-30	51
03:00 PM	8	6	22	40	14	0	0	0	0	0	0	0	0	0	90	21-30	62
04:00 PM	1	1	24	27	12	1	0	0	0	0	0	0	0	0	66	21-30	51
05:00 PM	12	1	20	36	22	0	0	0	0	0	0	0	0	0	91	26-35	58
06:00 PM	4	5	35	76	15	0	0	0	0	0	0	0	0	0	135	21-30	111
07:00 PM	4	0	19	24	7	0	0	0	0	0	0	0	0	0	54	21-30	43
08:00 PM	0	2	8	14	2	1	0	0	0	0	0	0	0	0	27	21-30	22
09:00 PM	0	1	5	8	2	0	0	0	0	0	0	0	0	0	16	21-30	13
10:00 PM	0	0	0	3	0	0	0	0	0	0	0	0	0	0	3	21-30	3
11:00 PM	0	0	2	5	1	0	0	0	0	0	0	0	0	0	8	21-30	7
Day Total	43	38	299	506	165	13	0	2	0	0	0	0	0	0	1066	21-30	805
Percent	4%	3.6%	28%	47.5%	15.5%	1.2%	0%	0.2%	0%	0%	0%	0%	0%	0%			
AM Peak Volume	8:00 AM 4	8:00 AM 5	8:00 AM 32	8:00 AM 40	10:00 AM 12	10:00 AM 3	12:00 AM 0	1:00 AM 1	12:00 AM 0	12:00 AM 0	12:00 AM 0	12:00 AM 0	12:00 AM 0	12:00 AM 0	8:00 AM 88		
PM Peak Volume	5:00 PM 12	3:00 PM 6	6:00 PM 35	6:00 PM 76	5:00 PM 22	1:00 PM 2	12:00 PM 0	12:00 PM 1	12:00 PM 0	12:00 PM 0	12:00 PM 0	12:00 PM 0	12:00 PM 0	12:00 PM 0	6:00 PM 135		
<i>Comments:</i>																	

Report generated on 9/22/2023 2:43 PM

SOURCE: Quality Counts, LLC (<http://www.qualitycounts.net>)

Type of report: Tube Count - Speed Data

LOCATION: N Main St btwn Clifford Ct and Illinois St															QC JOB #: 16302723		
SPECIFIC LOCATION:															DIRECTION: SB		
CITY/STATE: Newberg, OR															DATE: Sep 14 2023		
Start Time	1 15	16 20	21 25	26 30	31 35	36 40	41 45	46 50	51 55	56 60	61 65	66 70	71 75	76 999	Total	Pace Speed	Number in Pace
12:00 AM	0	0	0	0	0	0	0	0	0	0	0	0	0	0	0	1-10	0
01:00 AM	0	0	0	0	0	0	0	0	0	0	0	0	0	0	0	1-10	0
02:00 AM	0	0	0	1	1	0	0	0	0	0	0	0	0	0	2	26-35	2
03:00 AM	0	0	1	1	0	0	0	0	0	0	0	0	0	0	2	21-30	2
04:00 AM	0	0	3	5	1	0	0	0	0	0	0	0	0	0	9	21-30	8
05:00 AM	0	1	6	9	3	0	0	0	0	0	0	0	0	0	19	21-30	15
06:00 AM	0	4	13	20	4	0	0	0	0	0	0	0	0	0	41	21-30	33
07:00 AM	5	12	19	38	10	0	0	0	1	0	0	0	0	0	85	21-30	57
08:00 AM	2	1	12	33	11	1	0	0	0	0	0	0	0	0	60	21-30	45
09:00 AM	1	1	10	28	7	1	0	0	0	0	0	0	0	0	48	21-30	38
10:00 AM	0	1	14	32	21	0	0	0	0	0	0	0	0	0	68	26-35	53
11:00 AM	3	2	7	22	14	0	0	0	0	0	0	0	0	0	48	26-35	36
12:00 PM	2	2	12	24	7	0	0	0	0	0	0	0	0	0	47	21-30	36
01:00 PM	0	2	12	25	11	3	0	0	0	0	0	0	0	0	53	21-30	37
02:00 PM	2	2	11	24	11	1	0	0	0	0	0	0	0	0	51	22-31	35
03:00 PM	1	6	20	34	15	0	0	0	0	0	0	0	0	0	76	21-30	54
04:00 PM	5	1	9	40	8	2	0	0	0	0	0	0	0	0	65	21-30	49
05:00 PM	4	0	20	48	17	0	0	0	0	0	0	0	0	0	89	21-30	68
06:00 PM	1	6	21	43	10	2	0	0	0	0	0	0	0	0	83	21-30	64
07:00 PM	6	1	14	17	10	1	0	0	0	0	0	0	0	0	49	21-30	31
08:00 PM	1	4	16	11	3	0	0	0	0	0	0	0	0	0	35	21-30	27
09:00 PM	6	2	5	10	3	0	0	0	0	0	0	0	0	0	26	21-30	15
10:00 PM	0	0	2	2	1	0	0	0	0	0	0	0	0	0	5	21-30	4
11:00 PM	0	0	1	0	3	0	0	0	0	0	0	0	0	0	4	26-35	3
Day Total	39	48	228	467	171	11	0	0	1	0	0	0	0	0	965	21-30	695
Percent	4%	5%	23.6%	48.4%	17.7%	1.1%	0%	0%	0.1%	0%	0%	0%	0%	0%			
AM Peak Volume	7:00 AM	7:00 AM	7:00 AM	7:00 AM	10:00 AM	8:00 AM	12:00 AM	12:00 AM	7:00 AM	12:00 AM	12:00 AM	12:00 AM	12:00 AM	12:00 AM	7:00 AM		
	5	12	19	38	21	1	0	0	1	0	0	0	0	0	85		
PM Peak Volume	7:00 PM	3:00 PM	6:00 PM	5:00 PM	5:00 PM	1:00 PM	12:00 PM	12:00 PM	12:00 PM	12:00 PM	12:00 PM	12:00 PM	12:00 PM	12:00 PM	5:00 PM		
	6	6	21	48	17	3	0	0	0	0	0	0	0	0	89		
<i>Comments:</i>																	

Report generated on 9/22/2023 2:43 PM

SOURCE: Quality Counts, LLC (<http://www.qualitycounts.net>)

Type of report: Tube Count - Speed Data

LOCATION: N Main St btwn Clifford Ct and Illinois St														QC JOB #: 16302723			
SPECIFIC LOCATION:														DIRECTION: SB			
CITY/STATE: Newberg, OR														DATE: Sep 15 2023			
Start Time	1 15	16 20	21 25	26 30	31 35	36 40	41 45	46 50	51 55	56 60	61 65	66 70	71 75	76 999	Total	Pace Speed	Number in Pace
12:00 AM	0	0	2	1	0	0	1	0	0	0	0	0	0	0	4	21-30	3
01:00 AM	1	0	0	1	0	0	0	0	0	0	0	0	0	0	2	21-30	1
02:00 AM	0	0	0	2	1	0	0	0	0	0	0	0	0	0	3	26-35	3
03:00 AM	0	0	0	0	0	0	0	0	0	0	0	0	0	0	0	1-10	0
04:00 AM	0	0	1	1	1	1	0	0	0	0	0	0	0	0	4	21-30	2
05:00 AM	0	0	2	5	4	0	0	0	0	0	0	0	0	0	11	26-35	9
06:00 AM	0	0	18	23	7	0	0	0	0	0	0	0	0	0	48	21-30	41
07:00 AM	1	5	21	42	10	0	0	0	0	0	0	0	0	0	79	21-30	63
08:00 AM	1	1	17	35	16	2	0	0	0	0	0	0	0	0	72	21-30	52
09:00 AM	0	2	13	28	14	1	0	0	0	0	0	0	0	0	58	26-35	42
10:00 AM	4	3	19	42	8	0	0	0	0	0	0	0	0	0	76	21-30	61
11:00 AM	3	7	36	29	5	1	1	0	0	0	0	0	0	0	82	21-30	65
12:00 PM	3	8	20	26	9	0	0	0	0	0	0	0	0	0	66	21-30	46
01:00 PM	4	11	27	19	4	1	0	0	0	0	0	0	0	0	66	21-30	46
02:00 PM	5	5	20	27	6	1	0	0	0	0	0	0	0	0	64	21-30	47
03:00 PM	1	7	18	31	15	0	0	0	0	0	0	0	0	0	72	21-30	49
04:00 PM	4	3	14	30	13	3	1	0	0	0	0	0	0	0	68	21-30	44
05:00 PM	8	7	25	48	17	2	1	0	0	0	0	0	0	0	108	21-30	73
06:00 PM	3	4	19	26	8	1	0	0	0	0	0	0	0	0	61	21-30	45
07:00 PM	0	0	16	26	7	0	0	0	0	0	0	0	0	0	49	21-30	42
08:00 PM	2	1	15	6	6	0	0	0	0	0	0	0	0	0	30	21-30	21
09:00 PM	1	2	6	12	2	1	0	0	0	0	0	0	0	0	24	21-30	18
10:00 PM	0	2	1	5	3	0	0	0	0	0	0	0	0	0	11	26-35	8
11:00 PM	0	0	1	3	1	0	0	0	0	0	0	0	0	0	5	23-32	4
Day Total	41	68	311	468	157	14	4	0	0	0	0	0	0	0	1063	21-30	779
Percent	3.9%	6.4%	29.3%	44%	14.8%	1.3%	0.4%	0%	0%	0%	0%	0%	0%	0%			
AM Peak Volume	10:00 AM	11:00 AM	11:00 AM	7:00 AM	8:00 AM	8:00 AM	12:00 AM	12:00 AM	12:00 AM	12:00 AM	12:00 AM	12:00 AM	12:00 AM	12:00 AM	11:00 AM		
	4	7	36	42	16	2	1	0	0	0	0	0	0	0	82		
PM Peak Volume	5:00 PM	1:00 PM	1:00 PM	5:00 PM	5:00 PM	4:00 PM	4:00 PM	12:00 PM	12:00 PM	12:00 PM	12:00 PM	12:00 PM	12:00 PM	12:00 PM	5:00 PM		
	8	11	27	48	17	3	1	0	0	0	0	0	0	0	108		
<i>Comments:</i>																	

Report generated on 9/22/2023 2:43 PM

SOURCE: Quality Counts, LLC (<http://www.qualitycounts.net>)

Type of report: Tube Count - Speed Data

LOCATION: N Main St btwn Clifford Ct and Illinois St															QC JOB #: 16302723		
SPECIFIC LOCATION:															DIRECTION: SB		
CITY/STATE: Newberg, OR															DATE: Sep 16 2023		
Start Time	1 15	16 20	21 25	26 30	31 35	36 40	41 45	46 50	51 55	56 60	61 65	66 70	71 75	76 999	Total	Pace Speed	Number in Pace
12:00 AM	0	0	2	0	1	0	0	0	0	0	0	0	0	0	3	16-25	2
01:00 AM	0	0	1	0	2	0	0	0	0	0	0	0	0	0	3	26-35	2
02:00 AM	0	0	1	1	0	0	0	0	0	0	0	0	0	0	2	21-30	2
03:00 AM	0	1	0	1	0	0	0	0	0	0	0	0	0	0	2	11-20	1
04:00 AM	0	0	1	0	1	0	0	0	0	0	0	0	0	0	2	16-25	1
05:00 AM	0	1	1	2	1	0	0	0	0	0	0	0	0	0	5	26-35	3
06:00 AM	0	2	5	9	2	0	0	0	0	0	0	0	0	0	18	21-30	14
07:00 AM	0	5	10	24	2	2	0	0	0	0	0	0	0	0	43	21-30	34
08:00 AM	2	1	15	39	13	0	0	0	0	0	0	0	0	0	70	21-30	54
09:00 AM	7	9	19	33	12	2	0	0	0	0	0	0	0	0	82	21-30	52
10:00 AM	5	12	46	63	14	1	0	0	0	0	0	0	0	0	141	21-30	109
11:00 AM	11	16	68	67	7	0	0	0	0	0	0	0	0	0	169	21-30	135
12:00 PM	24	3	38	46	13	0	0	0	0	0	0	0	0	0	124	21-30	84
01:00 PM	1	2	28	40	9	3	0	0	0	0	0	0	0	0	83	21-30	68
02:00 PM	3	2	26	47	9	2	0	0	0	0	0	0	0	0	89	21-30	73
03:00 PM	4	1	8	31	10	0	0	0	0	0	0	0	0	0	54	26-35	41
04:00 PM	4	2	17	38	14	2	0	0	0	0	0	0	0	0	77	21-30	55
05:00 PM	2	3	15	38	6	1	0	0	0	0	0	0	0	0	65	21-30	53
06:00 PM	5	2	25	41	6	1	0	0	0	0	0	0	0	0	80	21-30	66
07:00 PM	0	1	10	14	5	2	0	0	0	0	0	0	0	0	32	21-30	24
08:00 PM	2	1	7	15	0	1	0	0	0	0	0	0	0	0	26	21-30	22
09:00 PM	0	4	8	16	2	2	0	0	0	0	0	0	0	0	32	21-30	24
10:00 PM	1	0	2	7	1	0	0	0	0	0	0	0	0	0	11	21-30	9
11:00 PM	0	0	4	4	0	0	0	0	0	0	0	0	0	0	8	21-30	8
Day Total	71	68	357	576	130	19	0	0	0	0	0	0	0	0	1221	21-30	933
Percent	5.8%	5.6%	29.2%	47.2%	10.6%	1.6%	0%	0%	0%	0%	0%	0%	0%	0%			
AM Peak Volume	11:00 AM	11:00 AM	11:00 AM	11:00 AM	10:00 AM	7:00 AM	12:00 AM	12:00 AM	12:00 AM	12:00 AM	12:00 AM	12:00 AM	12:00 AM	12:00 AM	11:00 AM		
	11	16	68	67	14	2	0	0	0	0	0	0	0	0	169		
PM Peak Volume	12:00 PM	9:00 PM	12:00 PM	2:00 PM	4:00 PM	1:00 PM	12:00 PM	12:00 PM	12:00 PM	12:00 PM	12:00 PM	12:00 PM	12:00 PM	12:00 PM	12:00 PM		
	24	4	38	47	14	3	0	0	0	0	0	0	0	0	124		
<i>Comments:</i>																	

Report generated on 9/22/2023 2:43 PM

SOURCE: Quality Counts, LLC (<http://www.qualitycounts.net>)

Type of report: Tube Count - Speed Data

LOCATION: N Main St btwn Clifford Ct and Illinois St															QC JOB #: 16302723		
SPECIFIC LOCATION:															DIRECTION: SB		
CITY/STATE: Newberg, OR															DATE: Sep 17 2023		
Start Time	1 15	16 20	21 25	26 30	31 35	36 40	41 45	46 50	51 55	56 60	61 65	66 70	71 75	76 999	Total	Pace Speed	Number in Pace
12:00 AM	0	0	3	1	1	0	0	0	0	0	0	0	0	0	5	21-30	4
01:00 AM	0	0	1	2	0	0	0	0	0	0	0	0	0	0	3	21-30	3
02:00 AM	0	0	1	0	0	0	0	0	0	0	0	0	0	0	1	16-25	1
03:00 AM	0	0	0	1	0	0	0	0	0	0	0	0	0	0	1	21-30	1
04:00 AM	0	0	1	2	0	0	0	0	0	0	0	0	0	0	3	21-30	3
05:00 AM	0	1	3	3	0	0	0	0	0	0	0	0	0	0	7	21-30	6
06:00 AM	1	0	8	3	2	0	0	0	0	0	0	0	0	0	14	21-30	11
07:00 AM	2	1	15	20	8	0	0	0	0	0	0	0	0	0	46	21-30	35
08:00 AM	1	2	10	25	3	0	0	0	0	0	0	0	0	0	41	21-30	35
09:00 AM	3	5	22	39	13	1	0	0	0	0	0	0	0	0	83	21-30	61
10:00 AM	0	2	9	42	16	2	0	0	0	0	0	0	0	0	71	26-35	58
11:00 AM	3	5	21	57	15	2	0	0	0	0	0	0	0	0	103	21-30	78
12:00 PM	5	2	17	37	14	0	1	0	0	0	0	0	0	0	76	21-30	54
01:00 PM	2	14	44	59	8	1	0	0	0	0	0	0	0	0	128	21-30	103
02:00 PM	4	5	37	38	14	0	0	0	0	0	0	0	0	0	98	21-30	75
03:00 PM	1	3	18	27	10	0	0	0	0	0	0	0	0	0	59	21-30	45
04:00 PM	1	5	32	37	8	1	0	0	0	0	0	0	0	0	84	21-30	69
05:00 PM	5	5	41	50	13	0	0	0	0	0	0	0	0	0	114	21-30	91
06:00 PM	1	1	14	30	8	0	0	0	0	0	0	0	0	0	54	21-30	44
07:00 PM	0	0	20	21	3	0	0	0	0	0	0	0	0	0	44	21-30	41
08:00 PM	1	3	7	11	2	0	0	0	0	0	0	0	0	0	24	21-30	18
09:00 PM	1	2	5	6	1	0	0	0	0	0	0	0	0	0	15	21-30	11
10:00 PM	0	0	2	4	2	0	0	0	0	0	0	0	0	0	8	26-35	6
11:00 PM	0	1	0	4	0	0	0	0	0	0	0	0	0	0	5	21-30	4
Day Total	31	57	331	519	141	7	1	0	0	0	0	0	0	0	1087	21-30	850
Percent	2.9%	5.2%	30.5%	47.7%	13%	0.6%	0.1%	0%	0%	0%	0%	0%	0%	0%			
AM Peak Volume	9:00 AM	9:00 AM	9:00 AM	11:00 AM	10:00 AM	10:00 AM	12:00 AM	12:00 AM	12:00 AM	12:00 AM	12:00 AM	12:00 AM	12:00 AM	12:00 AM	11:00 AM		
	3	5	22	57	16	2	0	0	0	0	0	0	0	0	103		
PM Peak Volume	12:00 PM	1:00 PM	1:00 PM	1:00 PM	12:00 PM	1:00 PM	12:00 PM	12:00 PM	12:00 PM	12:00 PM	12:00 PM	12:00 PM	12:00 PM	12:00 PM	1:00 PM		
	5	14	44	59	14	1	1	0	0	0	0	0	0	0	128		
<i>Comments:</i>																	

Report generated on 9/22/2023 2:43 PM

SOURCE: Quality Counts, LLC (<http://www.qualitycounts.net>)

Type of report: Tube Count - Speed Data

LOCATION: N Main St btwn Clifford Ct and Illinois St															QC JOB #: 16302723		
SPECIFIC LOCATION:															DIRECTION: SB		
CITY/STATE: Newberg, OR															DATE: Sep 18 2023		
Start Time	1 15	16 20	21 25	26 30	31 35	36 40	41 45	46 50	51 55	56 60	61 65	66 70	71 75	76 999	Total	Pace Speed	Number in Pace
12:00 AM	0	0	1	0	0	0	0	0	0	0	0	0	0	0	1	16-25	1
01:00 AM	0	0	0	2	0	0	0	0	0	0	0	0	0	0	2	21-30	2
02:00 AM	0	0	0	0	0	0	0	0	0	0	0	0	0	0	0	1-10	0
03:00 AM	0	0	0	1	0	0	0	0	0	0	0	0	0	0	1	21-30	1
04:00 AM	0	0	3	4	2	0	0	0	0	0	0	0	0	0	9	21-30	7
05:00 AM	0	1	6	8	2	1	1	0	0	0	0	0	0	0	19	21-30	14
06:00 AM	0	4	13	23	8	0	1	0	0	0	0	0	0	0	49	21-30	36
07:00 AM	7	9	28	36	5	0	0	0	0	0	0	0	0	0	85	21-30	64
08:00 AM	0	3	22	23	11	0	0	0	0	0	0	0	0	0	59	21-30	45
09:00 AM	1	3	14	34	7	1	0	0	0	0	0	0	0	0	60	21-30	48
10:00 AM	0	2	12	30	7	1	0	0	0	0	0	0	0	0	52	21-30	42
11:00 AM	5	1	17	21	7	0	0	0	0	0	0	0	0	0	51	21-30	38
12:00 PM	2	4	14	22	5	0	0	0	0	0	0	0	0	0	47	21-30	36
01:00 PM	1	0	10	24	7	0	0	0	0	0	0	0	0	0	42	21-30	34
02:00 PM	3	3	10	30	10	0	0	0	0	0	0	0	0	0	56	21-30	40
03:00 PM	6	6	17	33	7	0	0	0	0	0	0	0	0	0	69	21-30	50
04:00 PM	8	1	15	43	9	2	0	0	0	0	0	0	0	0	78	21-30	58
05:00 PM	1	3	13	34	13	0	0	0	0	0	0	0	0	0	64	25-34	47
06:00 PM	1	1	28	47	10	0	0	0	0	0	0	0	0	0	87	21-30	75
07:00 PM	0	2	16	17	2	0	0	0	0	0	0	0	0	0	37	21-30	33
08:00 PM	0	2	6	9	5	0	0	0	0	0	0	0	0	0	22	21-30	15
09:00 PM	0	0	5	11	3	3	0	0	0	0	0	0	0	0	22	21-30	16
10:00 PM	0	0	4	2	1	0	0	0	0	0	0	0	0	0	7	21-30	6
11:00 PM	0	0	0	1	3	0	0	0	0	0	0	0	0	0	4	26-35	4
Day Total	35	45	254	455	124	8	2	0	0	0	0	0	0	0	923	21-30	709
Percent	3.8%	4.9%	27.5%	49.3%	13.4%	0.9%	0.2%	0%	0%	0%	0%	0%	0%	0%			
AM Peak Volume	7:00 AM 7	7:00 AM 9	7:00 AM 28	7:00 AM 36	8:00 AM 11	5:00 AM 1	5:00 AM 1	12:00 AM 0	12:00 AM 0	12:00 AM 0	12:00 AM 0	12:00 AM 0	12:00 AM 0	12:00 AM 0	7:00 AM 85		
PM Peak Volume	4:00 PM 8	3:00 PM 6	6:00 PM 28	6:00 PM 47	5:00 PM 13	9:00 PM 3	12:00 PM 0	12:00 PM 0	12:00 PM 0	12:00 PM 0	12:00 PM 0	12:00 PM 0	12:00 PM 0	12:00 PM 0	6:00 PM 87		
<i>Comments:</i>																	

Report generated on 9/22/2023 2:43 PM

SOURCE: Quality Counts, LLC (<http://www.qualitycounts.net>)

SUMMARY - Tube Count - Speed Data

LOCATION: N Main St btwn Clifford Ct and Illinois St														QC JOB #: 16302723			
SPECIFIC LOCATION:														DIRECTION: SB			
CITY/STATE: Newberg, OR														DATE: Sep 12 2023 - Sep 18 2023			
Speed Range	1 15	16 20	21 25	26 30	31 35	36 40	41 45	46 50	51 55	56 60	61 65	66 70	71 75	76 999	Total	Pace Speed	Number in Pace
Grand Total	294	359	2083	3527	1038	93	9	2	1	0	0	0	0	1	7407	21-30	5610
Percent	4%	4.8%	28.1%	47.6%	14%	1.3%	0.1%	0%	0%	0%	0%	0%	0%	0%			
Cumulative Percent	4%	8.8%	36.9%	84.6%	98.6%	99.8%	99.9%	100%	100%	100%	100%	100%	100%	100%			
ADT 1058															85th Percentile: 30 MPH Mean Speed(Average): 26 MPH Median: 26 MPH Mode: 28 MPH		
<i>Comments:</i>																	

Report generated on 9/22/2023 2:43 PM

SOURCE: Quality Counts, LLC (<http://www.qualitycounts.net>)

TRUE DATA TO IMPROVE MOBILITY

Type of report: Tube Count - Speed Data

LOCATION: E Illinois St btwn Main St and Washington St															QC JOB #: 16302724		
SPECIFIC LOCATION:															DIRECTION: EB		
CITY/STATE: Newberg, OR															DATE: Sep 12 2023		
Start Time	1 15	16 20	21 25	26 30	31 35	36 40	41 45	46 50	51 55	56 60	61 65	66 70	71 75	76 999	Total	Pace Speed	Number in Pace
12:00 AM	0	0	0	0	1	0	0	0	0	0	0	0	0	0	1	26-35	1
01:00 AM	0	0	0	1	0	0	0	0	0	0	0	0	0	0	1	21-30	1
02:00 AM	0	1	1	1	1	0	0	0	0	0	0	0	0	0	4	16-25	2
03:00 AM	0	0	0	0	0	0	0	0	0	0	0	0	0	0	0	1-10	0
04:00 AM	1	1	16	22	6	1	0	0	0	0	0	0	0	0	47	21-30	38
05:00 AM	2	1	5	18	7	2	0	0	0	0	0	0	0	0	35	26-35	25
06:00 AM	2	2	18	42	16	0	0	0	0	0	0	0	0	0	80	21-30	60
07:00 AM	2	6	35	70	18	0	1	0	0	0	0	0	0	0	132	21-30	105
08:00 AM	10	2	25	48	25	0	0	0	0	0	0	0	0	0	110	21-30	73
09:00 AM	0	1	16	33	16	2	0	0	0	0	0	0	0	0	68	23-32	49
10:00 AM	2	6	11	29	8	0	0	0	0	0	0	0	0	0	56	21-30	40
11:00 AM	0	0	13	42	14	1	1	0	0	0	0	0	0	0	71	26-35	56
12:00 PM	0	1	20	33	6	2	0	0	0	0	0	0	0	0	62	21-30	53
01:00 PM	4	1	17	34	9	1	0	0	0	0	0	0	0	0	66	21-30	51
02:00 PM	0	1	21	44	9	0	0	0	0	0	0	0	0	0	75	21-30	65
03:00 PM	4	10	43	52	5	1	0	0	0	0	0	0	0	0	115	21-30	95
04:00 PM	6	2	32	48	5	0	0	0	0	0	0	0	0	0	93	21-30	80
05:00 PM	3	1	36	47	8	0	0	0	0	0	0	0	0	0	95	21-30	83
06:00 PM	2	3	37	29	9	0	0	0	0	0	0	0	0	0	80	21-30	66
07:00 PM	1	3	19	25	3	0	0	0	0	0	0	0	0	0	51	21-30	44
08:00 PM	3	1	9	16	3	0	0	0	0	0	0	0	0	0	32	21-30	25
09:00 PM	0	0	7	5	1	0	0	0	0	0	0	0	0	0	13	21-30	12
10:00 PM	0	1	5	2	3	0	0	0	0	0	0	0	0	0	11	21-30	7
11:00 PM	0	0	1	4	0	0	0	0	0	0	0	0	0	0	5	21-30	5
Day Total	42	44	387	645	173	10	2	0	0	0	0	0	0	0	1303	21-30	1032
Percent	3.2%	3.4%	29.7%	49.5%	13.3%	0.8%	0.2%	0%	0%	0%	0%	0%	0%	0%			
AM Peak Volume	8:00 AM 10	7:00 AM 6	7:00 AM 35	7:00 AM 70	8:00 AM 25	5:00 AM 2	7:00 AM 1	12:00 AM 0	12:00 AM 0	12:00 AM 0	12:00 AM 0	12:00 AM 0	12:00 AM 0	12:00 AM 0	7:00 AM 132		
PM Peak Volume	4:00 PM 6	3:00 PM 10	3:00 PM 43	3:00 PM 52	1:00 PM 9	12:00 PM 2	12:00 PM 0	12:00 PM 0	12:00 PM 0	12:00 PM 0	12:00 PM 0	12:00 PM 0	12:00 PM 0	12:00 PM 0	3:00 PM 115		
<i>Comments:</i>																	

Report generated on 9/22/2023 2:43 PM

SOURCE: Quality Counts, LLC (<http://www.qualitycounts.net>)

Type of report: Tube Count - Speed Data

LOCATION: E Illinois St btwn Main St and Washington St															QC JOB #: 16302724		
SPECIFIC LOCATION:															DIRECTION: EB		
CITY/STATE: Newberg, OR															DATE: Sep 13 2023		
Start Time	1 15	16 20	21 25	26 30	31 35	36 40	41 45	46 50	51 55	56 60	61 65	66 70	71 75	76 999	Total	Pace Speed	Number in Pace
12:00 AM	0	0	2	0	2	0	0	0	0	0	0	0	0	0	4	16-25	2
01:00 AM	0	0	0	1	0	0	0	0	0	0	0	0	0	0	1	21-30	1
02:00 AM	0	0	0	1	0	0	0	0	0	0	0	0	0	0	1	21-30	1
03:00 AM	0	0	0	0	0	0	0	0	0	0	0	0	0	0	0	1-10	0
04:00 AM	0	1	17	16	6	1	0	0	0	0	0	0	0	0	41	21-30	33
05:00 AM	2	1	3	25	11	0	0	0	0	0	0	0	0	0	42	26-35	36
06:00 AM	0	3	15	32	10	1	0	0	0	0	0	0	0	0	61	21-30	47
07:00 AM	4	3	28	39	8	2	0	0	0	0	0	0	0	0	84	21-30	67
08:00 AM	4	6	34	54	19	3	0	0	0	0	0	0	0	0	120	21-30	88
09:00 AM	1	3	21	60	16	2	0	0	0	0	0	0	0	0	103	21-30	81
10:00 AM	2	4	11	28	4	0	0	0	0	0	0	0	0	0	49	21-30	39
11:00 AM	0	7	15	37	5	0	0	0	0	0	0	0	0	0	64	21-30	52
12:00 PM	3	3	17	32	6	0	0	0	0	0	0	0	0	0	61	21-30	49
01:00 PM	2	1	15	29	9	0	0	0	0	0	0	0	0	0	56	21-30	44
02:00 PM	3	5	29	45	5	1	0	0	0	0	0	0	0	0	88	21-30	74
03:00 PM	7	0	25	50	14	1	0	0	0	0	0	0	0	0	97	21-30	75
04:00 PM	2	3	19	46	15	0	0	0	0	0	0	0	0	0	85	21-30	65
05:00 PM	2	2	28	55	12	1	0	0	0	0	0	0	0	0	100	21-30	83
06:00 PM	4	1	21	45	10	0	0	0	0	0	0	0	0	0	81	21-30	66
07:00 PM	1	6	25	25	1	1	0	0	0	0	0	0	0	0	59	21-30	50
08:00 PM	2	2	15	11	3	0	0	0	0	0	0	0	0	0	33	21-30	26
09:00 PM	0	2	11	11	3	1	0	0	0	0	0	0	0	0	28	21-30	22
10:00 PM	0	1	3	5	2	0	0	0	0	0	0	0	0	0	11	21-30	8
11:00 PM	0	0	2	7	0	0	0	0	0	0	0	0	0	0	9	21-30	9
Day Total	39	54	356	654	161	14	0	0	0	0	0	0	0	0	1278	21-30	1010
Percent	3.1%	4.2%	27.9%	51.2%	12.6%	1.1%	0%	0%	0%	0%	0%	0%	0%	0%			
AM Peak Volume	7:00 AM 4	11:00 AM 7	8:00 AM 34	9:00 AM 60	8:00 AM 19	8:00 AM 3	12:00 AM 0	12:00 AM 0	12:00 AM 0	12:00 AM 0	12:00 AM 0	12:00 AM 0	12:00 AM 0	12:00 AM 0	8:00 AM 120		
PM Peak Volume	3:00 PM 7	7:00 PM 6	2:00 PM 29	5:00 PM 55	4:00 PM 15	2:00 PM 1	12:00 PM 0	12:00 PM 0	12:00 PM 0	12:00 PM 0	12:00 PM 0	12:00 PM 0	12:00 PM 0	12:00 PM 0	5:00 PM 100		
<i>Comments:</i>																	

Report generated on 9/22/2023 2:43 PM

SOURCE: Quality Counts, LLC (<http://www.qualitycounts.net>)

Type of report: Tube Count - Speed Data

LOCATION: E Illinois St btwn Main St and Washington St															QC JOB #: 16302724		
SPECIFIC LOCATION:															DIRECTION: EB		
CITY/STATE: Newberg, OR															DATE: Sep 14 2023		
Start Time	1 15	16 20	21 25	26 30	31 35	36 40	41 45	46 50	51 55	56 60	61 65	66 70	71 75	76 999	Total	Pace Speed	Number in Pace
12:00 AM	0	0	1	1	0	0	0	0	0	0	0	0	0	0	2	21-30	2
01:00 AM	0	0	0	1	0	0	0	0	0	0	0	0	0	0	1	21-30	1
02:00 AM	0	0	0	0	0	0	0	0	0	0	0	0	0	0	0	1-10	0
03:00 AM	0	1	1	0	1	0	0	0	0	0	0	0	0	0	3	16-25	2
04:00 AM	0	1	17	19	9	1	0	0	0	0	0	0	0	0	47	21-30	36
05:00 AM	2	0	5	20	9	2	0	0	0	0	0	0	0	0	38	26-35	29
06:00 AM	1	6	17	37	9	1	0	0	0	0	0	0	0	0	71	21-30	54
07:00 AM	3	11	39	57	14	0	0	0	0	0	0	0	0	0	124	21-30	96
08:00 AM	6	2	31	48	19	1	1	0	0	0	0	0	0	0	108	21-30	79
09:00 AM	0	3	17	29	9	2	1	0	0	0	0	0	0	0	61	21-30	46
10:00 AM	2	1	16	29	12	0	0	0	0	0	0	0	0	0	60	21-30	45
11:00 AM	2	4	12	35	9	0	0	0	0	0	0	0	0	0	62	21-30	47
12:00 PM	1	2	24	31	10	2	0	0	0	0	0	0	0	0	70	21-30	55
01:00 PM	3	0	19	43	12	1	0	0	0	0	0	0	0	0	78	21-30	62
02:00 PM	1	4	19	43	17	1	0	0	0	0	0	0	0	0	85	21-30	62
03:00 PM	2	4	22	41	10	1	0	0	0	0	0	0	0	0	80	21-30	63
04:00 PM	0	3	26	45	16	2	0	0	0	0	0	0	0	0	92	21-30	71
05:00 PM	3	2	29	51	7	0	0	0	0	0	0	0	0	0	92	21-30	80
06:00 PM	4	2	29	44	14	1	1	0	0	0	0	0	0	0	95	21-30	73
07:00 PM	1	2	22	34	3	0	0	0	0	0	0	0	0	0	62	21-30	56
08:00 PM	4	3	9	23	7	0	0	0	0	0	0	0	0	0	46	21-30	32
09:00 PM	0	0	16	8	1	0	0	0	0	0	0	0	0	0	25	21-30	24
10:00 PM	0	1	4	4	0	0	0	0	0	0	0	0	0	0	9	21-30	8
11:00 PM	0	0	2	5	0	0	0	0	0	0	0	0	0	0	7	21-30	7
Day Total	35	52	377	648	188	15	3	0	0	0	0	0	0	0	1318	21-30	1025
Percent	2.7%	3.9%	28.6%	49.2%	14.3%	1.1%	0.2%	0%	0%	0%	0%	0%	0%	0%			
AM Peak Volume	8:00 AM	7:00 AM	7:00 AM	7:00 AM	8:00 AM	5:00 AM	8:00 AM	12:00 AM	12:00 AM	12:00 AM	12:00 AM	12:00 AM	12:00 AM	12:00 AM	12:00 AM	7:00 AM	
	6	11	39	57	19	2	1	0	0	0	0	0	0	0	124		
PM Peak Volume	6:00 PM	2:00 PM	5:00 PM	5:00 PM	2:00 PM	12:00 PM	6:00 PM	12:00 PM	12:00 PM	12:00 PM	12:00 PM	12:00 PM	12:00 PM	12:00 PM	12:00 PM	6:00 PM	
	4	4	29	51	17	2	1	0	0	0	0	0	0	0	95		
<i>Comments:</i>																	

Report generated on 9/22/2023 2:43 PM

SOURCE: Quality Counts, LLC (<http://www.qualitycounts.net>)

Type of report: Tube Count - Speed Data

LOCATION: E Illinois St btwn Main St and Washington St															QC JOB #: 16302724		
SPECIFIC LOCATION:															DIRECTION: EB		
CITY/STATE: Newberg, OR															DATE: Sep 15 2023		
Start Time	1 15	16 20	21 25	26 30	31 35	36 40	41 45	46 50	51 55	56 60	61 65	66 70	71 75	76 999	Total	Pace Speed	Number in Pace
12:00 AM	0	0	1	3	0	1	0	0	0	0	0	0	0	0	5	21-30	4
01:00 AM	0	0	1	0	0	0	0	0	0	0	0	0	0	0	1	16-25	1
02:00 AM	0	0	0	3	0	0	0	0	0	0	0	0	0	0	3	21-30	3
03:00 AM	0	0	0	3	0	0	0	0	0	0	0	0	0	0	3	21-30	3
04:00 AM	0	1	2	7	1	0	0	0	0	0	0	0	0	0	11	21-30	9
05:00 AM	1	0	1	16	4	0	0	0	0	0	0	0	0	0	22	26-35	20
06:00 AM	3	2	20	39	11	0	1	0	0	0	0	0	0	0	76	21-30	59
07:00 AM	2	7	33	59	16	1	0	0	0	0	0	0	0	0	118	21-30	92
08:00 AM	3	7	24	53	19	2	0	0	0	0	0	0	0	0	108	21-30	77
09:00 AM	4	3	20	39	9	1	0	0	0	0	0	0	0	0	76	21-30	59
10:00 AM	5	6	18	24	4	0	0	0	0	0	0	0	0	0	57	21-30	42
11:00 AM	3	3	26	38	1	1	0	0	0	0	0	0	0	0	72	21-30	64
12:00 PM	0	2	14	25	10	0	1	0	0	0	0	0	0	0	52	21-30	39
01:00 PM	3	4	30	35	6	1	0	0	0	0	0	0	0	0	79	21-30	65
02:00 PM	1	3	28	40	11	1	0	0	0	0	0	0	0	0	84	21-30	68
03:00 PM	3	3	15	63	15	2	0	0	0	0	0	0	0	0	101	21-30	78
04:00 PM	0	0	25	44	17	0	0	0	0	0	0	0	0	0	86	21-30	69
05:00 PM	4	1	21	49	18	0	0	0	0	0	0	0	0	0	93	21-30	70
06:00 PM	3	1	17	38	14	0	0	0	0	0	0	0	0	0	73	21-30	55
07:00 PM	0	6	10	24	3	0	0	0	0	0	0	0	0	0	43	21-30	34
08:00 PM	1	0	6	23	2	1	0	0	0	0	0	0	0	0	33	21-30	29
09:00 PM	1	1	12	9	4	0	0	0	0	0	0	0	0	0	27	21-30	21
10:00 PM	0	0	8	5	2	0	0	0	0	0	0	0	0	0	15	21-30	13
11:00 PM	1	0	3	6	0	0	0	0	0	0	0	0	0	0	10	21-30	9
Day Total	38	50	335	645	167	11	2	0	0	0	0	0	0	0	1248	21-30	980
Percent	3%	4%	26.8%	51.7%	13.4%	0.9%	0.2%	0%	0%	0%	0%	0%	0%	0%			
AM Peak Volume	10:00 AM	7:00 AM	7:00 AM	7:00 AM	8:00 AM	8:00 AM	6:00 AM	12:00 AM	12:00 AM	12:00 AM	12:00 AM	12:00 AM	12:00 AM	12:00 AM	7:00 AM		
	5	7	33	59	19	2	1	0	0	0	0	0	0	0	118		
PM Peak Volume	5:00 PM	7:00 PM	1:00 PM	3:00 PM	5:00 PM	3:00 PM	12:00 PM	12:00 PM	12:00 PM	12:00 PM	12:00 PM	12:00 PM	12:00 PM	12:00 PM	3:00 PM		
	4	6	30	63	18	2	1	0	0	0	0	0	0	0	101		

Report generated on 9/22/2023 2:43 PM

SOURCE: Quality Counts, LLC (<http://www.qualitycounts.net>)

Type of report: Tube Count - Speed Data

LOCATION: E Illinois St btwn Main St and Washington St															QC JOB #: 16302724		
SPECIFIC LOCATION:															DIRECTION: EB		
CITY/STATE: Newberg, OR															DATE: Sep 16 2023		
Start Time	1 15	16 20	21 25	26 30	31 35	36 40	41 45	46 50	51 55	56 60	61 65	66 70	71 75	76 999	Total	Pace Speed	Number in Pace
12:00 AM	0	0	2	1	1	0	0	0	0	0	0	0	0	0	4	21-30	3
01:00 AM	0	0	0	1	0	0	0	0	0	0	0	0	0	0	1	21-30	1
02:00 AM	0	1	1	1	0	0	0	0	0	0	0	0	0	0	3	16-25	2
03:00 AM	0	0	0	2	0	0	0	0	0	0	0	0	0	0	2	21-30	2
04:00 AM	0	0	3	4	0	1	0	0	0	0	0	0	0	0	8	21-30	7
05:00 AM	1	1	0	4	0	0	0	0	0	0	0	0	0	0	6	21-30	4
06:00 AM	1	0	3	7	0	1	0	0	0	0	0	0	0	0	12	21-30	10
07:00 AM	1	1	7	19	0	0	0	0	0	0	0	0	0	0	28	21-30	26
08:00 AM	2	2	17	31	6	1	0	0	0	0	0	0	0	0	59	21-30	48
09:00 AM	3	10	23	23	10	0	0	0	0	0	0	0	0	0	69	21-30	46
10:00 AM	2	2	27	49	14	0	0	0	0	0	0	0	0	0	94	21-30	76
11:00 AM	5	3	31	40	8	3	0	0	0	0	0	0	0	0	90	21-30	71
12:00 PM	2	3	24	46	14	3	0	0	0	0	0	0	0	0	92	21-30	70
01:00 PM	3	3	16	37	8	0	0	0	0	0	0	0	0	0	67	21-30	53
02:00 PM	5	2	19	45	10	0	1	0	0	0	0	0	0	0	82	21-30	64
03:00 PM	1	3	20	35	9	0	0	0	0	0	0	0	0	0	68	21-30	55
04:00 PM	2	1	16	37	11	1	0	0	0	0	0	0	0	0	68	21-30	53
05:00 PM	2	6	12	39	10	1	0	0	0	0	0	0	0	0	70	21-30	51
06:00 PM	3	4	22	29	11	0	0	0	0	0	0	0	0	0	69	21-30	51
07:00 PM	0	3	13	19	3	0	0	0	0	0	0	0	0	0	38	21-30	32
08:00 PM	1	0	15	14	4	0	0	0	0	0	0	0	0	0	34	21-30	29
09:00 PM	0	0	12	10	0	0	0	0	0	0	0	0	0	0	22	21-30	22
10:00 PM	0	0	9	7	0	1	0	0	0	0	0	0	0	0	17	21-30	16
11:00 PM	1	1	10	4	1	0	0	0	0	0	0	0	0	0	17	21-30	14
Day Total	35	46	302	504	120	12	1	0	0	0	0	0	0	0	1020	21-30	806
Percent	3.4%	4.5%	29.6%	49.4%	11.8%	1.2%	0.1%	0%	0%	0%	0%	0%	0%	0%			
AM Peak Volume	11:00 AM	9:00 AM	11:00 AM	10:00 AM	10:00 AM	11:00 AM	12:00 AM	12:00 AM	12:00 AM	12:00 AM	12:00 AM	12:00 AM	12:00 AM	12:00 AM	10:00 AM		
	5	10	31	49	14	3	0	0	0	0	0	0	0	0	94		
PM Peak Volume	2:00 PM	5:00 PM	12:00 PM	12:00 PM	12:00 PM	12:00 PM	2:00 PM	12:00 PM	12:00 PM	12:00 PM	12:00 PM	12:00 PM	12:00 PM	12:00 PM	12:00 PM		
	5	6	24	46	14	3	1	0	0	0	0	0	0	0	92		
<i>Comments:</i>																	

Report generated on 9/22/2023 2:43 PM

SOURCE: Quality Counts, LLC (<http://www.qualitycounts.net>)

Type of report: Tube Count - Speed Data

LOCATION: E Illinois St btwn Main St and Washington St															QC JOB #: 16302724			
SPECIFIC LOCATION:															DIRECTION: EB			
CITY/STATE: Newberg, OR															DATE: Sep 17 2023			
Start Time	1 15	16 20	21 25	26 30	31 35	36 40	41 45	46 50	51 55	56 60	61 65	66 70	71 75	76 999	Total	Pace Speed	Number in Pace	
12:00 AM	1	1	3	5	0	0	0	0	0	0	0	0	0	0	10	21-30	8	
01:00 AM	0	0	2	4	0	0	0	0	0	0	0	0	0	0	6	21-30	6	
02:00 AM	0	0	1	1	1	0	0	0	0	0	0	0	0	0	3	21-30	2	
03:00 AM	0	0	0	1	0	0	0	0	0	0	0	0	0	0	1	21-30	1	
04:00 AM	0	0	4	4	1	0	0	0	0	0	0	0	0	0	9	21-30	8	
05:00 AM	0	0	4	3	1	0	0	0	0	0	0	0	0	0	8	21-30	7	
06:00 AM	0	5	2	6	0	0	0	0	0	0	0	0	0	0	13	21-30	8	
07:00 AM	1	3	8	10	5	0	0	0	0	0	0	0	0	0	27	21-30	18	
08:00 AM	0	1	19	15	3	0	0	0	0	0	0	0	0	0	38	21-30	34	
09:00 AM	3	1	19	35	9	0	0	0	0	0	0	0	0	0	67	21-30	54	
10:00 AM	5	2	15	38	5	1	0	0	0	0	0	0	0	0	66	21-30	53	
11:00 AM	3	2	15	41	13	0	0	0	0	0	0	0	0	0	74	21-30	56	
12:00 PM	4	3	28	46	11	1	0	0	0	0	0	0	0	0	93	21-30	74	
01:00 PM	8	1	28	42	10	2	0	0	0	0	0	0	0	0	91	21-30	70	
02:00 PM	4	5	23	30	6	0	1	1	0	0	0	0	0	0	70	21-30	53	
03:00 PM	6	2	27	28	7	1	0	0	0	0	0	0	0	0	71	21-30	55	
04:00 PM	2	5	23	30	2	0	0	0	0	0	0	0	0	0	62	21-30	53	
05:00 PM	3	2	29	38	9	0	0	0	0	0	0	0	0	0	81	21-30	67	
06:00 PM	2	4	24	22	4	0	0	0	0	0	0	0	0	0	56	21-30	46	
07:00 PM	3	4	15	14	2	0	0	0	0	0	0	0	0	0	38	21-30	29	
08:00 PM	0	0	14	15	2	0	0	0	0	0	0	0	0	0	31	21-30	29	
09:00 PM	0	2	4	12	3	0	0	0	0	0	0	0	0	0	21	21-30	16	
10:00 PM	0	0	2	2	2	0	0	0	0	0	0	0	0	0	6	21-30	4	
11:00 PM	0	0	1	6	0	0	0	0	0	0	0	0	0	0	7	21-30	7	
Day Total	45	43	310	448	96	5	1	1	0	0	0	0	0	0	949	21-30	758	
Percent	4.7%	4.5%	32.7%	47.2%	10.1%	0.5%	0.1%	0.1%	0%	0%	0%	0%	0%	0%				
AM Peak Volume	10:00 AM	6:00 AM	8:00 AM	11:00 AM	11:00 AM	10:00 AM	12:00 AM	12:00 AM	12:00 AM	12:00 AM	12:00 AM	12:00 AM	12:00 AM	12:00 AM	12:00 AM	11:00 AM		
	5	5	19	41	13	1	0	0	0	0	0	0	0	0	74			
PM Peak Volume	1:00 PM	2:00 PM	5:00 PM	12:00 PM	12:00 PM	1:00 PM	2:00 PM	2:00 PM	12:00 PM	12:00 PM	12:00 PM	12:00 PM	12:00 PM	12:00 PM	12:00 PM			
	8	5	29	46	11	2	1	1	0	0	0	0	0	0	93			

Report generated on 9/22/2023 2:43 PM

SOURCE: Quality Counts, LLC (<http://www.qualitycounts.net>)

Type of report: Tube Count - Speed Data

LOCATION: E Illinois St btwn Main St and Washington St															QC JOB #: 16302724		
SPECIFIC LOCATION:															DIRECTION: EB		
CITY/STATE: Newberg, OR															DATE: Sep 18 2023		
Start Time	1 15	16 20	21 25	26 30	31 35	36 40	41 45	46 50	51 55	56 60	61 65	66 70	71 75	76 999	Total	Pace Speed	Number in Pace
12:00 AM	0	0	1	4	1	0	0	0	0	0	0	0	0	0	6	25-34	5
01:00 AM	0	0	1	1	0	0	0	0	0	0	0	0	0	0	2	21-30	2
02:00 AM	0	0	1	1	0	0	0	0	0	0	0	0	0	0	2	21-30	2
03:00 AM	0	1	0	0	0	0	0	0	0	0	0	0	0	0	1	11-20	1
04:00 AM	1	2	17	21	6	0	0	0	0	0	0	0	0	0	47	21-30	38
05:00 AM	0	0	7	18	12	0	0	0	0	0	0	0	0	0	37	26-35	30
06:00 AM	0	3	24	33	5	1	0	0	0	0	0	0	0	0	66	21-30	57
07:00 AM	3	7	52	60	11	0	0	0	0	0	0	0	0	0	133	21-30	112
08:00 AM	5	11	51	34	9	0	0	0	0	0	0	0	0	0	110	21-30	85
09:00 AM	2	6	28	24	4	0	0	0	0	0	0	0	0	0	64	21-30	52
10:00 AM	2	4	41	16	2	0	0	0	0	0	0	0	0	0	65	21-30	57
11:00 AM	5	10	28	17	4	1	0	0	0	0	0	0	0	0	65	21-30	45
12:00 PM	5	8	21	27	10	0	0	0	0	0	0	0	0	0	71	21-30	48
01:00 PM	2	7	29	30	3	1	0	0	0	0	0	0	0	0	72	21-30	59
02:00 PM	0	6	23	46	8	0	0	0	0	0	0	0	0	0	83	21-30	69
03:00 PM	1	3	30	36	16	1	1	0	0	0	0	0	0	0	88	21-30	66
04:00 PM	5	3	21	52	14	1	0	0	0	0	0	0	0	0	96	21-30	73
05:00 PM	1	1	20	45	7	1	0	0	0	0	0	0	0	0	75	21-30	65
06:00 PM	0	2	26	38	5	3	2	0	0	0	0	0	0	0	76	21-30	64
07:00 PM	4	1	16	19	6	1	0	0	0	0	0	0	0	0	47	21-30	35
08:00 PM	1	1	12	12	1	0	0	0	0	0	0	0	0	0	27	21-30	24
09:00 PM	1	1	6	11	1	0	0	0	0	0	0	0	0	0	20	21-30	17
10:00 PM	3	0	3	4	1	0	0	0	0	0	0	0	0	0	11	21-30	7
11:00 PM	0	0	1	1	0	0	0	0	0	0	0	0	0	0	2	21-30	2
Day Total	41	77	459	550	126	10	3	0	0	0	0	0	0	0	1266	21-30	1009
Percent	3.2%	6.1%	36.3%	43.4%	10%	0.8%	0.2%	0%	0%	0%	0%	0%	0%	0%			
AM Peak Volume	8:00 AM 5	8:00 AM 11	7:00 AM 52	7:00 AM 60	5:00 AM 12	6:00 AM 1	12:00 AM 0	12:00 AM 0	12:00 AM 0	12:00 AM 0	12:00 AM 0	12:00 AM 0	12:00 AM 0	12:00 AM 0	7:00 AM 133		
PM Peak Volume	12:00 PM 5	12:00 PM 8	3:00 PM 30	4:00 PM 52	3:00 PM 16	6:00 PM 3	6:00 PM 2	12:00 PM 0	12:00 PM 0	12:00 PM 0	12:00 PM 0	12:00 PM 0	12:00 PM 0	12:00 PM 0	4:00 PM 96		
<i>Comments:</i>																	

Report generated on 9/22/2023 2:43 PM

SOURCE: Quality Counts, LLC (<http://www.qualitycounts.net>)

LOCATION: E Illinois St btwn Main St and Washington St														QC JOB #: 16302724			
SPECIFIC LOCATION:														DIRECTION: EB			
CITY/STATE: Newberg, OR														DATE: Sep 12 2023 - Sep 18 2023			
Speed Range	1 15	16 20	21 25	26 30	31 35	36 40	41 45	46 50	51 55	56 60	61 65	66 70	71 75	76 999	Total	Pace Speed	Number in Pace
Grand Total	275	366	2526	4094	1031	77	12	1	0	0	0	0	0	0	8382	21-30	6620
Percent	3.3%	4.4%	30.1%	48.8%	12.3%	0.9%	0.1%	0%	0%	0%	0%	0%	0%	0%			
Cumulative Percent	3.3%	7.6%	37.8%	86.6%	98.9%	99.8%	100%	100%	100%	100%	100%	100%	100%	100%			
ADT 1197															85th Percentile: 29 MPH Mean Speed(Average): 26 MPH Median: 26 MPH Mode: 28 MPH		
<i>Comments:</i>																	

Report generated on 9/22/2023 2:43 PM

SOURCE: Quality Counts, LLC (<http://www.qualitycounts.net>)

TRUE DATA TO IMPROVE MOBILITY

Type of report: Tube Count - Speed Data

LOCATION: E Illinois St btwn Main St and Washington St															QC JOB #: 16302724		
SPECIFIC LOCATION:															DIRECTION: WB		
CITY/STATE: Newberg, OR															DATE: Sep 12 2023		
Start Time	15	20	25	30	35	40	45	50	55	60	65	70	75	999	Total	Pace Speed	Number in Pace
12:00 AM	0	0	1	0	0	0	0	0	0	0	0	0	0	0	1	16-25	1
01:00 AM	0	1	2	1	2	0	0	0	0	0	0	0	0	0	6	21-30	3
02:00 AM	0	1	1	3	0	0	0	0	0	0	0	0	0	0	5	21-30	4
03:00 AM	0	0	0	0	0	0	0	0	0	0	0	0	0	0	0	1-10	0
04:00 AM	0	0	1	0	0	0	0	0	0	0	0	0	0	0	1	16-25	1
05:00 AM	0	0	1	7	2	0	0	0	0	0	0	0	0	0	10	26-35	9
06:00 AM	2	1	11	14	4	0	0	0	0	0	0	0	0	0	32	21-30	25
07:00 AM	2	6	13	29	6	1	0	0	0	0	0	0	0	0	57	21-30	42
08:00 AM	1	0	6	44	5	2	0	0	0	0	0	0	0	0	58	21-30	50
09:00 AM	4	0	18	32	7	1	0	0	0	0	0	0	0	0	62	21-30	50
10:00 AM	1	3	14	28	6	1	0	0	0	0	0	0	0	0	53	21-30	42
11:00 AM	0	0	15	30	13	3	0	0	0	0	0	0	0	0	61	21-30	45
12:00 PM	1	4	22	29	8	1	0	0	0	0	0	0	0	0	65	21-30	51
01:00 PM	3	4	17	36	8	2	0	0	0	0	0	0	0	0	70	21-30	53
02:00 PM	3	3	20	56	9	0	0	0	0	0	0	0	0	0	91	21-30	76
03:00 PM	12	13	36	44	8	1	0	0	0	0	0	0	0	0	114	21-30	80
04:00 PM	4	6	42	56	8	0	0	0	0	0	0	0	0	0	116	21-30	98
05:00 PM	5	12	54	47	12	1	0	0	0	0	0	0	0	0	131	21-30	101
06:00 PM	4	3	23	45	16	0	0	0	0	0	0	0	0	0	91	21-30	68
07:00 PM	0	3	24	35	5	0	0	0	0	0	0	0	0	0	67	21-30	59
08:00 PM	2	1	21	24	4	0	0	0	0	0	0	0	0	0	52	21-30	45
09:00 PM	1	0	7	12	3	0	0	0	0	0	0	0	0	0	23	21-30	19
10:00 PM	0	0	8	11	0	0	0	0	0	0	0	0	0	0	19	21-30	19
11:00 PM	0	0	0	3	1	0	0	0	0	0	0	0	0	0	4	26-35	4
Day Total	45	61	357	586	127	13	0	0	0	0	0	0	0	0	1189	21-30	943
Percent	3.8%	5.1%	30%	49.3%	10.7%	1.1%	0%	0%	0%	0%	0%	0%	0%	0%			
AM Peak Volume	9:00 AM	7:00 AM	9:00 AM	8:00 AM	11:00 AM	11:00 AM	12:00 AM	12:00 AM	12:00 AM	12:00 AM	12:00 AM	12:00 AM	12:00 AM	12:00 AM	9:00 AM		
	4	6	18	44	13	3	0	0	0	0	0	0	0	0	62		
PM Peak Volume	3:00 PM	3:00 PM	5:00 PM	2:00 PM	6:00 PM	1:00 PM	12:00 PM	12:00 PM	12:00 PM	12:00 PM	12:00 PM	12:00 PM	12:00 PM	12:00 PM	5:00 PM		
	12	13	54	56	16	2	0	0	0	0	0	0	0	0	131		
<i>Comments:</i>																	

Report generated on 9/22/2023 2:43 PM

SOURCE: Quality Counts, LLC (<http://www.qualitycounts.net>)

Type of report: Tube Count - Speed Data

LOCATION: E Illinois St btwn Main St and Washington St															QC JOB #: 16302724		
SPECIFIC LOCATION:															DIRECTION: WB		
CITY/STATE: Newberg, OR															DATE: Sep 13 2023		
Start Time	1 15	16 20	21 25	26 30	31 35	36 40	41 45	46 50	51 55	56 60	61 65	66 70	71 75	76 999	Total	Pace Speed	Number in Pace
12:00 AM	0	0	4	2	0	0	0	0	0	0	0	0	0	0	6	21-30	6
01:00 AM	0	0	2	1	0	0	0	0	0	0	0	0	0	0	3	21-30	3
02:00 AM	0	0	0	3	1	0	0	0	0	0	0	0	0	0	4	26-35	4
03:00 AM	0	0	0	1	0	0	0	0	0	0	0	0	0	0	1	21-30	1
04:00 AM	0	0	0	2	1	0	0	0	0	0	0	0	0	0	3	26-35	3
05:00 AM	0	0	3	9	0	0	0	0	0	0	0	0	0	0	12	21-30	12
06:00 AM	0	0	9	13	5	0	0	0	0	0	0	0	0	0	27	21-30	22
07:00 AM	0	1	13	24	14	2	0	0	0	0	0	0	0	0	54	26-35	38
08:00 AM	1	0	20	41	9	1	0	0	0	0	0	0	0	0	72	21-30	61
09:00 AM	2	0	16	48	20	1	0	0	0	0	0	0	0	0	87	26-35	68
10:00 AM	1	1	26	24	11	0	0	0	0	0	0	0	0	0	63	21-30	50
11:00 AM	1	2	26	34	16	1	0	0	0	0	0	0	0	0	80	21-30	60
12:00 PM	1	2	16	35	16	2	0	0	0	0	0	0	0	0	72	25-34	51
01:00 PM	1	2	15	41	6	0	0	0	0	0	0	0	0	0	65	21-30	56
02:00 PM	3	1	18	49	10	1	0	0	0	0	0	0	0	0	82	21-30	67
03:00 PM	7	10	38	75	19	0	0	0	0	0	0	0	0	0	149	21-30	113
04:00 PM	5	4	33	59	22	3	0	0	0	0	0	0	0	0	126	21-30	92
05:00 PM	2	2	25	53	23	0	0	0	0	0	0	0	0	0	105	21-30	78
06:00 PM	5	0	17	45	18	1	0	0	0	0	0	0	0	0	86	26-35	63
07:00 PM	2	7	20	24	7	2	0	0	0	0	0	0	0	0	62	21-30	44
08:00 PM	1	1	18	21	5	0	0	0	0	0	0	0	0	0	46	21-30	39
09:00 PM	2	0	5	10	6	0	0	0	0	0	0	0	0	0	23	26-35	16
10:00 PM	0	0	5	8	4	0	0	0	0	0	0	0	0	0	17	21-30	13
11:00 PM	0	0	3	4	2	0	0	0	0	0	0	0	0	0	9	21-30	7
Day Total	34	33	332	626	215	14	0	0	0	0	0	0	0	0	1254	21-30	958
Percent	2.7%	2.6%	26.5%	49.9%	17.1%	1.1%	0%	0%	0%	0%	0%	0%	0%	0%			
AM Peak Volume	9:00 AM	11:00 AM	10:00 AM	9:00 AM	9:00 AM	7:00 AM	12:00 AM	12:00 AM	12:00 AM	12:00 AM	12:00 AM	12:00 AM	12:00 AM	12:00 AM	9:00 AM		
	2	2	26	48	20	2	0	0	0	0	0	0	0	0	87		
PM Peak Volume	3:00 PM	3:00 PM	3:00 PM	3:00 PM	5:00 PM	4:00 PM	12:00 PM	12:00 PM	12:00 PM	12:00 PM	12:00 PM	12:00 PM	12:00 PM	12:00 PM	3:00 PM		
	7	10	38	75	23	3	0	0	0	0	0	0	0	0	149		
<i>Comments:</i>																	

Report generated on 9/22/2023 2:43 PM

SOURCE: Quality Counts, LLC (<http://www.qualitycounts.net>)

Type of report: Tube Count - Speed Data

LOCATION: E Illinois St btwn Main St and Washington St															QC JOB #: 16302724		
SPECIFIC LOCATION:															DIRECTION: WB		
CITY/STATE: Newberg, OR															DATE: Sep 14 2023		
Start Time	1 15	16 20	21 25	26 30	31 35	36 40	41 45	46 50	51 55	56 60	61 65	66 70	71 75	76 999	Total	Pace Speed	Number in Pace
12:00 AM	0	0	1	2	1	0	0	0	0	0	0	0	0	0	4	26-35	3
01:00 AM	0	0	1	1	0	1	0	0	0	0	0	0	0	0	3	21-30	2
02:00 AM	0	0	1	3	0	0	0	0	0	0	0	0	0	0	4	21-30	4
03:00 AM	0	0	0	1	0	0	0	0	0	0	0	0	0	0	1	21-30	1
04:00 AM	0	0	0	1	0	0	0	0	0	0	0	0	0	0	1	21-30	1
05:00 AM	2	0	1	9	2	0	0	0	0	0	0	0	0	0	14	26-35	11
06:00 AM	0	2	14	15	4	0	1	0	0	0	0	0	0	0	36	21-30	29
07:00 AM	1	1	17	29	12	1	0	0	0	0	0	0	0	0	61	21-30	46
08:00 AM	2	1	25	38	6	2	0	0	0	0	0	0	0	0	74	21-30	63
09:00 AM	2	0	15	24	8	0	0	0	0	0	0	0	0	0	49	21-30	39
10:00 AM	0	2	17	26	12	2	0	0	0	0	0	0	0	0	59	21-30	43
11:00 AM	0	1	12	43	10	2	0	0	0	0	0	0	0	0	68	21-30	55
12:00 PM	9	0	19	38	19	1	0	0	0	0	0	0	0	0	86	21-30	57
01:00 PM	3	3	21	34	7	0	0	0	0	0	0	0	0	0	68	21-30	55
02:00 PM	0	2	24	59	10	0	0	0	0	0	0	0	0	0	95	21-30	83
03:00 PM	7	4	35	60	19	0	0	0	0	0	0	0	0	0	125	21-30	95
04:00 PM	4	5	27	73	10	3	0	0	0	0	0	0	0	0	122	21-30	100
05:00 PM	11	5	33	59	21	1	0	0	0	0	0	0	0	0	130	21-30	92
06:00 PM	1	4	27	48	13	2	0	0	0	0	0	0	0	0	95	21-30	75
07:00 PM	3	0	20	32	5	1	0	0	0	0	0	0	0	0	61	21-30	52
08:00 PM	5	3	16	30	3	0	0	0	0	0	0	0	0	0	57	21-30	46
09:00 PM	1	1	12	15	3	0	0	0	0	0	0	0	0	0	32	21-30	27
10:00 PM	0	0	4	7	5	1	0	0	0	0	0	0	0	0	17	26-35	12
11:00 PM	0	0	3	6	3	0	0	0	0	0	0	0	0	0	12	21-30	9
Day Total	51	34	345	653	173	17	1	0	0	0	0	0	0	0	1274	21-30	998
Percent	4%	2.7%	27.1%	51.3%	13.6%	1.3%	0.1%	0%	0%	0%	0%	0%	0%	0%			
AM Peak Volume	5:00 AM	6:00 AM	8:00 AM	11:00 AM	7:00 AM	8:00 AM	6:00 AM	12:00 AM	12:00 AM	12:00 AM	12:00 AM	12:00 AM	12:00 AM	12:00 AM	12:00 AM	8:00 AM	
	2	2	25	43	12	2	1	0	0	0	0	0	0	0	0	74	
PM Peak Volume	5:00 PM	4:00 PM	3:00 PM	4:00 PM	5:00 PM	4:00 PM	12:00 PM	12:00 PM	12:00 PM	12:00 PM	12:00 PM	12:00 PM	12:00 PM	12:00 PM	12:00 PM	5:00 PM	
	11	5	35	73	21	3	0	0	0	0	0	0	0	0	0	130	

Report generated on 9/22/2023 2:43 PM

SOURCE: Quality Counts, LLC (<http://www.qualitycounts.net>)

Type of report: Tube Count - Speed Data

LOCATION: E Illinois St btwn Main St and Washington St															QC JOB #: 16302724			
SPECIFIC LOCATION:															DIRECTION: WB			
CITY/STATE: Newberg, OR															DATE: Sep 15 2023			
Start Time	1 15	16 20	21 25	26 30	31 35	36 40	41 45	46 50	51 55	56 60	61 65	66 70	71 75	76 999	Total	Pace Speed	Number in Pace	
12:00 AM	0	0	0	2	1	0	0	0	0	0	0	0	0	0	3	26-35	3	
01:00 AM	0	0	0	1	1	0	0	0	0	0	0	0	0	0	2	26-35	2	
02:00 AM	0	0	0	2	1	0	0	0	0	0	0	0	0	0	3	26-35	3	
03:00 AM	0	0	0	0	0	0	0	0	0	0	0	0	0	0	0	1-10	0	
04:00 AM	0	0	0	0	0	0	0	0	0	0	0	0	0	0	0	1-10	0	
05:00 AM	0	0	3	3	1	0	0	0	0	0	0	0	0	0	7	21-30	6	
06:00 AM	2	2	7	14	5	0	0	0	0	0	0	0	0	0	30	21-30	21	
07:00 AM	3	1	18	33	11	0	0	0	0	0	0	0	0	0	66	21-30	51	
08:00 AM	1	2	21	44	7	1	0	0	0	0	0	0	0	0	76	21-30	65	
09:00 AM	3	7	19	20	6	0	0	0	0	0	0	0	0	0	55	21-30	39	
10:00 AM	6	2	21	15	6	0	0	0	0	0	0	0	0	0	50	21-30	36	
11:00 AM	2	2	25	42	6	1	0	0	0	0	0	0	0	0	78	21-30	67	
12:00 PM	2	5	32	26	7	0	0	0	0	0	0	0	0	0	72	21-30	58	
01:00 PM	1	6	32	26	3	1	0	0	0	0	0	0	0	0	69	21-30	58	
02:00 PM	1	6	21	57	18	1	0	0	0	0	0	0	0	0	104	21-30	78	
03:00 PM	6	1	46	68	17	2	0	1	0	0	0	0	0	0	141	21-30	114	
04:00 PM	3	1	25	66	20	1	0	0	0	0	0	0	0	0	116	21-30	91	
05:00 PM	6	5	26	54	20	1	0	0	0	0	0	0	0	0	112	21-30	80	
06:00 PM	3	2	15	49	12	1	0	0	0	0	0	0	0	0	82	21-30	64	
07:00 PM	2	2	27	27	2	1	0	0	0	0	0	0	0	0	61	21-30	54	
08:00 PM	3	1	11	21	7	0	0	0	0	0	0	0	0	0	43	21-30	32	
09:00 PM	0	1	8	12	3	1	0	0	0	0	0	0	0	0	25	21-30	20	
10:00 PM	0	1	2	8	2	0	0	0	0	0	0	0	0	0	13	25-34	10	
11:00 PM	1	0	0	8	1	0	0	0	0	0	0	0	0	0	10	26-35	9	
Day Total	45	47	359	598	157	11	0	1	0	0	0	0	0	0	1218	21-30	957	
Percent	3.7%	3.9%	29.5%	49.1%	12.9%	0.9%	0%	0.1%	0%	0%	0%	0%	0%	0%				
AM Peak Volume	10:00 AM	9:00 AM	11:00 AM	8:00 AM	7:00 AM	8:00 AM	12:00 AM	12:00 AM	12:00 AM	12:00 AM	12:00 AM	12:00 AM	12:00 AM	12:00 AM	12:00 AM	11:00 AM		
	6	7	25	44	11	1	0	0	0	0	0	0	0	0	78			
PM Peak Volume	3:00 PM	1:00 PM	3:00 PM	3:00 PM	4:00 PM	3:00 PM	12:00 PM	3:00 PM	12:00 PM	12:00 PM	12:00 PM	12:00 PM	12:00 PM	12:00 PM	3:00 PM			
	6	6	46	68	20	2	0	1	0	0	0	0	0	0	141			
<i>Comments:</i>																		

Report generated on 9/22/2023 2:43 PM

SOURCE: Quality Counts, LLC (<http://www.qualitycounts.net>)

Type of report: Tube Count - Speed Data

LOCATION: E Illinois St btwn Main St and Washington St															QC JOB #: 16302724		
SPECIFIC LOCATION:															DIRECTION: WB		
CITY/STATE: Newberg, OR															DATE: Sep 16 2023		
Start Time	1 15	16 20	21 25	26 30	31 35	36 40	41 45	46 50	51 55	56 60	61 65	66 70	71 75	76 999	Total	Pace Speed	Number in Pace
12:00 AM	0	0	3	5	1	0	0	0	0	0	0	0	0	0	9	21-30	8
01:00 AM	0	0	0	1	2	0	0	0	0	0	0	0	0	0	3	26-35	3
02:00 AM	0	0	3	2	0	1	0	0	0	0	0	0	0	0	6	21-30	5
03:00 AM	0	1	0	0	0	0	0	0	0	0	0	0	0	0	1	11-20	1
04:00 AM	0	0	1	2	0	0	0	0	0	0	0	0	0	0	3	21-30	3
05:00 AM	0	1	2	1	0	0	0	0	0	0	0	0	0	0	4	21-30	3
06:00 AM	0	0	2	2	1	0	0	0	0	0	0	0	0	0	5	21-30	4
07:00 AM	1	0	0	10	9	0	0	0	0	0	0	0	0	0	20	26-35	19
08:00 AM	2	2	12	20	18	1	0	0	0	0	0	0	0	0	55	26-35	38
09:00 AM	0	2	18	32	11	0	0	0	0	0	0	0	0	0	63	21-30	50
10:00 AM	2	5	27	44	8	1	0	0	0	0	0	0	0	0	87	21-30	71
11:00 AM	5	2	24	37	9	1	0	0	0	0	0	0	0	0	78	21-30	61
12:00 PM	3	3	27	34	10	1	0	0	0	0	0	0	0	0	78	21-30	61
01:00 PM	6	2	22	35	11	0	0	0	0	0	0	0	0	0	76	21-30	57
02:00 PM	6	0	26	27	8	0	0	0	0	0	0	0	0	0	67	21-30	53
03:00 PM	1	2	13	40	15	2	0	0	0	0	0	0	0	0	73	26-35	55
04:00 PM	2	1	16	38	13	1	0	0	0	0	0	0	0	0	71	21-30	54
05:00 PM	6	1	21	43	18	3	0	0	0	0	0	0	0	0	92	21-30	64
06:00 PM	3	1	17	25	13	1	1	0	0	0	0	0	0	0	61	21-30	42
07:00 PM	1	1	12	23	5	1	0	0	0	0	0	0	0	0	43	21-30	35
08:00 PM	3	2	7	17	5	0	0	0	0	0	0	0	0	0	34	21-30	24
09:00 PM	0	0	8	14	1	0	0	0	0	0	0	0	0	0	23	21-30	22
10:00 PM	0	0	4	4	5	0	0	0	0	0	0	0	0	0	13	26-35	9
11:00 PM	0	0	2	8	2	0	0	0	0	0	0	0	0	0	12	25-34	10
Day Total	41	26	267	464	165	13	1	0	0	0	0	0	0	0	977	21-30	731
Percent	4.2%	2.7%	27.3%	47.5%	16.9%	1.3%	0.1%	0%	0%	0%	0%	0%	0%	0%			
AM Peak Volume	11:00 AM	10:00 AM	10:00 AM	10:00 AM	8:00 AM	2:00 AM	12:00 AM	12:00 AM	12:00 AM	12:00 AM	12:00 AM	12:00 AM	12:00 AM	12:00 AM	12:00 AM	10:00 AM	
	5	5	27	44	18	1	0	0	0	0	0	0	0	0	87		
PM Peak Volume	1:00 PM	12:00 PM	12:00 PM	5:00 PM	5:00 PM	5:00 PM	6:00 PM	12:00 PM	12:00 PM	12:00 PM	12:00 PM	12:00 PM	12:00 PM	12:00 PM	5:00 PM		
	6	3	27	43	18	3	1	0	0	0	0	0	0	0	92		
<i>Comments:</i>																	

Report generated on 9/22/2023 2:43 PM

SOURCE: Quality Counts, LLC (<http://www.qualitycounts.net>)

Type of report: Tube Count - Speed Data

LOCATION: E Illinois St btwn Main St and Washington St															QC JOB #: 16302724		
SPECIFIC LOCATION:															DIRECTION: WB		
CITY/STATE: Newberg, OR															DATE: Sep 17 2023		
Start Time	1 15	16 20	21 25	26 30	31 35	36 40	41 45	46 50	51 55	56 60	61 65	66 70	71 75	76 999	Total	Pace Speed	Number in Pace
12:00 AM	0	0	1	4	1	0	0	0	0	0	0	0	0	0	6	25-34	5
01:00 AM	0	0	1	0	1	0	0	0	0	0	0	0	0	0	2	16-25	1
02:00 AM	0	0	0	1	0	0	0	0	0	0	0	0	0	0	1	21-30	1
03:00 AM	0	0	1	3	0	0	0	0	0	0	0	0	0	0	4	21-30	4
04:00 AM	0	0	0	2	4	0	0	0	0	0	0	0	0	0	6	26-35	6
05:00 AM	0	1	1	0	0	0	0	0	0	0	0	0	0	0	2	16-25	2
06:00 AM	0	0	5	4	2	0	0	0	0	0	0	0	0	0	11	21-30	9
07:00 AM	2	1	2	9	6	1	0	0	0	0	0	0	0	0	21	26-35	15
08:00 AM	0	0	3	11	5	0	0	0	0	0	0	0	0	0	19	26-35	16
09:00 AM	2	1	16	28	9	1	0	0	0	0	0	0	0	0	57	21-30	44
10:00 AM	2	5	16	40	8	1	0	0	0	0	0	0	0	0	72	21-30	56
11:00 AM	7	1	15	40	11	2	0	0	0	0	0	0	0	0	76	21-30	55
12:00 PM	7	2	25	36	9	1	0	0	0	0	0	0	0	0	80	21-30	61
01:00 PM	11	2	25	30	11	3	0	0	0	0	0	0	0	0	82	21-30	55
02:00 PM	2	4	15	43	10	1	0	0	0	0	0	0	0	0	75	21-30	58
03:00 PM	2	2	12	30	11	0	0	0	0	0	0	0	0	0	57	21-30	42
04:00 PM	1	3	24	27	15	1	0	0	0	0	0	0	0	0	71	21-30	51
05:00 PM	3	2	21	32	9	0	0	0	0	0	0	0	0	0	67	21-30	53
06:00 PM	1	1	29	23	6	0	0	0	0	0	0	0	0	0	60	21-30	52
07:00 PM	5	2	17	35	3	0	0	0	0	0	0	0	0	0	62	21-30	52
08:00 PM	1	0	14	15	1	0	0	0	0	0	0	0	0	0	31	21-30	29
09:00 PM	1	0	7	7	1	0	0	0	0	0	0	0	0	0	16	21-30	14
10:00 PM	0	0	2	4	2	0	1	0	0	0	0	0	0	0	9	26-35	6
11:00 PM	0	1	1	1	2	0	0	0	0	0	0	0	0	0	5	26-35	3
Day Total	47	28	253	425	127	11	1	0	0	0	0	0	0	0	892	21-30	678
Percent	5.3%	3.1%	28.4%	47.6%	14.2%	1.2%	0.1%	0%	0%	0%	0%	0%	0%	0%			
AM Peak Volume	11:00 AM	10:00 AM	9:00 AM	10:00 AM	11:00 AM	11:00 AM	12:00 AM	12:00 AM	12:00 AM	12:00 AM	12:00 AM	12:00 AM	12:00 AM	12:00 AM	11:00 AM		
	7	5	16	40	11	2	0	0	0	0	0	0	0	0	76		
PM Peak Volume	1:00 PM	2:00 PM	6:00 PM	2:00 PM	4:00 PM	1:00 PM	10:00 PM	12:00 PM	12:00 PM	12:00 PM	12:00 PM	12:00 PM	12:00 PM	12:00 PM	1:00 PM		
	11	4	29	43	15	3	1	0	0	0	0	0	0	0	82		
<i>Comments:</i>																	

Report generated on 9/22/2023 2:43 PM

SOURCE: Quality Counts, LLC (<http://www.qualitycounts.net>)

Type of report: Tube Count - Speed Data

LOCATION: E Illinois St btwn Main St and Washington St															QC JOB #: 16302724		
SPECIFIC LOCATION:															DIRECTION: WB		
CITY/STATE: Newberg, OR															DATE: Sep 18 2023		
Start Time	1 15	16 20	21 25	26 30	31 35	36 40	41 45	46 50	51 55	56 60	61 65	66 70	71 75	76 999	Total	Pace Speed	Number in Pace
12:00 AM	0	0	0	3	0	0	0	0	0	0	0	0	0	0	3	21-30	3
01:00 AM	0	0	0	1	1	0	0	0	0	0	0	0	0	0	2	26-35	2
02:00 AM	0	0	1	0	0	0	0	0	0	0	0	0	0	0	1	16-25	1
03:00 AM	0	0	1	0	0	0	0	0	0	0	0	0	0	0	1	16-25	1
04:00 AM	0	0	1	2	2	0	0	0	0	0	0	0	0	0	5	26-35	4
05:00 AM	0	0	4	5	5	0	0	0	0	0	0	0	0	0	14	26-35	10
06:00 AM	0	0	9	22	5	0	0	0	0	0	0	0	0	0	36	21-30	31
07:00 AM	2	2	12	34	7	0	0	0	0	0	0	0	0	0	57	21-30	46
08:00 AM	5	3	24	21	5	0	0	0	0	0	0	0	0	0	58	21-30	45
09:00 AM	1	10	18	24	6	0	0	0	0	0	0	0	0	0	59	21-30	42
10:00 AM	5	3	11	26	5	0	0	0	0	0	0	0	0	0	50	21-30	37
11:00 AM	6	4	25	29	9	0	0	0	0	0	0	0	0	0	73	21-30	54
12:00 PM	4	5	26	31	6	0	0	0	0	0	0	0	0	0	72	21-30	57
01:00 PM	8	3	19	42	6	0	0	0	0	0	0	0	0	0	78	21-30	61
02:00 PM	3	1	25	35	12	0	0	0	0	0	0	0	0	0	76	21-30	60
03:00 PM	4	3	36	66	21	2	0	0	0	0	0	0	0	0	132	21-30	102
04:00 PM	7	6	41	54	15	0	0	0	0	0	0	0	0	0	123	21-30	95
05:00 PM	1	4	35	55	19	0	0	0	0	0	0	0	0	0	114	21-30	90
06:00 PM	0	3	9	35	18	1	0	0	0	0	0	0	0	0	66	26-35	53
07:00 PM	2	3	18	34	9	2	0	0	0	0	0	0	0	0	68	21-30	52
08:00 PM	1	1	9	23	6	0	0	0	0	0	0	0	0	0	40	21-30	32
09:00 PM	0	1	12	12	7	0	0	0	0	0	0	0	0	0	32	21-30	24
10:00 PM	1	0	2	4	1	0	0	0	0	0	0	0	0	0	8	21-30	6
11:00 PM	0	0	1	2	0	0	0	0	0	0	0	0	0	0	3	21-30	3
Day Total	50	52	339	560	165	5	0	0	0	0	0	0	0	0	1171	21-30	899
Percent	4.3%	4.4%	28.9%	47.8%	14.1%	0.4%	0%	0%	0%	0%	0%	0%	0%	0%			
AM Peak Volume	11:00 AM	9:00 AM	11:00 AM	7:00 AM	11:00 AM	12:00 AM	12:00 AM	12:00 AM	12:00 AM	12:00 AM	12:00 AM	12:00 AM	12:00 AM	12:00 AM	11:00 AM		
	6	10	25	34	9	0	0	0	0	0	0	0	0	0	73		
PM Peak Volume	1:00 PM	4:00 PM	4:00 PM	3:00 PM	3:00 PM	3:00 PM	12:00 PM	12:00 PM	12:00 PM	12:00 PM	12:00 PM	12:00 PM	12:00 PM	12:00 PM	3:00 PM		
	8	6	41	66	21	2	0	0	0	0	0	0	0	0	132		

Report generated on 9/22/2023 2:43 PM

SOURCE: Quality Counts, LLC (<http://www.qualitycounts.net>)

LOCATION: E Illinois St btwn Main St and Washington St														QC JOB #: 16302724			
SPECIFIC LOCATION:														DIRECTION: WB			
CITY/STATE: Newberg, OR														DATE: Sep 12 2023 - Sep 18 2023			
Speed Range	1 15	16 20	21 25	26 30	31 35	36 40	41 45	46 50	51 55	56 60	61 65	66 70	71 75	76 999	Total	Pace Speed	Number in Pace
Grand Total	313	281	2252	3912	1129	84	3	1	0	0	0	0	0	0	7975	21-30	6164
Percent	3.9%	3.5%	28.2%	49.1%	14.2%	1.1%	0%	0%	0%	0%	0%	0%	0%	0%			
Cumulative Percent	3.9%	7.4%	35.7%	84.7%	98.9%	99.9%	100%	100%	100%	100%	100%	100%	100%	100%			
ADT 1139															85th Percentile: 30 MPH Mean Speed(Average): 26 MPH Median: 26 MPH Mode: 28 MPH		
<i>Comments:</i>																	

Report generated on 9/22/2023 2:43 PM

SOURCE: Quality Counts, LLC (<http://www.qualitycounts.net>)

TRUE DATA TO IMPROVE MOBILITY

Type of report: Tube Count - Speed Data

LOCATION: HWY 240 btwn Illinois St and North St															QC JOB #: 16302725		
SPECIFIC LOCATION:															DIRECTION: NB		
CITY/STATE: Newberg, OR															DATE: Sep 12 2023		
Start Time	1 15	16 20	21 25	26 30	31 35	36 40	41 45	46 50	51 55	56 60	61 65	66 70	71 75	76 999	Total	Pace Speed	Number in Pace
12:00 AM	0	0	4	5	0	0	0	0	0	0	0	0	0	0	9	21-30	9
01:00 AM	0	1	3	6	1	0	0	0	0	0	0	0	0	0	11	21-30	9
02:00 AM	0	1	6	8	1	0	0	0	0	0	0	0	0	0	16	21-30	14
03:00 AM	0	0	4	7	0	2	0	0	0	0	0	0	0	0	13	21-30	11
04:00 AM	0	0	17	24	9	0	0	0	0	0	0	0	0	0	50	21-30	41
05:00 AM	5	2	41	70	12	0	0	0	0	0	0	0	0	0	130	21-30	111
06:00 AM	18	13	91	131	18	1	0	0	0	0	0	0	0	0	272	21-30	222
07:00 AM	27	20	151	111	7	0	0	0	0	0	0	0	0	0	316	21-30	262
08:00 AM	44	6	129	103	3	0	0	0	0	0	0	0	0	0	285	21-30	232
09:00 AM	33	3	103	170	13	0	0	0	0	0	0	0	0	0	322	21-30	273
10:00 AM	23	7	102	111	10	0	0	0	0	0	0	0	0	0	253	21-30	213
11:00 AM	31	10	121	116	11	2	0	0	0	0	0	0	0	0	291	21-30	237
12:00 PM	35	8	150	124	11	1	0	0	0	0	0	0	0	0	329	21-30	274
01:00 PM	32	15	133	144	14	0	0	0	0	0	0	0	0	0	338	21-30	277
02:00 PM	42	7	158	152	17	0	0	0	0	0	0	0	0	0	376	21-30	310
03:00 PM	62	13	216	153	3	0	0	0	0	0	0	0	0	0	447	21-30	369
04:00 PM	71	11	243	209	6	0	0	0	0	0	0	0	0	0	540	21-30	452
05:00 PM	63	20	250	229	9	1	0	0	0	0	0	0	0	0	572	21-30	479
06:00 PM	32	8	178	171	8	0	0	0	0	0	0	0	0	0	397	21-30	349
07:00 PM	9	10	151	123	6	0	0	0	0	0	0	0	0	0	299	21-30	274
08:00 PM	14	3	72	106	10	0	0	0	0	0	0	0	0	0	205	21-30	178
09:00 PM	4	7	57	58	14	0	0	0	0	0	0	0	0	0	140	21-30	115
10:00 PM	2	4	19	47	7	1	0	0	0	0	0	0	0	0	80	21-30	66
11:00 PM	0	0	9	9	1	0	0	0	0	0	0	0	0	0	19	21-30	18
Day Total	547	169	2408	2387	191	8	0	0	0	0	0	0	0	0	5710	21-30	4795
Percent	9.6%	3%	42.2%	41.8%	3.3%	0.1%	0%	0%	0%	0%	0%	0%	0%	0%			
AM Peak Volume	8:00 AM	7:00 AM	7:00 AM	9:00 AM	6:00 AM	3:00 AM	12:00 AM	12:00 AM	12:00 AM	12:00 AM	12:00 AM	12:00 AM	12:00 AM	12:00 AM	9:00 AM		
	44	20	151	170	18	2	0	0	0	0	0	0	0	0	322		
PM Peak Volume	4:00 PM	5:00 PM	5:00 PM	5:00 PM	2:00 PM	12:00 PM	12:00 PM	12:00 PM	12:00 PM	12:00 PM	12:00 PM	12:00 PM	12:00 PM	12:00 PM	5:00 PM		
	71	20	250	229	17	1	0	0	0	0	0	0	0	0	572		
<i>Comments:</i>																	

Report generated on 9/22/2023 2:43 PM

SOURCE: Quality Counts, LLC (<http://www.qualitycounts.net>)

Type of report: Tube Count - Speed Data

LOCATION: HWY 240 btwn Illinois St and North St															QC JOB #: 16302725		
SPECIFIC LOCATION:															DIRECTION: NB		
CITY/STATE: Newberg, OR															DATE: Sep 13 2023		
Start Time	1 15	16 20	21 25	26 30	31 35	36 40	41 45	46 50	51 55	56 60	61 65	66 70	71 75	76 999	Total	Pace Speed	Number in Pace
12:00 AM	0	0	7	7	2	0	0	0	0	0	0	0	0	0	16	21-30	14
01:00 AM	0	2	1	7	1	0	0	0	0	0	0	0	0	0	11	25-34	8
02:00 AM	0	0	9	11	3	0	0	0	0	0	0	0	0	0	23	21-30	20
03:00 AM	0	0	4	8	2	0	0	0	0	0	0	0	0	0	14	21-30	12
04:00 AM	3	0	16	27	6	0	0	0	0	0	0	0	0	0	52	21-30	43
05:00 AM	3	2	39	70	17	2	0	0	0	0	0	0	0	0	133	21-30	109
06:00 AM	29	8	87	126	24	0	0	0	0	0	0	0	0	0	274	21-30	213
07:00 AM	35	9	124	110	5	0	0	0	0	0	0	0	0	0	283	21-30	234
08:00 AM	28	17	182	96	4	0	0	0	0	0	0	0	0	0	327	21-30	278
09:00 AM	26	14	154	129	12	0	0	0	0	0	0	0	0	0	335	21-30	283
10:00 AM	33	9	122	109	1	1	0	0	0	0	0	0	0	0	275	21-30	231
11:00 AM	42	15	111	114	10	0	0	1	0	0	0	0	0	0	293	21-30	225
12:00 PM	28	9	131	158	21	1	0	0	0	0	0	0	0	0	348	21-30	289
01:00 PM	36	14	129	148	20	1	0	0	0	0	0	0	0	0	348	21-30	277
02:00 PM	39	15	159	172	13	0	0	0	0	0	0	0	0	0	398	21-30	331
03:00 PM	70	15	218	228	5	0	0	0	0	0	0	0	0	0	536	21-30	446
04:00 PM	75	13	199	253	12	0	0	0	0	0	0	0	0	0	552	21-30	452
05:00 PM	71	10	217	312	5	1	0	0	0	0	0	0	0	0	616	21-30	529
06:00 PM	41	10	208	175	11	1	0	0	0	0	0	0	0	0	446	21-30	383
07:00 PM	16	2	163	105	2	0	0	0	0	0	0	0	0	0	288	21-30	268
08:00 PM	5	6	103	109	7	0	0	0	0	0	0	0	0	0	230	21-30	212
09:00 PM	4	1	57	65	8	0	0	0	0	0	0	0	0	0	135	21-30	122
10:00 PM	0	0	19	38	5	0	0	0	0	0	0	0	0	0	62	21-30	57
11:00 PM	0	0	8	21	4	0	0	0	0	0	0	0	0	0	33	21-30	29
Day Total	584	171	2467	2598	200	7	0	1	0	0	0	0	0	0	6028	21-30	5065
Percent	9.7%	2.8%	40.9%	43.1%	3.3%	0.1%	0%	0%	0%	0%	0%	0%	0%	0%			
AM Peak Volume	11:00 AM	8:00 AM	8:00 AM	9:00 AM	6:00 AM	5:00 AM	12:00 AM	11:00 AM	12:00 AM	12:00 AM	12:00 AM	12:00 AM	12:00 AM	12:00 AM	9:00 AM		
	42	17	182	129	24	2	0	1	0	0	0	0	0	0	335		
PM Peak Volume	4:00 PM	2:00 PM	3:00 PM	5:00 PM	12:00 PM	12:00 PM	12:00 PM	12:00 PM	12:00 PM	12:00 PM	12:00 PM	12:00 PM	12:00 PM	12:00 PM	5:00 PM		
	75	15	218	312	21	1	0	0	0	0	0	0	0	0	616		
<i>Comments:</i>																	

Report generated on 9/22/2023 2:43 PM

SOURCE: Quality Counts, LLC (<http://www.qualitycounts.net>)

Type of report: Tube Count - Speed Data

LOCATION: HWY 240 btwn Illinois St and North St															QC JOB #: 16302725		
SPECIFIC LOCATION:															DIRECTION: NB		
CITY/STATE: Newberg, OR															DATE: Sep 14 2023		
Start Time	1 15	16 20	21 25	26 30	31 35	36 40	41 45	46 50	51 55	56 60	61 65	66 70	71 75	76 999	Total	Pace Speed	Number in Pace
12:00 AM	0	1	6	4	1	1	0	0	0	0	0	0	0	0	13	21-30	10
01:00 AM	1	0	5	3	0	0	0	0	0	0	0	0	0	0	9	21-30	8
02:00 AM	0	0	4	5	3	0	0	0	0	0	0	0	0	0	12	21-30	9
03:00 AM	0	0	6	8	2	0	0	0	0	0	0	0	0	0	16	21-30	14
04:00 AM	1	0	17	29	7	1	0	0	0	0	0	0	0	0	55	21-30	46
05:00 AM	5	1	33	92	24	3	0	0	0	0	0	0	0	0	158	21-30	125
06:00 AM	30	7	71	149	10	2	0	0	0	0	0	0	0	0	269	21-30	220
07:00 AM	34	6	134	139	10	1	0	0	0	0	0	0	0	0	324	21-30	273
08:00 AM	36	9	133	130	11	0	0	0	0	0	0	0	0	0	319	21-30	263
09:00 AM	33	7	121	115	8	0	0	0	0	0	0	0	0	0	284	21-30	236
10:00 AM	30	7	81	136	13	0	0	0	0	0	0	0	0	0	267	21-30	217
11:00 AM	35	7	119	166	19	0	0	0	0	0	0	0	0	0	346	21-30	285
12:00 PM	49	3	137	182	18	1	0	0	0	0	0	0	0	0	390	21-30	319
01:00 PM	59	16	171	132	11	0	0	0	0	0	0	0	0	0	389	21-30	303
02:00 PM	47	16	142	190	17	1	0	0	0	0	0	0	0	0	413	21-30	332
03:00 PM	57	18	210	191	9	0	0	0	0	0	0	0	0	0	485	21-30	401
04:00 PM	70	20	219	245	13	0	0	0	0	0	0	0	0	0	567	21-30	464
05:00 PM	66	24	254	265	6	0	0	0	0	0	0	0	0	0	615	21-30	519
06:00 PM	40	6	168	169	17	0	0	0	0	0	0	0	0	0	400	21-30	337
07:00 PM	20	10	118	143	12	0	0	0	0	0	0	0	0	0	303	21-30	261
08:00 PM	7	3	105	117	7	0	0	0	0	0	0	0	0	0	239	21-30	222
09:00 PM	0	2	62	69	12	0	0	0	0	0	0	0	0	0	145	21-30	131
10:00 PM	1	2	24	38	15	0	0	0	0	0	0	0	0	0	80	21-30	62
11:00 PM	0	3	19	21	3	0	0	0	0	0	0	0	0	0	46	21-30	40
Day Total	621	168	2359	2738	248	10	0	0	0	0	0	0	0	0	6144	21-30	5097
Percent	10.1%	2.7%	38.4%	44.6%	4%	0.2%	0%	0%	0%	0%	0%	0%	0%	0%			
AM Peak Volume	8:00 AM	8:00 AM	7:00 AM	11:00 AM	5:00 AM	5:00 AM	12:00 AM	12:00 AM	12:00 AM	12:00 AM	12:00 AM	12:00 AM	12:00 AM	12:00 AM	12:00 AM	11:00 AM	
	36	9	134	166	24	3	0	0	0	0	0	0	0	0	0	346	
PM Peak Volume	4:00 PM	5:00 PM	5:00 PM	5:00 PM	12:00 PM	12:00 PM	12:00 PM	12:00 PM	12:00 PM	12:00 PM	12:00 PM	12:00 PM	12:00 PM	12:00 PM	5:00 PM		
	70	24	254	265	18	1	0	0	0	0	0	0	0	0	615		
<i>Comments:</i>																	

Report generated on 9/22/2023 2:43 PM

SOURCE: Quality Counts, LLC (<http://www.qualitycounts.net>)

Type of report: Tube Count - Speed Data

LOCATION: HWY 240 btwn Illinois St and North St															QC JOB #: 16302725		
SPECIFIC LOCATION:															DIRECTION: NB		
CITY/STATE: Newberg, OR															DATE: Sep 15 2023		
Start Time	1 15	16 20	21 25	26 30	31 35	36 40	41 45	46 50	51 55	56 60	61 65	66 70	71 75	76 999	Total	Pace Speed	Number in Pace
12:00 AM	1	0	8	12	1	0	0	0	0	0	0	0	0	0	22	21-30	20
01:00 AM	0	0	6	8	2	0	1	0	0	0	0	0	0	0	17	21-30	14
02:00 AM	0	1	7	5	0	0	0	0	0	0	0	0	0	0	13	21-30	12
03:00 AM	1	0	3	13	2	0	0	0	0	0	0	0	0	0	19	21-30	16
04:00 AM	1	0	8	14	3	0	0	0	0	0	0	0	0	0	26	21-30	22
05:00 AM	8	0	35	57	20	1	0	0	0	0	0	0	0	0	121	21-30	92
06:00 AM	20	8	77	132	28	2	0	0	0	0	0	0	0	0	267	21-30	209
07:00 AM	35	14	99	113	13	2	0	0	0	0	0	0	0	0	276	21-30	212
08:00 AM	22	24	173	106	6	1	0	0	0	0	0	0	0	0	332	21-30	279
09:00 AM	25	21	157	106	4	0	0	0	0	0	0	0	0	0	313	21-30	263
10:00 AM	27	20	165	96	4	0	0	0	0	0	0	0	0	0	312	21-30	261
11:00 AM	36	10	137	163	4	0	0	0	0	0	0	0	0	0	350	21-30	300
12:00 PM	55	15	171	137	7	0	0	0	0	0	0	0	0	0	385	21-30	308
01:00 PM	58	9	158	163	12	0	0	0	0	0	0	0	0	0	400	21-30	321
02:00 PM	67	16	189	176	21	0	0	0	0	0	0	0	0	0	469	21-30	365
03:00 PM	79	8	207	260	12	0	0	0	0	0	0	0	0	0	566	21-30	467
04:00 PM	75	3	237	279	14	1	0	0	0	0	0	0	0	0	609	21-30	516
05:00 PM	79	7	243	289	7	0	0	0	0	0	0	0	0	0	625	21-30	532
06:00 PM	43	18	178	201	10	0	0	0	0	0	0	0	0	0	450	21-30	379
07:00 PM	26	12	149	136	10	0	0	0	0	0	0	0	0	0	333	21-30	285
08:00 PM	10	6	92	123	8	0	0	0	0	0	0	0	0	0	239	21-30	215
09:00 PM	3	2	65	78	13	0	0	0	0	0	0	0	0	0	161	21-30	143
10:00 PM	6	0	41	49	7	0	0	0	0	0	0	0	0	0	103	21-30	90
11:00 PM	1	0	30	43	7	0	0	0	0	0	0	0	0	0	81	21-30	73
Day Total	678	194	2635	2759	215	7	1	0	0	0	0	0	0	0	6489	21-30	5394
Percent	10.4%	3%	40.6%	42.5%	3.3%	0.1%	0%	0%	0%	0%	0%	0%	0%	0%			
AM Peak Volume	11:00 AM	8:00 AM	8:00 AM	11:00 AM	6:00 AM	6:00 AM	1:00 AM	12:00 AM	12:00 AM	12:00 AM	12:00 AM	12:00 AM	12:00 AM	12:00 AM	12:00 AM	11:00 AM	
	36	24	173	163	28	2	1	0	0	0	0	0	0	0	0	350	
PM Peak Volume	3:00 PM	6:00 PM	5:00 PM	5:00 PM	2:00 PM	4:00 PM	12:00 PM	12:00 PM	12:00 PM	12:00 PM	12:00 PM	12:00 PM	12:00 PM	12:00 PM	12:00 PM	5:00 PM	
	79	18	243	289	21	1	0	0	0	0	0	0	0	0	0	625	
<i>Comments:</i>																	

Report generated on 9/22/2023 2:43 PM

SOURCE: Quality Counts, LLC (<http://www.qualitycounts.net>)

Type of report: Tube Count - Speed Data

LOCATION: HWY 240 btwn Illinois St and North St															QC JOB #: 16302725		
SPECIFIC LOCATION:															DIRECTION: NB		
CITY/STATE: Newberg, OR															DATE: Sep 16 2023		
Start Time	1 15	16 20	21 25	26 30	31 35	36 40	41 45	46 50	51 55	56 60	61 65	66 70	71 75	76 999	Total	Pace Speed	Number in Pace
12:00 AM	0	0	15	17	0	0	0	0	0	0	0	0	0	0	32	21-30	32
01:00 AM	0	0	9	13	2	1	1	0	0	0	0	0	0	0	26	21-30	22
02:00 AM	0	2	6	8	2	0	1	0	0	0	0	0	0	0	19	21-30	14
03:00 AM	1	0	6	11	3	0	0	0	0	0	0	0	0	0	21	21-30	17
04:00 AM	0	0	2	10	2	0	0	0	0	0	0	0	0	0	14	24-33	12
05:00 AM	3	0	43	50	12	1	0	0	0	0	0	0	0	0	109	21-30	93
06:00 AM	6	9	56	93	23	3	0	0	0	0	0	0	0	0	190	21-30	149
07:00 AM	12	2	62	85	5	1	0	0	0	0	0	0	0	0	167	21-30	147
08:00 AM	20	4	132	146	10	0	0	0	0	0	0	0	0	0	312	21-30	278
09:00 AM	26	10	157	149	5	0	0	0	0	0	0	0	0	0	347	21-30	306
10:00 AM	43	7	156	157	14	1	0	0	0	0	0	0	0	0	378	21-30	313
11:00 AM	61	5	151	160	17	0	0	0	0	0	0	0	0	0	394	21-30	311
12:00 PM	54	8	142	210	14	0	0	0	0	0	0	0	0	0	428	21-30	352
01:00 PM	47	7	171	196	20	1	0	0	0	0	0	0	0	0	442	21-30	367
02:00 PM	49	12	185	217	17	0	0	0	0	0	0	0	0	0	480	21-30	402
03:00 PM	53	12	157	207	15	0	0	0	0	0	0	0	0	0	444	21-30	364
04:00 PM	49	5	141	199	14	0	0	0	0	0	0	0	0	0	408	21-30	340
05:00 PM	59	6	122	201	33	0	0	0	0	0	0	0	0	0	421	21-30	323
06:00 PM	28	3	146	166	10	1	0	0	0	0	0	0	0	0	354	21-30	312
07:00 PM	19	6	105	154	9	0	0	0	0	0	0	0	0	0	293	21-30	259
08:00 PM	12	2	89	124	8	0	0	0	0	0	0	0	0	0	235	21-30	213
09:00 PM	12	2	68	92	10	0	0	0	0	0	0	0	0	0	184	21-30	160
10:00 PM	3	0	47	70	12	1	1	0	0	0	0	0	0	0	134	21-30	117
11:00 PM	1	2	31	56	4	0	0	0	0	0	0	0	0	0	94	21-30	87
Day Total	558	104	2199	2791	261	10	3	0	0	0	0	0	0	0	5926	21-30	4990
Percent	9.4%	1.8%	37.1%	47.1%	4.4%	0.2%	0.1%	0%	0%	0%	0%	0%	0%	0%			
AM Peak Volume	11:00 AM	9:00 AM	9:00 AM	11:00 AM	6:00 AM	6:00 AM	1:00 AM	12:00 AM	12:00 AM	12:00 AM	12:00 AM	12:00 AM	12:00 AM	12:00 AM	11:00 AM		
	61	10	157	160	23	3	1	0	0	0	0	0	0	0	394		
PM Peak Volume	5:00 PM	2:00 PM	2:00 PM	2:00 PM	5:00 PM	1:00 PM	10:00 PM	12:00 PM	12:00 PM	12:00 PM	12:00 PM	12:00 PM	12:00 PM	12:00 PM	2:00 PM		
	59	12	185	217	33	1	1	0	0	0	0	0	0	0	480		

Report generated on 9/22/2023 2:43 PM

SOURCE: Quality Counts, LLC (<http://www.qualitycounts.net>)

Type of report: Tube Count - Speed Data

LOCATION: HWY 240 btwn Illinois St and North St															QC JOB #: 16302725		
SPECIFIC LOCATION:															DIRECTION: NB		
CITY/STATE: Newberg, OR															DATE: Sep 17 2023		
Start Time	1 15	16 20	21 25	26 30	31 35	36 40	41 45	46 50	51 55	56 60	61 65	66 70	71 75	76 999	Total	Pace Speed	Number in Pace
12:00 AM	1	2	16	30	4	0	0	0	0	0	0	0	0	0	53	21-30	46
01:00 AM	0	0	9	7	2	0	0	0	0	0	0	0	0	0	18	21-30	16
02:00 AM	0	0	3	12	2	1	0	0	0	0	0	0	0	0	18	21-30	15
03:00 AM	0	0	6	5	1	0	0	0	0	0	0	0	0	0	12	21-30	11
04:00 AM	0	0	6	4	0	1	0	0	0	0	0	0	0	0	11	21-30	10
05:00 AM	1	3	25	36	13	0	0	0	0	0	0	0	0	0	78	21-30	61
06:00 AM	1	0	37	77	21	5	0	0	0	0	0	0	0	0	141	21-30	114
07:00 AM	5	4	64	68	7	1	0	0	0	0	0	0	0	0	149	21-30	132
08:00 AM	6	2	70	106	10	0	0	0	0	0	0	0	0	0	194	21-30	176
09:00 AM	18	3	87	126	12	0	0	0	0	0	0	0	0	0	246	21-30	213
10:00 AM	25	7	131	124	7	0	0	0	0	0	0	0	0	0	294	21-30	255
11:00 AM	51	3	153	147	7	2	0	0	0	0	0	0	0	0	363	21-30	300
12:00 PM	49	16	195	143	11	0	0	0	0	0	0	0	0	0	414	21-30	338
01:00 PM	55	14	225	179	6	0	0	0	0	0	0	0	0	0	479	21-30	404
02:00 PM	55	7	155	170	7	0	0	0	0	0	0	0	0	0	394	21-30	325
03:00 PM	52	9	127	170	12	0	0	0	0	0	0	0	0	0	370	21-30	297
04:00 PM	45	7	169	128	10	0	0	0	0	0	0	0	0	0	359	21-30	297
05:00 PM	36	5	153	136	4	1	0	0	0	0	0	0	0	0	335	21-30	289
06:00 PM	20	2	128	130	14	0	0	0	0	0	0	0	0	0	294	21-30	258
07:00 PM	11	2	136	86	6	2	0	0	0	0	0	0	0	0	243	21-30	222
08:00 PM	6	4	75	106	8	0	0	0	0	0	0	0	0	0	199	21-30	181
09:00 PM	4	6	45	61	4	0	0	0	0	0	0	0	0	0	120	21-30	106
10:00 PM	1	1	19	24	6	0	0	0	0	0	0	0	0	0	51	21-30	43
11:00 PM	1	0	14	12	1	0	1	0	0	0	0	0	0	0	29	21-30	26
Day Total	443	97	2048	2087	175	13	1	0	0	0	0	0	0	0	4864	21-30	4135
Percent	9.1%	2%	42.1%	42.9%	3.6%	0.3%	0%	0%	0%	0%	0%	0%	0%	0%			
AM Peak Volume	11:00 AM	10:00 AM	11:00 AM	11:00 AM	6:00 AM	6:00 AM	12:00 AM	12:00 AM	12:00 AM	12:00 AM	12:00 AM	12:00 AM	12:00 AM	12:00 AM	11:00 AM		
	51	7	153	147	21	5	0	0	0	0	0	0	0	0	363		
PM Peak Volume	1:00 PM	12:00 PM	1:00 PM	1:00 PM	6:00 PM	7:00 PM	11:00 PM	12:00 PM	12:00 PM	12:00 PM	12:00 PM	12:00 PM	12:00 PM	12:00 PM	1:00 PM		
	55	16	225	179	14	2	1	0	0	0	0	0	0	0	479		
<i>Comments:</i>																	

Report generated on 9/22/2023 2:43 PM

SOURCE: Quality Counts, LLC (<http://www.qualitycounts.net>)

Type of report: Tube Count - Speed Data

LOCATION: HWY 240 btwn Illinois St and North St															QC JOB #: 16302725		
SPECIFIC LOCATION:															DIRECTION: NB		
CITY/STATE: Newberg, OR															DATE: Sep 18 2023		
Start Time	1 15	16 20	21 25	26 30	31 35	36 40	41 45	46 50	51 55	56 60	61 65	66 70	71 75	76 999	Total	Pace Speed	Number in Pace
12:00 AM	0	0	10	3	3	0	0	0	0	0	0	0	0	0	16	21-30	13
01:00 AM	0	3	7	7	1	0	0	0	0	0	0	0	0	0	18	21-30	14
02:00 AM	0	0	5	4	3	0	0	0	0	0	0	0	0	0	12	21-30	9
03:00 AM	0	1	9	9	7	1	0	0	0	0	0	0	0	0	27	21-30	18
04:00 AM	2	0	16	26	2	0	0	0	0	0	0	0	0	0	46	21-30	42
05:00 AM	8	2	45	82	17	0	0	0	0	0	0	0	0	0	154	21-30	127
06:00 AM	22	3	106	140	26	2	0	0	0	0	0	0	0	0	299	21-30	246
07:00 AM	41	9	150	114	1	1	0	0	0	0	0	0	0	0	316	21-30	264
08:00 AM	31	11	152	109	6	0	0	0	0	0	0	0	0	0	309	21-30	261
09:00 AM	29	21	136	81	4	0	0	0	0	0	0	0	0	0	271	21-30	217
10:00 AM	27	16	138	86	7	0	0	0	0	0	0	0	0	0	274	21-30	224
11:00 AM	38	13	158	73	6	0	0	0	0	0	0	0	0	0	288	21-30	231
12:00 PM	45	14	146	114	5	0	0	0	0	0	0	0	0	0	324	21-30	260
01:00 PM	39	8	164	112	6	0	0	1	0	0	0	0	0	0	330	21-30	276
02:00 PM	33	10	170	167	9	0	0	0	0	0	0	0	0	0	389	21-30	337
03:00 PM	69	3	178	227	11	0	0	0	0	0	0	0	0	0	488	21-30	405
04:00 PM	75	8	219	276	10	1	0	0	0	0	0	0	0	0	589	21-30	495
05:00 PM	52	6	206	300	15	0	0	0	0	0	0	0	0	0	579	21-30	506
06:00 PM	30	7	176	160	9	0	0	0	0	0	0	0	0	0	382	21-30	336
07:00 PM	17	5	104	99	9	0	0	0	0	0	0	0	0	0	234	21-30	203
08:00 PM	8	4	97	91	7	0	0	0	0	0	0	0	0	0	207	21-30	188
09:00 PM	0	5	50	52	6	0	0	0	0	0	0	0	0	0	113	21-30	102
10:00 PM	0	1	28	36	3	1	0	0	0	0	0	0	0	0	69	21-30	64
11:00 PM	0	0	9	16	1	1	0	0	0	0	0	0	0	0	27	21-30	25
Day Total	566	150	2479	2384	174	7	0	1	0	0	0	0	0	0	5761	21-30	4863
Percent	9.8%	2.6%	43%	41.4%	3%	0.1%	0%	0%	0%	0%	0%	0%	0%	0%			
AM Peak Volume	7:00 AM	9:00 AM	11:00 AM	6:00 AM	6:00 AM	6:00 AM	12:00 AM	12:00 AM	12:00 AM	12:00 AM	12:00 AM	12:00 AM	12:00 AM	12:00 AM	7:00 AM		
	41	21	158	140	26	2	0	0	0	0	0	0	0	0	316		
PM Peak Volume	4:00 PM	12:00 PM	4:00 PM	5:00 PM	5:00 PM	4:00 PM	12:00 PM	1:00 PM	12:00 PM	12:00 PM	12:00 PM	12:00 PM	12:00 PM	12:00 PM	4:00 PM		
	75	14	219	300	15	1	0	1	0	0	0	0	0	0	589		

Report generated on 9/22/2023 2:43 PM

SOURCE: Quality Counts, LLC (<http://www.qualitycounts.net>)

LOCATION: HWY 240 btwn Illinois St and North St														QC JOB #: 16302725			
SPECIFIC LOCATION:														DIRECTION: NB			
CITY/STATE: Newberg, OR														DATE: Sep 12 2023 - Sep 18 2023			
Speed Range	1 15	16 20	21 25	26 30	31 35	36 40	41 45	46 50	51 55	56 60	61 65	66 70	71 75	76 999	Total	Pace Speed	Number in Pace
Grand Total	3997	1053	16595	17744	1464	62	5	2	0	0	0	0	0	0	40922	21-30	34339
Percent	9.8%	2.6%	40.6%	43.4%	3.6%	0.2%	0%	0%	0%	0%	0%	0%	0%	0%			
Cumulative Percent	9.8%	12.3%	52.9%	96.3%	99.8%	100%	100%	100%	100%	100%	100%	100%	100%	100%			
ADT 5846															85th Percentile: 28 MPH Mean Speed(Average): 24 MPH Median: 24 MPH Mode: 28 MPH		
<i>Comments:</i>																	

Report generated on 9/22/2023 2:43 PM

SOURCE: Quality Counts, LLC (<http://www.qualitycounts.net>)

TRUE DATA TO IMPROVE MOBILITY

Type of report: Tube Count - Speed Data

LOCATION: HWY 240 btwn Illinois St and North St															QC JOB #: 16302725		
SPECIFIC LOCATION:															DIRECTION: SB		
CITY/STATE: Newberg, OR															DATE: Sep 12 2023		
Start Time	1 15	16 20	21 25	26 30	31 35	36 40	41 45	46 50	51 55	56 60	61 65	66 70	71 75	76 999	Total	Pace Speed	Number in Pace
12:00 AM	0	0	1	4	3	0	0	0	0	0	0	0	0	0	8	26-35	7
01:00 AM	0	1	1	4	1	1	1	0	0	0	0	0	0	0	9	25-34	5
02:00 AM	0	0	2	2	1	0	0	0	0	0	0	0	0	0	5	21-30	4
03:00 AM	1	0	3	13	5	1	0	0	0	0	0	0	0	0	23	26-35	18
04:00 AM	0	0	5	39	20	7	0	0	0	0	0	0	0	0	71	26-35	59
05:00 AM	3	0	19	95	51	11	0	0	0	0	0	0	0	0	179	26-35	146
06:00 AM	27	6	65	191	61	6	1	0	0	0	0	0	0	0	357	21-30	256
07:00 AM	42	4	112	216	45	5	0	0	0	0	0	0	0	0	424	21-30	328
08:00 AM	39	1	64	215	67	5	0	1	0	0	0	0	0	0	392	26-35	282
09:00 AM	31	1	45	181	105	6	1	0	0	0	0	0	0	0	370	26-35	286
10:00 AM	28	5	83	160	60	9	0	0	0	0	0	0	0	1	346	21-30	243
11:00 AM	27	3	88	174	48	4	2	0	0	0	0	0	0	0	346	21-30	262
12:00 PM	39	3	63	158	32	1	0	0	0	0	0	0	0	0	296	21-30	221
01:00 PM	34	1	51	151	62	8	0	0	0	0	0	0	0	0	307	26-35	213
02:00 PM	46	6	69	163	64	9	0	1	0	0	0	0	0	0	358	21-30	232
03:00 PM	71	7	96	177	52	5	1	0	0	0	0	0	0	0	409	21-30	273
04:00 PM	81	18	77	146	47	6	2	0	0	0	0	0	0	0	377	21-30	223
05:00 PM	83	3	70	168	45	5	0	0	0	0	0	0	0	0	374	21-30	238
06:00 PM	42	4	66	152	52	5	0	0	0	0	0	0	0	0	321	21-30	218
07:00 PM	29	8	57	92	24	2	0	0	0	0	0	0	0	0	212	21-30	149
08:00 PM	18	2	34	83	19	3	1	0	0	0	0	0	0	0	160	21-30	117
09:00 PM	6	0	12	42	16	6	0	0	0	0	0	0	0	0	82	26-35	58
10:00 PM	1	0	4	13	13	1	0	0	0	0	0	0	0	0	32	26-35	26
11:00 PM	0	0	1	6	3	1	0	0	0	0	0	0	0	0	11	26-35	9
Day Total	648	73	1088	2645	896	107	9	2	0	0	0	0	0	1	5469	21-30	3733
Percent	11.8%	1.3%	19.9%	48.4%	16.4%	2%	0.2%	0%	0%	0%	0%	0%	0%	0%			
AM Peak Volume	7:00 AM	6:00 AM	7:00 AM	7:00 AM	9:00 AM	5:00 AM	11:00 AM	8:00 AM	12:00 AM	12:00 AM	12:00 AM	12:00 AM	12:00 AM	12:00 AM	10:00 AM	7:00 AM	
	42	6	112	216	105	11	2	1	0	0	0	0	0	1	424		
PM Peak Volume	5:00 PM	4:00 PM	3:00 PM	3:00 PM	2:00 PM	2:00 PM	4:00 PM	2:00 PM	12:00 PM	12:00 PM	12:00 PM	12:00 PM	12:00 PM	12:00 PM	3:00 PM		
	83	18	96	177	64	9	2	1	0	0	0	0	0	0	409		
<i>Comments:</i>																	

Report generated on 9/22/2023 2:43 PM

SOURCE: Quality Counts, LLC (<http://www.qualitycounts.net>)

Type of report: Tube Count - Speed Data

LOCATION: HWY 240 btwn Illinois St and North St															QC JOB #: 16302725		
SPECIFIC LOCATION:															DIRECTION: SB		
CITY/STATE: Newberg, OR															DATE: Sep 13 2023		
Start Time	1 15	16 20	21 25	26 30	31 35	36 40	41 45	46 50	51 55	56 60	61 65	66 70	71 75	76 999	Total	Pace Speed	Number in Pace
12:00 AM	0	0	3	5	3	0	0	0	0	0	0	0	0	0	11	21-30	8
01:00 AM	0	0	1	4	1	0	0	0	1	0	0	0	0	0	7	25-34	5
02:00 AM	0	0	2	5	3	1	0	0	0	0	0	0	0	0	11	26-35	8
03:00 AM	0	0	1	14	4	3	0	0	0	0	0	0	0	0	22	26-35	18
04:00 AM	4	0	4	38	24	3	0	0	0	0	0	0	0	0	73	26-35	62
05:00 AM	10	1	25	95	41	4	2	0	0	0	0	0	0	0	178	26-35	136
06:00 AM	28	1	55	209	54	2	0	0	0	0	0	0	0	0	349	21-30	264
07:00 AM	28	10	137	206	52	2	0	0	0	0	0	0	0	0	435	21-30	343
08:00 AM	50	14	114	196	52	6	0	0	0	0	0	0	0	0	432	21-30	310
09:00 AM	27	4	68	178	58	6	0	0	0	0	0	0	0	0	341	21-30	246
10:00 AM	34	10	117	154	36	5	0	0	0	0	0	0	0	0	356	21-30	271
11:00 AM	41	6	83	182	54	7	0	0	0	0	0	0	0	0	373	21-30	265
12:00 PM	33	4	56	157	60	3	1	0	0	0	0	0	0	0	314	26-35	217
01:00 PM	34	11	64	163	55	9	0	0	0	0	0	0	0	0	336	21-30	227
02:00 PM	52	3	70	174	68	7	0	0	1	0	0	0	0	0	375	21-30	244
03:00 PM	77	26	87	226	72	9	0	2	0	0	0	0	0	0	499	21-30	313
04:00 PM	76	4	66	146	80	7	0	1	0	0	0	0	0	0	380	26-35	226
05:00 PM	75	2	57	186	74	12	1	0	0	0	0	0	0	0	407	26-35	260
06:00 PM	53	9	51	157	65	4	2	0	0	0	0	0	0	0	341	26-35	222
07:00 PM	24	4	48	73	38	4	0	0	0	0	0	0	0	0	191	21-30	121
08:00 PM	6	2	33	65	30	5	0	0	0	0	0	0	0	0	141	21-30	98
09:00 PM	4	0	15	39	16	4	0	0	0	0	0	0	0	0	78	26-35	55
10:00 PM	1	0	7	24	10	1	0	0	0	0	0	0	0	0	43	26-35	34
11:00 PM	0	0	5	7	5	1	0	0	0	0	0	0	0	0	18	21-30	12
Day Total	657	111	1169	2703	955	105	6	3	2	0	0	0	0	0	5711	21-30	3872
Percent	11.5%	1.9%	20.5%	47.3%	16.7%	1.8%	0.1%	0.1%	0%	0%	0%	0%	0%	0%			
AM Peak Volume	8:00 AM 50	8:00 AM 14	7:00 AM 137	6:00 AM 209	9:00 AM 58	11:00 AM 7	5:00 AM 2	12:00 AM 0	1:00 AM 1	12:00 AM 0	12:00 AM 0	12:00 AM 0	12:00 AM 0	12:00 AM 0	7:00 AM 435		
PM Peak Volume	3:00 PM 77	3:00 PM 26	3:00 PM 87	3:00 PM 226	4:00 PM 80	5:00 PM 12	6:00 PM 2	3:00 PM 2	2:00 PM 1	12:00 PM 0	12:00 PM 0	12:00 PM 0	12:00 PM 0	12:00 PM 0	3:00 PM 499		
<i>Comments:</i>																	

Report generated on 9/22/2023 2:43 PM

SOURCE: Quality Counts, LLC (<http://www.qualitycounts.net>)

Type of report: Tube Count - Speed Data

LOCATION: HWY 240 btwn Illinois St and North St															QC JOB #: 16302725		
SPECIFIC LOCATION:															DIRECTION: SB		
CITY/STATE: Newberg, OR															DATE: Sep 14 2023		
Start Time	1 15	16 20	21 25	26 30	31 35	36 40	41 45	46 50	51 55	56 60	61 65	66 70	71 75	76 999	Total	Pace Speed	Number in Pace
12:00 AM	1	0	0	6	2	0	0	0	0	0	0	0	0	0	9	26-35	8
01:00 AM	0	0	3	4	1	0	0	0	0	0	0	0	0	0	8	21-30	7
02:00 AM	0	0	2	9	3	0	0	0	0	0	0	0	0	0	14	26-35	12
03:00 AM	2	0	2	15	6	0	0	0	0	0	0	0	0	0	25	26-35	21
04:00 AM	0	0	6	33	22	4	0	0	0	0	0	0	0	0	65	26-35	55
05:00 AM	6	1	27	107	40	2	0	0	0	0	0	0	0	0	183	26-35	147
06:00 AM	44	6	41	153	78	8	0	0	0	0	0	0	0	0	330	26-35	231
07:00 AM	50	6	72	257	62	5	2	0	0	0	0	0	0	0	454	21-30	329
08:00 AM	54	7	54	204	73	8	2	0	0	0	0	0	0	0	402	26-35	277
09:00 AM	27	1	38	179	72	6	0	0	0	0	0	0	0	0	323	26-35	251
10:00 AM	40	10	84	189	68	5	0	0	0	0	0	0	0	0	396	21-30	273
11:00 AM	31	5	92	177	62	6	0	0	0	0	0	0	0	0	373	21-30	269
12:00 PM	54	5	88	171	51	11	0	0	0	0	0	0	0	0	380	21-30	259
01:00 PM	56	24	89	152	37	2	1	0	0	0	1	0	0	0	362	21-30	241
02:00 PM	44	9	89	162	58	6	2	0	0	0	0	0	0	0	370	21-30	251
03:00 PM	65	5	99	199	74	7	1	0	0	0	0	0	0	0	450	21-30	298
04:00 PM	77	12	49	148	72	11	1	0	0	0	0	0	0	0	370	26-35	220
05:00 PM	76	6	60	154	74	8	1	0	0	0	0	0	0	0	379	26-35	228
06:00 PM	49	6	59	150	39	8	1	0	0	0	0	0	0	0	312	21-30	209
07:00 PM	23	3	83	112	18	1	0	0	0	0	0	0	0	1	241	21-30	195
08:00 PM	11	0	30	85	26	1	0	0	0	0	0	0	0	0	153	21-30	115
09:00 PM	1	2	10	42	13	5	1	0	0	0	0	0	0	0	74	26-35	55
10:00 PM	3	0	8	31	12	2	1	0	0	0	0	0	0	0	57	26-35	43
11:00 PM	0	1	0	6	8	2	0	0	0	0	0	0	0	0	17	26-35	14
Day Total	714	109	1085	2745	971	108	13	0	0	0	1	0	0	1	5747	21-30	3830
Percent	12.4%	1.9%	18.9%	47.8%	16.9%	1.9%	0.2%	0%	0%	0%	0%	0%	0%	0%			
AM Peak Volume	8:00 AM	10:00 AM	11:00 AM	7:00 AM	6:00 AM	6:00 AM	7:00 AM	12:00 AM	12:00 AM	12:00 AM	12:00 AM	12:00 AM	12:00 AM	12:00 AM	7:00 AM		
	54	10	92	257	78	8	2	0	0	0	0	0	0	0	454		
PM Peak Volume	4:00 PM	1:00 PM	3:00 PM	3:00 PM	3:00 PM	12:00 PM	2:00 PM	12:00 PM	12:00 PM	12:00 PM	1:00 PM	12:00 PM	12:00 PM	7:00 PM	3:00 PM		
	77	24	99	199	74	11	2	0	0	0	1	0	0	1	450		
<i>Comments:</i>																	

Report generated on 9/22/2023 2:43 PM

SOURCE: Quality Counts, LLC (<http://www.qualitycounts.net>)

Type of report: Tube Count - Speed Data

LOCATION: HWY 240 btwn Illinois St and North St														QC JOB #: 16302725			
SPECIFIC LOCATION:														DIRECTION: SB			
CITY/STATE: Newberg, OR														DATE: Sep 15 2023			
Start Time	1 15	16 20	21 25	26 30	31 35	36 40	41 45	46 50	51 55	56 60	61 65	66 70	71 75	76 999	Total	Pace Speed	Number in Pace
12:00 AM	0	0	0	4	2	0	0	1	0	0	0	0	0	0	7	26-35	6
01:00 AM	0	0	2	3	3	1	0	0	0	0	0	0	0	0	9	26-35	6
02:00 AM	0	0	1	3	4	0	0	0	0	0	0	0	0	0	8	26-35	7
03:00 AM	1	0	0	9	5	1	0	0	0	0	0	0	0	0	16	26-35	14
04:00 AM	0	0	3	29	18	2	1	0	0	0	0	0	0	0	53	26-35	47
05:00 AM	8	0	21	78	36	2	0	0	0	0	0	0	0	0	145	26-35	114
06:00 AM	25	4	45	155	65	4	0	0	0	0	0	0	0	0	298	26-35	220
07:00 AM	39	6	95	222	55	6	0	0	0	0	0	0	0	1	424	21-30	317
08:00 AM	56	5	96	192	54	9	0	0	0	0	0	0	0	0	412	21-30	288
09:00 AM	39	8	87	174	51	5	2	0	0	0	0	0	0	1	367	21-30	261
10:00 AM	45	8	110	163	38	0	0	0	0	0	0	0	0	0	364	21-30	273
11:00 AM	48	12	86	182	54	3	0	0	0	0	0	0	0	0	385	21-30	268
12:00 PM	46	5	104	165	46	4	0	0	0	0	0	0	0	0	370	21-30	269
01:00 PM	54	14	66	150	46	7	1	0	0	0	0	0	0	0	338	21-30	216
02:00 PM	54	8	66	173	71	7	1	0	0	0	0	0	0	0	380	26-35	244
03:00 PM	66	3	65	176	71	7	1	0	0	0	0	0	0	0	389	26-35	247
04:00 PM	74	3	49	159	79	12	1	0	0	0	0	0	0	0	377	26-35	238
05:00 PM	68	1	38	168	77	11	2	0	0	0	0	0	0	0	365	26-35	245
06:00 PM	33	3	68	156	48	7	1	0	0	0	0	0	0	0	316	21-30	224
07:00 PM	20	2	71	123	31	1	0	0	0	0	0	0	0	0	248	21-30	194
08:00 PM	6	1	35	88	36	6	0	1	0	0	0	0	0	0	173	26-35	124
09:00 PM	9	1	22	68	23	4	0	0	0	0	0	0	0	0	127	26-35	91
10:00 PM	3	2	12	47	23	7	0	0	0	0	0	0	0	0	94	26-35	70
11:00 PM	0	0	3	18	11	1	1	0	0	0	0	0	0	0	34	26-35	29
Day Total	694	86	1145	2705	947	107	11	2	0	0	0	0	0	2	5699	21-30	3850
Percent	12.2%	1.5%	20.1%	47.5%	16.6%	1.9%	0.2%	0%	0%	0%	0%	0%	0%	0%			
AM Peak Volume	8:00 AM	11:00 AM	10:00 AM	7:00 AM	6:00 AM	8:00 AM	9:00 AM	12:00 AM	12:00 AM	12:00 AM	12:00 AM	12:00 AM	12:00 AM	7:00 AM	7:00 AM		
	56	12	110	222	65	9	2	1	0	0	0	0	0	1	424		
PM Peak Volume	4:00 PM	1:00 PM	12:00 PM	3:00 PM	4:00 PM	4:00 PM	5:00 PM	8:00 PM	12:00 PM	12:00 PM	12:00 PM	12:00 PM	12:00 PM	12:00 PM	3:00 PM		
	74	14	104	176	79	12	2	1	0	0	0	0	0	0	389		
<i>Comments:</i>																	

Report generated on 9/22/2023 2:43 PM

SOURCE: Quality Counts, LLC (<http://www.qualitycounts.net>)

Type of report: Tube Count - Speed Data

LOCATION: HWY 240 btwn Illinois St and North St															QC JOB #: 16302725		
SPECIFIC LOCATION:															DIRECTION: SB		
CITY/STATE: Newberg, OR															DATE: Sep 16 2023		
Start Time	1 15	16 20	21 25	26 30	31 35	36 40	41 45	46 50	51 55	56 60	61 65	66 70	71 75	76 999	Total	Pace Speed	Number in Pace
12:00 AM	0	1	2	9	8	2	0	0	0	0	0	0	0	0	22	26-35	17
01:00 AM	0	0	4	9	3	1	0	0	0	0	0	0	0	0	17	21-30	13
02:00 AM	0	0	1	1	6	1	0	0	0	0	0	0	0	0	9	26-35	7
03:00 AM	0	1	3	11	1	0	0	0	0	0	0	0	0	0	16	21-30	14
04:00 AM	1	0	3	13	4	1	0	0	0	0	0	0	0	0	22	26-35	17
05:00 AM	2	0	11	24	8	2	0	0	0	0	0	0	0	0	47	21-30	35
06:00 AM	8	2	17	54	15	2	0	0	0	0	0	0	0	0	98	21-30	71
07:00 AM	11	1	41	105	39	2	0	0	0	0	0	0	0	0	199	21-30	146
08:00 AM	14	0	38	125	65	6	1	0	0	0	0	0	0	0	249	26-35	190
09:00 AM	32	4	74	191	59	11	0	0	0	0	0	0	0	0	371	21-30	265
10:00 AM	53	2	66	220	76	4	0	0	0	0	0	0	0	0	421	26-35	296
11:00 AM	70	13	110	243	67	5	0	0	0	0	0	0	0	0	508	21-30	353
12:00 PM	57	2	106	236	65	9	0	0	0	0	0	0	0	0	475	21-30	342
01:00 PM	58	2	66	209	67	8	1	0	0	0	0	0	0	0	411	26-35	276
02:00 PM	58	6	74	173	72	3	1	0	0	0	0	0	0	0	387	21-30	247
03:00 PM	45	1	50	194	87	11	1	0	0	0	0	0	0	0	389	26-35	281
04:00 PM	40	8	51	180	85	10	1	0	0	0	0	0	0	0	375	26-35	265
05:00 PM	54	5	70	199	87	15	3	0	0	0	0	0	0	0	433	26-35	286
06:00 PM	43	0	64	136	44	3	1	0	0	0	0	0	0	0	291	21-30	200
07:00 PM	19	9	51	113	45	4	0	0	0	0	0	0	0	0	241	21-30	164
08:00 PM	22	2	52	112	46	6	0	0	0	0	0	0	0	0	240	21-30	164
09:00 PM	9	1	46	96	40	5	0	0	0	0	0	0	0	0	197	21-30	142
10:00 PM	4	0	12	49	22	2	1	0	0	0	0	0	0	0	90	26-35	71
11:00 PM	1	2	7	31	11	6	0	1	0	0	0	0	0	0	59	26-35	42
Day Total	601	62	1019	2733	1022	119	10	1	0	0	0	0	0	0	5567	26-35	3755
Percent	10.8%	1.1%	18.3%	49.1%	18.4%	2.1%	0.2%	0%	0%	0%	0%	0%	0%	0%			
AM Peak Volume	11:00 AM	11:00 AM	11:00 AM	11:00 AM	10:00 AM	9:00 AM	8:00 AM	12:00 AM	12:00 AM	12:00 AM	12:00 AM	12:00 AM	12:00 AM	12:00 AM	11:00 AM		
	70	13	110	243	76	11	1	0	0	0	0	0	0	0	508		
PM Peak Volume	1:00 PM	7:00 PM	12:00 PM	12:00 PM	3:00 PM	5:00 PM	5:00 PM	11:00 PM	12:00 PM	12:00 PM	12:00 PM	12:00 PM	12:00 PM	12:00 PM	12:00 PM		
	58	9	106	236	87	15	3	1	0	0	0	0	0	0	475		
<i>Comments:</i>																	

Report generated on 9/22/2023 2:43 PM

SOURCE: Quality Counts, LLC (<http://www.qualitycounts.net>)

Type of report: Tube Count - Speed Data

LOCATION: HWY 240 btwn Illinois St and North St															QC JOB #: 16302725		
SPECIFIC LOCATION:															DIRECTION: SB		
CITY/STATE: Newberg, OR															DATE: Sep 17 2023		
Start Time	1 15	16 20	21 25	26 30	31 35	36 40	41 45	46 50	51 55	56 60	61 65	66 70	71 75	76 999	Total	Pace Speed	Number in Pace
12:00 AM	1	1	3	14	11	1	0	0	0	0	0	0	0	0	31	26-35	25
01:00 AM	0	0	2	9	1	1	0	0	0	0	0	0	0	0	13	21-30	11
02:00 AM	0	0	0	3	4	1	0	0	0	0	0	0	0	0	8	26-35	7
03:00 AM	0	0	2	6	2	3	0	0	0	0	0	0	0	0	13	23-32	8
04:00 AM	0	0	1	9	7	2	0	0	0	0	0	0	0	0	19	26-35	16
05:00 AM	1	0	11	14	9	2	0	0	0	0	0	0	0	0	37	21-30	25
06:00 AM	2	0	13	28	16	4	0	0	0	0	0	0	0	0	63	26-35	44
07:00 AM	7	6	30	74	28	7	0	0	0	0	0	0	0	0	152	21-30	104
08:00 AM	6	1	34	99	41	6	0	0	0	0	0	0	0	0	187	26-35	140
09:00 AM	35	15	52	183	55	9	1	0	0	0	0	0	0	0	350	26-35	238
10:00 AM	46	15	75	157	49	6	1	0	0	0	0	0	0	0	349	21-30	232
11:00 AM	44	10	99	210	74	8	0	0	0	0	0	0	0	0	445	21-30	309
12:00 PM	65	12	88	148	62	5	1	0	0	0	0	0	0	0	381	21-30	236
01:00 PM	61	2	101	187	49	5	1	0	0	0	0	0	0	0	406	21-30	288
02:00 PM	51	6	72	184	60	9	0	0	0	0	0	0	0	0	382	21-30	256
03:00 PM	42	2	73	179	61	4	0	0	1	0	0	0	0	0	362	21-30	252
04:00 PM	42	10	91	160	51	8	0	0	0	0	0	0	0	0	362	21-30	251
05:00 PM	47	4	83	193	56	6	0	0	0	0	0	0	0	0	389	21-30	276
06:00 PM	27	1	41	143	35	7	1	1	0	0	0	0	0	0	256	21-30	184
07:00 PM	23	3	58	97	37	6	0	0	0	0	0	0	0	1	225	21-30	155
08:00 PM	9	0	34	82	35	1	0	0	0	0	0	0	0	0	161	26-35	117
09:00 PM	4	0	20	34	18	5	2	1	1	0	0	0	0	0	85	21-30	54
10:00 PM	0	3	10	19	8	2	0	0	0	0	0	0	0	0	42	21-30	29
11:00 PM	0	1	6	13	3	2	0	0	0	0	0	0	0	0	25	21-30	19
Day Total	513	92	999	2245	772	110	7	2	2	0	0	0	0	1	4743	21-30	3244
Percent	10.8%	1.9%	21.1%	47.3%	16.3%	2.3%	0.1%	0%	0%	0%	0%	0%	0%	0%			
AM Peak Volume	10:00 AM	9:00 AM	11:00 AM	11:00 AM	11:00 AM	9:00 AM	9:00 AM	12:00 AM	12:00 AM	12:00 AM	12:00 AM	12:00 AM	12:00 AM	12:00 AM	11:00 AM		
	46	15	99	210	74	9	1	0	0	0	0	0	0	0	445		
PM Peak Volume	12:00 PM	12:00 PM	1:00 PM	5:00 PM	12:00 PM	2:00 PM	9:00 PM	6:00 PM	3:00 PM	12:00 PM	12:00 PM	12:00 PM	12:00 PM	7:00 PM	1:00 PM		
	65	12	101	193	62	9	2	1	1	0	0	0	0	1	406		
<i>Comments:</i>																	

Report generated on 9/22/2023 2:43 PM

SOURCE: Quality Counts, LLC (<http://www.qualitycounts.net>)

Type of report: Tube Count - Speed Data

LOCATION: HWY 240 btwn Illinois St and North St															QC JOB #: 16302725		
SPECIFIC LOCATION:															DIRECTION: SB		
CITY/STATE: Newberg, OR															DATE: Sep 18 2023		
Start Time	1 15	16 20	21 25	26 30	31 35	36 40	41 45	46 50	51 55	56 60	61 65	66 70	71 75	76 999	Total	Pace Speed	Number in Pace
12:00 AM	0	0	3	7	2	1	0	0	0	0	0	0	0	0	13	21-30	10
01:00 AM	1	0	3	2	2	1	0	0	0	0	0	0	0	0	9	21-30	5
02:00 AM	0	0	2	2	1	0	0	0	0	0	0	0	0	0	5	21-30	4
03:00 AM	0	0	3	13	3	0	0	0	0	0	0	0	0	0	19	21-30	16
04:00 AM	3	0	18	43	18	3	0	0	0	0	0	0	0	0	85	21-30	61
05:00 AM	6	1	32	86	41	1	0	0	0	0	0	0	0	0	167	26-35	127
06:00 AM	23	0	86	188	42	5	0	0	0	0	0	0	0	0	344	21-30	274
07:00 AM	34	10	127	189	47	2	0	0	0	0	0	0	0	0	409	21-30	316
08:00 AM	39	15	115	181	27	3	0	0	0	0	0	0	0	1	381	21-30	296
09:00 AM	34	11	152	158	27	1	0	0	0	0	0	0	0	0	383	21-30	310
10:00 AM	35	12	120	151	14	4	1	0	0	0	0	0	0	0	337	21-30	271
11:00 AM	37	15	148	156	38	3	0	0	0	0	0	0	0	0	397	21-30	304
12:00 PM	44	9	108	152	25	3	0	0	0	0	0	0	0	0	341	21-30	260
01:00 PM	44	8	93	140	32	1	0	0	0	0	0	0	0	0	318	21-30	233
02:00 PM	46	9	62	153	62	8	0	0	0	0	0	0	0	0	340	26-35	215
03:00 PM	69	21	68	206	84	14	0	1	0	0	0	0	0	0	463	26-35	290
04:00 PM	91	4	47	143	76	11	1	1	0	0	0	0	0	0	374	26-35	219
05:00 PM	63	6	53	142	78	9	0	0	0	0	0	0	0	0	351	26-35	220
06:00 PM	27	3	64	136	54	8	1	0	0	0	0	0	0	0	293	21-30	200
07:00 PM	17	0	50	85	35	5	1	1	0	0	0	0	0	0	194	21-30	135
08:00 PM	10	2	25	67	42	1	0	0	0	0	0	0	0	0	147	26-35	109
09:00 PM	2	0	14	42	37	4	0	0	0	0	0	0	0	0	99	26-35	79
10:00 PM	0	2	5	29	10	4	0	0	0	0	0	0	0	0	50	26-35	39
11:00 PM	0	1	5	8	4	1	0	0	0	0	0	0	0	0	19	21-30	13
Day Total	625	129	1403	2479	801	93	4	3	0	0	0	0	0	1	5538	21-30	3882
Percent	11.3%	2.3%	25.3%	44.8%	14.5%	1.7%	0.1%	0.1%	0%	0%	0%	0%	0%	0%			
AM Peak Volume	8:00 AM 39	8:00 AM 15	9:00 AM 152	7:00 AM 189	7:00 AM 47	6:00 AM 5	10:00 AM 1	12:00 AM 0	12:00 AM 0	12:00 AM 0	12:00 AM 0	12:00 AM 0	12:00 AM 0	8:00 AM 1	7:00 AM 409		
PM Peak Volume	4:00 PM 91	3:00 PM 21	12:00 PM 108	3:00 PM 206	3:00 PM 84	3:00 PM 14	4:00 PM 1	3:00 PM 1	12:00 PM 0	12:00 PM 0	12:00 PM 0	12:00 PM 0	12:00 PM 0	12:00 PM 0	3:00 PM 463		
<i>Comments:</i>																	

Report generated on 9/22/2023 2:43 PM

SOURCE: Quality Counts, LLC (<http://www.qualitycounts.net>)

SUMMARY - Tube Count - Speed Data

LOCATION: HWY 240 btwn Illinois St and North St														QC JOB #: 16302725			
SPECIFIC LOCATION:														DIRECTION: SB			
CITY/STATE: Newberg, OR														DATE: Sep 12 2023 - Sep 18 2023			
Speed Range	1 15	16 20	21 25	26 30	31 35	36 40	41 45	46 50	51 55	56 60	61 65	66 70	71 75	76 999	Total	Pace Speed	Number in Pace
Grand Total	4452	662	7908	18255	6364	749	60	13	4	0	1	0	0	6	38474	21-30	26163
Percent	11.6%	1.7%	20.6%	47.4%	16.5%	1.9%	0.2%	0%	0%	0%	0%	0%	0%	0%			
Cumulative Percent	11.6%	13.3%	33.8%	81.3%	97.8%	99.8%	99.9%	100%	100%	100%	100%	100%	100%	100%			
ADT 5496															85th Percentile: 31 MPH Mean Speed(Average): 26 MPH Median: 26 MPH Mode: 28 MPH		
<i>Comments:</i>																	

Report generated on 9/22/2023 2:43 PM

SOURCE: Quality Counts, LLC (<http://www.qualitycounts.net>)

TRUE DATA TO IMPROVE MOBILITY

Type of report: Tube Count - Speed Data

LOCATION: HWY 240 btwn Grant St and Main St															QC JOB #: 16302726		
SPECIFIC LOCATION:															DIRECTION: EB		
CITY/STATE: Newberg, OR															DATE: Sep 12 2023		
Start Time	1 15	16 20	21 25	26 30	31 35	36 40	41 45	46 50	51 55	56 60	61 65	66 70	71 75	76 999	Total	Pace Speed	Number in Pace
12:00 AM	0	2	6	1	0	0	0	0	0	0	0	0	0	0	9	16-25	8
01:00 AM	0	3	1	0	0	0	0	0	0	0	0	0	0	0	4	16-25	4
02:00 AM	0	1	3	0	0	0	0	0	0	0	0	0	0	0	4	16-25	4
03:00 AM	1	2	11	5	0	0	0	0	0	0	0	0	0	0	19	21-30	16
04:00 AM	0	5	56	21	1	0	0	0	0	0	0	0	0	0	83	21-30	77
05:00 AM	6	14	113	36	2	0	0	0	0	0	0	0	0	0	171	21-30	149
06:00 AM	16	54	231	42	0	0	0	0	0	0	0	0	0	0	343	16-25	285
07:00 AM	48	62	247	43	0	0	0	0	0	0	0	0	0	0	400	16-25	309
08:00 AM	17	55	242	61	0	0	0	0	0	0	0	0	0	0	375	21-30	303
09:00 AM	17	29	197	73	3	0	0	0	0	0	0	0	0	0	319	21-30	270
10:00 AM	16	65	186	42	0	0	0	0	0	0	0	0	0	0	309	16-25	251
11:00 AM	11	37	230	40	1	0	0	0	0	0	0	0	0	0	319	21-30	270
12:00 PM	21	44	166	37	0	0	0	0	0	0	0	0	0	0	268	16-25	210
01:00 PM	14	34	201	57	0	0	0	0	0	0	0	0	0	0	306	21-30	258
02:00 PM	24	34	187	42	1	0	0	0	0	0	0	0	0	0	288	21-30	229
03:00 PM	31	55	201	53	1	0	0	0	0	0	0	0	0	0	341	16-25	256
04:00 PM	34	55	205	56	1	0	0	0	0	0	0	0	0	0	351	21-30	261
05:00 PM	35	28	220	56	1	0	0	0	0	0	0	0	0	0	340	21-30	276
06:00 PM	15	31	160	43	0	0	0	0	0	1	0	0	0	0	250	21-30	203
07:00 PM	6	24	87	29	1	0	0	0	0	0	0	0	0	0	147	21-30	116
08:00 PM	7	26	88	15	2	0	0	0	0	0	0	0	0	0	138	16-25	114
09:00 PM	2	11	38	12	0	0	0	0	0	0	0	0	0	0	63	21-30	50
10:00 PM	0	6	16	6	0	0	0	0	0	0	0	0	0	0	28	16-25	22
11:00 PM	0	0	9	4	0	0	0	0	0	0	0	0	0	0	13	21-30	13
Day Total	321	677	3101	774	14	0	0	0	0	1	0	0	0	0	4888	21-30	3875
Percent	6.6%	13.9%	63.4%	15.8%	0.3%	0%	0%	0%	0%	0%	0%	0%	0%	0%			
AM Peak Volume	7:00 AM 48	10:00 AM 65	7:00 AM 247	9:00 AM 73	9:00 AM 3	12:00 AM 0	12:00 AM 0	12:00 AM 0	12:00 AM 0	12:00 AM 0	12:00 AM 0	12:00 AM 0	12:00 AM 0	12:00 AM 0	7:00 AM 400		
PM Peak Volume	5:00 PM 35	3:00 PM 55	5:00 PM 220	1:00 PM 57	8:00 PM 2	12:00 PM 0	12:00 PM 0	12:00 PM 0	12:00 PM 0	6:00 PM 1	12:00 PM 0	12:00 PM 0	12:00 PM 0	12:00 PM 0	4:00 PM 351		
<i>Comments:</i>																	

Report generated on 9/22/2023 2:43 PM

SOURCE: Quality Counts, LLC (<http://www.qualitycounts.net>)

Type of report: Tube Count - Speed Data

LOCATION: HWY 240 btwn Grant St and Main St															QC JOB #: 16302726		
SPECIFIC LOCATION:															DIRECTION: EB		
CITY/STATE: Newberg, OR															DATE: Sep 13 2023		
Start Time	1 15	16 20	21 25	26 30	31 35	36 40	41 45	46 50	51 55	56 60	61 65	66 70	71 75	76 999	Total	Pace Speed	Number in Pace
12:00 AM	0	3	6	2	0	0	0	0	0	0	0	0	0	0	11	16-25	9
01:00 AM	0	1	5	0	0	0	0	0	0	0	0	0	0	0	6	16-25	6
02:00 AM	0	0	6	2	0	0	0	0	0	0	0	0	0	0	8	21-30	8
03:00 AM	0	1	11	8	0	0	0	0	0	0	0	0	0	0	20	21-30	19
04:00 AM	0	3	52	19	1	0	0	0	0	0	0	0	0	0	75	21-30	71
05:00 AM	3	23	122	26	3	0	0	0	0	0	0	0	0	0	177	21-30	148
06:00 AM	19	39	224	51	1	0	0	0	0	0	0	0	0	0	334	21-30	275
07:00 AM	22	28	280	58	0	0	0	0	0	0	0	0	0	0	388	21-30	338
08:00 AM	30	89	240	50	0	0	0	0	0	0	0	0	0	0	409	16-25	329
09:00 AM	21	64	218	47	0	0	0	0	0	0	0	0	0	0	350	16-25	282
10:00 AM	26	49	192	43	0	0	0	0	0	0	0	0	0	0	310	16-25	241
11:00 AM	21	59	207	49	0	0	0	0	0	0	0	0	0	0	336	16-25	266
12:00 PM	21	22	160	43	2	0	0	0	0	0	0	0	0	0	248	21-30	203
01:00 PM	27	28	179	46	0	0	0	0	0	0	0	0	0	0	280	21-30	225
02:00 PM	20	50	212	52	2	0	0	0	0	0	0	0	0	0	336	21-30	264
03:00 PM	39	54	251	62	1	0	0	0	0	0	0	0	0	0	407	21-30	313
04:00 PM	42	52	216	57	1	0	0	0	0	0	0	0	0	0	368	21-30	273
05:00 PM	20	43	232	61	1	0	0	0	0	0	0	0	0	0	357	21-30	293
06:00 PM	18	20	143	58	3	1	0	0	0	0	0	0	0	0	243	21-30	201
07:00 PM	5	33	91	35	1	0	0	0	0	0	0	0	0	0	165	21-30	126
08:00 PM	4	12	72	26	0	0	0	0	0	0	0	0	0	0	114	21-30	98
09:00 PM	0	15	46	12	1	0	0	0	0	0	0	0	0	0	74	16-25	61
10:00 PM	3	9	25	9	0	0	0	0	0	0	0	0	0	0	46	16-25	34
11:00 PM	0	0	10	3	0	0	0	0	0	0	0	0	0	0	13	21-30	13
Day Total	341	697	3200	819	17	1	0	0	0	0	0	0	0	0	5075	21-30	4019
Percent	6.7%	13.7%	63.1%	16.1%	0.3%	0%	0%	0%	0%	0%	0%	0%	0%	0%			
AM Peak Volume	8:00 AM 30	8:00 AM 89	7:00 AM 280	7:00 AM 58	5:00 AM 3	12:00 AM 0	12:00 AM 0	12:00 AM 0	12:00 AM 0	12:00 AM 0	12:00 AM 0	12:00 AM 0	12:00 AM 0	12:00 AM 0	8:00 AM 409		
PM Peak Volume	4:00 PM 42	3:00 PM 54	3:00 PM 251	3:00 PM 62	6:00 PM 3	6:00 PM 1	12:00 PM 0	12:00 PM 0	12:00 PM 0	12:00 PM 0	12:00 PM 0	12:00 PM 0	12:00 PM 0	12:00 PM 0	3:00 PM 407		
<i>Comments:</i>																	

Report generated on 9/22/2023 2:43 PM

SOURCE: Quality Counts, LLC (<http://www.qualitycounts.net>)

Type of report: Tube Count - Speed Data

LOCATION: HWY 240 btwn Grant St and Main St															QC JOB #: 16302726		
SPECIFIC LOCATION:															DIRECTION: EB		
CITY/STATE: Newberg, OR															DATE: Sep 14 2023		
Start Time	1 15	16 20	21 25	26 30	31 35	36 40	41 45	46 50	51 55	56 60	61 65	66 70	71 75	76 999	Total	Pace Speed	Number in Pace
12:00 AM	0	0	5	4	0	0	0	0	0	0	0	0	0	0	9	21-30	9
01:00 AM	2	1	3	0	0	0	0	0	0	0	0	0	0	0	6	16-25	4
02:00 AM	1	1	6	1	0	0	0	0	0	0	0	0	0	0	9	16-25	7
03:00 AM	0	2	15	5	0	0	0	0	0	0	0	0	0	0	22	21-30	20
04:00 AM	0	7	41	27	1	0	0	0	0	0	0	0	0	0	76	21-30	68
05:00 AM	4	26	108	36	2	0	0	0	0	0	0	0	0	0	176	21-30	144
06:00 AM	16	21	196	52	7	0	0	0	0	0	0	0	0	0	292	21-30	248
07:00 AM	27	53	264	57	1	0	0	0	0	0	0	0	0	0	402	21-30	321
08:00 AM	37	52	247	54	0	0	0	0	0	0	0	0	0	0	390	21-30	301
09:00 AM	21	43	188	55	3	0	0	0	0	0	0	0	0	0	310	21-30	243
10:00 AM	21	48	216	48	1	0	0	0	0	0	0	0	0	0	334	16-25	264
11:00 AM	20	55	208	53	1	0	0	0	0	0	0	0	0	0	337	16-25	263
12:00 PM	33	56	215	45	2	0	0	0	0	0	0	0	0	0	351	16-25	271
01:00 PM	25	68	196	37	0	0	0	0	0	0	0	0	0	0	326	16-25	264
02:00 PM	44	52	193	59	0	0	0	0	0	0	0	0	0	0	348	21-30	252
03:00 PM	57	55	228	54	1	0	0	0	0	0	0	0	0	0	395	16-25	283
04:00 PM	44	33	215	67	2	0	0	0	0	0	0	0	0	0	361	21-30	282
05:00 PM	52	54	195	61	0	0	0	0	0	0	0	0	1	0	363	21-30	256
06:00 PM	23	45	167	34	1	0	0	0	0	0	0	0	0	0	270	16-25	212
07:00 PM	13	25	132	31	2	0	0	0	0	0	0	0	0	0	203	21-30	163
08:00 PM	4	26	81	21	0	0	0	0	0	0	0	0	0	0	132	16-25	107
09:00 PM	2	12	38	7	1	0	0	0	0	0	0	0	0	0	60	16-25	50
10:00 PM	3	6	37	7	1	0	0	0	0	0	0	0	0	0	54	21-30	44
11:00 PM	0	0	13	2	0	0	0	0	0	0	0	0	0	0	15	21-30	15
Day Total	449	741	3207	817	26	0	0	0	0	0	0	0	1	0	5241	21-30	4024
Percent	8.6%	14.1%	61.2%	15.6%	0.5%	0%	0%	0%	0%	0%	0%	0%	0%	0%			
AM Peak Volume	8:00 AM 37	11:00 AM 55	7:00 AM 264	7:00 AM 57	6:00 AM 7	12:00 AM 0	12:00 AM 0	12:00 AM 0	12:00 AM 0	12:00 AM 0	12:00 AM 0	12:00 AM 0	12:00 AM 0	12:00 AM 0	7:00 AM 402		
PM Peak Volume	3:00 PM 57	1:00 PM 68	3:00 PM 228	4:00 PM 67	12:00 PM 2	12:00 PM 0	12:00 PM 0	12:00 PM 0	12:00 PM 0	12:00 PM 0	12:00 PM 0	12:00 PM 0	5:00 PM 1	12:00 PM 0	3:00 PM 395		
<i>Comments:</i>																	

Report generated on 9/22/2023 2:43 PM

SOURCE: Quality Counts, LLC (<http://www.qualitycounts.net>)

Type of report: Tube Count - Speed Data

LOCATION: HWY 240 btwn Grant St and Main St															QC JOB #: 16302726		
SPECIFIC LOCATION:															DIRECTION: EB		
CITY/STATE: Newberg, OR															DATE: Sep 15 2023		
Start Time	1 15	16 20	21 25	26 30	31 35	36 40	41 45	46 50	51 55	56 60	61 65	66 70	71 75	76 999	Total	Pace Speed	Number in Pace
12:00 AM	0	0	5	1	0	0	0	0	0	0	0	0	0	0	6	21-30	6
01:00 AM	1	1	4	1	0	0	0	0	0	0	0	0	0	0	7	20-29	5
02:00 AM	0	2	2	1	0	0	0	0	0	0	0	0	0	0	5	16-25	4
03:00 AM	0	1	11	3	0	0	0	0	0	0	0	0	0	0	15	21-30	14
04:00 AM	0	3	34	17	1	0	0	0	0	0	0	0	0	0	55	21-30	51
05:00 AM	2	24	87	30	0	0	0	0	0	0	0	0	0	0	143	21-30	117
06:00 AM	17	38	167	36	0	0	0	0	0	0	0	0	0	0	258	16-25	205
07:00 AM	25	76	248	55	0	0	0	0	0	0	0	0	0	0	404	16-25	324
08:00 AM	27	66	219	62	2	0	0	0	0	0	0	0	0	0	376	16-25	285
09:00 AM	22	37	200	48	2	0	0	0	1	0	0	0	0	0	310	21-30	248
10:00 AM	15	53	223	43	1	0	0	0	0	0	0	0	0	0	335	16-25	276
11:00 AM	27	63	177	46	2	0	0	0	0	0	0	0	0	0	315	16-25	240
12:00 PM	27	44	184	54	0	0	0	0	0	0	0	0	0	0	309	21-30	238
01:00 PM	37	48	187	49	3	0	0	0	0	0	0	0	0	0	324	21-30	236
02:00 PM	46	68	192	42	2	0	0	0	0	0	0	0	0	0	350	16-25	260
03:00 PM	49	34	206	68	1	0	0	0	0	0	0	0	0	0	358	21-30	274
04:00 PM	41	23	218	59	2	0	0	1	0	0	0	0	0	2	346	21-30	277
05:00 PM	46	32	182	40	0	0	0	0	0	0	0	0	0	0	300	21-30	222
06:00 PM	23	24	194	44	1	0	0	0	0	0	0	0	0	0	286	21-30	238
07:00 PM	10	27	135	29	3	0	0	0	0	0	0	0	0	0	204	21-30	164
08:00 PM	2	19	104	23	1	0	1	0	0	0	0	0	0	0	150	21-30	127
09:00 PM	3	9	81	22	0	0	0	0	0	0	0	0	0	0	115	21-30	103
10:00 PM	2	14	61	10	2	0	0	0	0	0	0	0	0	0	89	16-25	75
11:00 PM	1	4	20	7	0	0	0	0	0	0	0	0	0	0	32	21-30	27
Day Total	423	710	3141	790	23	0	1	1	1	0	0	0	0	2	5092	21-30	3931
Percent	8.3%	13.9%	61.7%	15.5%	0.5%	0%	0%	0%	0%	0%	0%	0%	0%	0%			
AM Peak Volume	8:00 AM 27	7:00 AM 76	7:00 AM 248	8:00 AM 62	8:00 AM 2	12:00 AM 0	12:00 AM 0	12:00 AM 0	9:00 AM 1	12:00 AM 0	12:00 AM 0	12:00 AM 0	12:00 AM 0	12:00 AM 0	7:00 AM 404		
PM Peak Volume	3:00 PM 49	2:00 PM 68	4:00 PM 218	3:00 PM 68	1:00 PM 3	12:00 PM 0	8:00 PM 1	4:00 PM 1	12:00 PM 0	12:00 PM 0	12:00 PM 0	12:00 PM 0	12:00 PM 0	4:00 PM 2	3:00 PM 358		
<i>Comments:</i>																	

Report generated on 9/22/2023 2:43 PM

SOURCE: Quality Counts, LLC (<http://www.qualitycounts.net>)

Type of report: Tube Count - Speed Data

LOCATION: HWY 240 btwn Grant St and Main St															QC JOB #: 16302726			
SPECIFIC LOCATION:															DIRECTION: EB			
CITY/STATE: Newberg, OR															DATE: Sep 16 2023			
Start Time	1 15	16 20	21 25	26 30	31 35	36 40	41 45	46 50	51 55	56 60	61 65	66 70	71 75	76 999	Total	Pace Speed	Number in Pace	
12:00 AM	3	3	11	3	0	0	0	0	0	0	0	0	0	0	20	16-25	14	
01:00 AM	0	3	10	1	0	0	0	0	0	0	0	0	0	0	14	16-25	13	
02:00 AM	0	0	1	4	0	0	0	0	0	0	0	0	0	0	5	21-30	5	
03:00 AM	0	4	9	1	0	0	0	0	0	0	0	0	0	0	14	16-25	13	
04:00 AM	2	2	18	2	0	0	0	0	0	0	0	0	0	0	24	16-25	20	
05:00 AM	1	5	30	9	1	0	0	0	0	0	0	0	0	0	46	21-30	39	
06:00 AM	1	15	53	14	0	0	0	0	0	0	0	0	0	0	83	16-25	68	
07:00 AM	6	19	106	30	0	0	0	0	0	0	0	0	0	0	161	21-30	136	
08:00 AM	11	15	138	58	1	0	0	0	0	0	0	0	0	0	223	21-30	196	
09:00 AM	15	39	198	52	0	0	0	0	0	0	0	0	0	0	304	21-30	250	
10:00 AM	22	50	209	51	2	0	0	0	0	0	0	0	0	0	334	21-30	260	
11:00 AM	33	62	245	54	0	0	0	0	0	0	0	0	0	0	394	16-25	307	
12:00 PM	31	40	258	48	0	0	0	0	0	0	0	0	0	0	377	21-30	306	
01:00 PM	29	36	227	62	0	0	0	0	0	0	0	0	0	0	354	21-30	289	
02:00 PM	26	39	222	58	2	0	1	0	0	0	0	0	0	0	348	21-30	280	
03:00 PM	26	43	254	77	1	0	0	0	0	0	0	0	0	0	401	21-30	331	
04:00 PM	21	32	235	62	0	0	0	1	0	0	0	0	0	0	351	21-30	297	
05:00 PM	31	39	235	74	2	0	0	0	0	0	0	0	0	0	381	21-30	309	
06:00 PM	10	23	175	37	1	1	0	0	0	0	0	0	0	0	247	21-30	212	
07:00 PM	13	32	135	34	2	0	0	0	0	0	0	0	0	0	216	21-30	169	
08:00 PM	6	36	154	27	0	0	0	0	0	0	0	0	0	0	223	16-25	190	
09:00 PM	11	25	109	25	0	0	0	0	0	0	0	0	0	0	170	16-25	134	
10:00 PM	0	11	60	13	0	0	0	0	0	0	0	0	0	0	84	21-30	73	
11:00 PM	0	8	42	6	1	0	0	0	0	0	0	0	0	0	57	16-25	50	
Day Total	298	581	3134	802	13	1	1	1	0	0	0	0	0	0	4831	21-30	3936	
Percent	6.2%	12%	64.9%	16.6%	0.3%	0%	0%	0%	0%	0%	0%	0%	0%	0%				
AM Peak Volume	11:00 AM 33	11:00 AM 62	11:00 AM 245	8:00 AM 58	10:00 AM 2	12:00 AM 0	12:00 AM 0	12:00 AM 0	12:00 AM 0	12:00 AM 0	12:00 AM 0	12:00 AM 0	12:00 AM 0	12:00 AM 0	11:00 AM 394			
PM Peak Volume	12:00 PM 31	3:00 PM 43	12:00 PM 258	3:00 PM 77	2:00 PM 2	6:00 PM 1	2:00 PM 1	4:00 PM 1	12:00 PM 0	12:00 PM 0	12:00 PM 0	12:00 PM 0	12:00 PM 0	12:00 PM 0	3:00 PM 401			
<i>Comments:</i>																		

Report generated on 9/22/2023 2:43 PM

SOURCE: Quality Counts, LLC (<http://www.qualitycounts.net>)

Type of report: Tube Count - Speed Data

LOCATION: HWY 240 btwn Grant St and Main St															QC JOB #: 16302726		
SPECIFIC LOCATION:															DIRECTION: EB		
CITY/STATE: Newberg, OR															DATE: Sep 17 2023		
Start Time	1 15	16 20	21 25	26 30	31 35	36 40	41 45	46 50	51 55	56 60	61 65	66 70	71 75	76 999	Total	Pace Speed	Number in Pace
12:00 AM	2	4	21	4	0	0	0	0	0	0	0	0	0	0	31	21-30	25
01:00 AM	0	6	5	2	0	0	0	0	0	0	0	0	0	0	13	16-25	11
02:00 AM	0	1	6	3	0	0	0	0	0	0	0	0	0	0	10	21-30	9
03:00 AM	0	4	3	3	0	0	0	0	0	0	0	0	0	0	10	16-25	7
04:00 AM	0	2	17	3	0	0	0	0	0	0	0	0	0	0	22	21-30	20
05:00 AM	1	5	24	6	0	0	0	0	0	0	0	0	0	0	36	21-30	30
06:00 AM	0	5	32	14	0	0	0	0	0	0	0	0	0	0	51	21-30	46
07:00 AM	2	14	72	28	0	0	0	0	0	0	0	0	0	0	116	21-30	100
08:00 AM	6	24	101	44	0	0	0	0	0	0	0	0	0	0	175	21-30	145
09:00 AM	11	42	200	46	0	0	0	0	0	0	0	0	0	0	299	21-30	246
10:00 AM	12	32	220	46	1	0	0	0	0	0	0	0	0	0	311	21-30	266
11:00 AM	11	46	239	70	4	1	0	0	0	0	0	0	0	0	371	21-30	309
12:00 PM	35	60	227	67	3	0	0	0	0	0	0	0	0	0	392	21-30	294
01:00 PM	36	36	231	47	2	0	0	0	0	0	0	0	0	0	352	21-30	278
02:00 PM	27	29	199	53	2	0	0	0	0	0	0	0	0	0	310	21-30	252
03:00 PM	27	31	208	55	0	0	0	0	0	0	0	0	0	0	321	21-30	263
04:00 PM	11	28	207	42	1	0	0	0	0	0	0	0	0	0	289	21-30	249
05:00 PM	28	30	198	58	0	0	0	0	0	0	0	0	0	1	315	21-30	256
06:00 PM	8	15	132	55	2	0	0	0	0	0	0	0	0	0	212	21-30	187
07:00 PM	17	28	102	28	1	0	0	0	0	0	0	0	0	0	176	16-25	130
08:00 PM	4	13	97	31	1	0	0	0	0	0	0	0	0	0	146	21-30	128
09:00 PM	0	9	49	15	1	0	0	0	0	0	0	0	0	0	74	21-30	64
10:00 PM	1	3	23	8	0	0	0	0	0	0	0	0	0	0	35	21-30	31
11:00 PM	0	6	16	2	0	0	0	0	0	0	0	0	0	0	24	16-25	22
Day Total	239	473	2629	730	18	1	0	0	0	0	0	0	0	1	4091	21-30	3359
Percent	5.8%	11.6%	64.3%	17.8%	0.4%	0%	0%	0%	0%	0%	0%	0%	0%	0%			
AM Peak Volume	10:00 AM	11:00 AM	11:00 AM	11:00 AM	11:00 AM	11:00 AM	12:00 AM	12:00 AM	12:00 AM	12:00 AM	12:00 AM	12:00 AM	12:00 AM	12:00 AM	11:00 AM		
	12	46	239	70	4	1	0	0	0	0	0	0	0	0	371		
PM Peak Volume	1:00 PM	12:00 PM	1:00 PM	12:00 PM	12:00 PM	12:00 PM	12:00 PM	12:00 PM	12:00 PM	12:00 PM	12:00 PM	12:00 PM	12:00 PM	5:00 PM	12:00 PM		
	36	60	231	67	3	0	0	0	0	0	0	0	0	1	392		
<i>Comments:</i>																	

Report generated on 9/22/2023 2:43 PM

SOURCE: Quality Counts, LLC (<http://www.qualitycounts.net>)

Type of report: Tube Count - Speed Data

LOCATION: HWY 240 btwn Grant St and Main St															QC JOB #: 16302726		
SPECIFIC LOCATION:															DIRECTION: EB		
CITY/STATE: Newberg, OR															DATE: Sep 18 2023		
Start Time	1 15	16 20	21 25	26 30	31 35	36 40	41 45	46 50	51 55	56 60	61 65	66 70	71 75	76 999	Total	Pace Speed	Number in Pace
12:00 AM	0	3	8	2	0	0	0	0	0	0	0	0	0	0	13	16-25	11
01:00 AM	0	2	1	3	0	0	0	0	0	0	0	0	0	0	6	21-30	4
02:00 AM	0	0	6	0	0	0	0	0	0	0	0	0	0	0	6	16-25	6
03:00 AM	1	2	14	2	0	0	0	0	0	0	0	0	0	0	19	20-29	16
04:00 AM	0	8	55	30	1	0	0	0	0	0	0	0	0	0	94	21-30	85
05:00 AM	6	23	100	23	1	0	0	0	0	0	0	0	0	0	153	16-25	123
06:00 AM	16	46	212	38	1	0	0	0	0	0	0	0	0	0	313	16-25	258
07:00 AM	28	73	268	25	2	0	0	0	0	0	0	0	0	0	396	16-25	341
08:00 AM	28	64	235	34	0	0	0	0	0	0	0	0	0	0	361	16-25	299
09:00 AM	26	77	203	27	1	0	0	0	0	0	0	0	0	0	334	16-25	280
10:00 AM	28	69	174	32	1	0	0	0	0	0	0	0	0	0	304	16-25	243
11:00 AM	31	63	190	26	1	0	0	0	0	0	0	0	0	0	311	16-25	253
12:00 PM	19	58	201	37	1	0	0	0	0	0	0	0	0	0	316	16-25	259
01:00 PM	17	52	212	36	1	0	0	0	0	0	1	0	0	0	319	16-25	264
02:00 PM	27	34	182	56	3	0	0	0	0	0	0	0	0	0	302	21-30	238
03:00 PM	48	41	221	61	1	0	0	0	0	0	0	0	0	0	372	21-30	282
04:00 PM	39	38	212	59	1	0	0	0	0	0	0	0	0	0	349	21-30	271
05:00 PM	33	46	178	56	0	0	0	0	0	0	0	0	0	0	313	21-30	234
06:00 PM	18	27	160	39	0	0	0	0	0	0	0	0	0	0	244	21-30	199
07:00 PM	19	23	94	31	2	0	0	0	0	0	0	0	0	0	169	21-30	125
08:00 PM	5	17	76	20	0	0	0	0	0	0	0	0	0	0	118	21-30	96
09:00 PM	2	15	52	20	0	0	0	0	0	0	0	0	0	0	89	21-30	72
10:00 PM	0	7	27	12	0	0	0	0	0	0	0	0	0	0	46	21-30	39
11:00 PM	0	3	8	4	0	0	0	0	0	0	0	0	0	0	15	21-30	12
Day Total	391	791	3089	673	17	0	0	0	0	0	1	0	0	0	4962	16-25	3880
Percent	7.9%	15.9%	62.3%	13.6%	0.3%	0%	0%	0%	0%	0%	0%	0%	0%	0%			
AM Peak Volume	11:00 AM	9:00 AM	7:00 AM	6:00 AM	7:00 AM	12:00 AM	12:00 AM	12:00 AM	12:00 AM	12:00 AM	12:00 AM	12:00 AM	12:00 AM	12:00 AM	7:00 AM		
	31	77	268	38	2	0	0	0	0	0	0	0	0	0	396		
PM Peak Volume	3:00 PM	12:00 PM	3:00 PM	3:00 PM	2:00 PM	12:00 PM	12:00 PM	12:00 PM	12:00 PM	12:00 PM	1:00 PM	12:00 PM	12:00 PM	12:00 PM	3:00 PM		
	48	58	221	61	3	0	0	0	0	0	1	0	0	0	372		
<i>Comments:</i>																	

Report generated on 9/22/2023 2:43 PM

SOURCE: Quality Counts, LLC (<http://www.qualitycounts.net>)

LOCATION: HWY 240 btwn Grant St and Main St														QC JOB #: 16302726			
SPECIFIC LOCATION:														DIRECTION: EB			
CITY/STATE: Newberg, OR														DATE: Sep 12 2023 - Sep 18 2023			
Speed Range	1 15	16 20	21 25	26 30	31 35	36 40	41 45	46 50	51 55	56 60	61 65	66 70	71 75	76 999	Total	Pace Speed	Number in Pace
Grand Total	2462	4670	21501	5405	128	3	2	2	1	1	1	0	1	3	34180	21-30	26906
Percent	7.2%	13.7%	62.9%	15.8%	0.4%	0%	0%	0%	0%	0%	0%	0%	0%	0%			
Cumulative Percent	7.2%	20.9%	83.8%	99.6%	100%	100%	100%	100%	100%	100%	100%	100%	100%	100%			
ADT 4882															85th Percentile: 25 MPH Mean Speed(Average): 22 MPH Median: 22 MPH Mode: 23 MPH		
<i>Comments:</i>																	

Report generated on 9/22/2023 2:43 PM

SOURCE: Quality Counts, LLC (<http://www.qualitycounts.net>)

TRUE DATA TO IMPROVE MOBILITY

Type of report: Tube Count - Speed Data

LOCATION: HWY 240 btwn Grant St and Main St															QC JOB #: 16302726		
SPECIFIC LOCATION:															DIRECTION: WB		
CITY/STATE: Newberg, OR															DATE: Sep 12 2023		
Start Time	1 15	16 20	21 25	26 30	31 35	36 40	41 45	46 50	51 55	56 60	61 65	66 70	71 75	76 999	Total	Pace Speed	Number in Pace
12:00 AM	0	1	5	3	0	0	0	0	0	0	0	0	0	0	9	21-30	8
01:00 AM	0	0	5	5	0	0	0	0	0	0	0	0	0	0	10	21-30	10
02:00 AM	2	2	6	5	0	0	0	0	0	0	0	0	0	0	15	21-30	11
03:00 AM	0	1	7	4	2	0	0	0	0	0	0	0	0	0	14	21-30	11
04:00 AM	0	2	9	11	1	0	0	0	0	0	0	0	0	0	23	21-30	20
05:00 AM	1	2	49	53	5	0	0	0	0	0	0	0	0	0	110	21-30	102
06:00 AM	13	8	88	120	7	0	0	0	0	0	0	0	0	0	236	21-30	208
07:00 AM	35	9	122	76	7	0	0	0	0	0	0	0	0	0	249	21-30	198
08:00 AM	27	1	99	113	4	0	0	0	0	0	0	0	0	0	244	21-30	212
09:00 AM	16	6	122	132	4	0	0	0	0	0	0	0	0	0	280	21-30	254
10:00 AM	21	13	117	79	3	0	0	0	0	0	0	0	0	0	233	21-30	196
11:00 AM	12	8	136	91	6	0	0	0	0	0	0	0	0	0	253	21-30	227
12:00 PM	23	13	165	87	6	0	0	0	0	0	0	0	0	0	294	21-30	252
01:00 PM	20	17	161	106	5	0	0	0	0	0	0	0	0	0	309	21-30	267
02:00 PM	37	8	139	124	7	0	0	0	0	0	0	0	0	0	315	21-30	263
03:00 PM	49	33	223	126	2	0	0	0	0	0	0	0	0	0	433	21-30	349
04:00 PM	57	13	270	191	4	1	0	0	0	0	0	0	0	0	536	21-30	461
05:00 PM	39	8	261	213	4	0	0	0	0	0	0	0	0	0	525	21-30	474
06:00 PM	23	13	196	99	3	0	0	0	0	0	0	0	0	0	334	21-30	295
07:00 PM	9	13	141	67	1	0	0	0	0	0	0	0	0	0	231	21-30	208
08:00 PM	4	13	119	56	0	0	0	0	0	0	0	0	0	0	192	21-30	175
09:00 PM	1	17	70	38	3	0	0	0	0	0	0	0	0	0	129	21-30	108
10:00 PM	0	2	37	34	6	0	0	0	0	0	0	0	0	0	79	21-30	71
11:00 PM	1	1	9	9	1	0	0	0	0	0	0	0	0	0	21	21-30	18
Day Total	390	204	2556	1842	81	1	0	0	0	0	0	0	0	0	5074	21-30	4398
Percent	7.7%	4%	50.4%	36.3%	1.6%	0%	0%	0%	0%	0%	0%	0%	0%	0%			
AM Peak Volume	7:00 AM	10:00 AM	11:00 AM	9:00 AM	6:00 AM	12:00 AM	12:00 AM	12:00 AM	12:00 AM	12:00 AM	12:00 AM	12:00 AM	12:00 AM	12:00 AM	9:00 AM		
	35	13	136	132	7	0	0	0	0	0	0	0	0	0	280		
PM Peak Volume	4:00 PM	3:00 PM	4:00 PM	5:00 PM	2:00 PM	4:00 PM	12:00 PM	12:00 PM	12:00 PM	12:00 PM	12:00 PM	12:00 PM	12:00 PM	12:00 PM	4:00 PM		
	57	33	270	213	7	1	0	0	0	0	0	0	0	0	536		
<i>Comments:</i>																	

Report generated on 9/22/2023 2:43 PM

SOURCE: Quality Counts, LLC (<http://www.qualitycounts.net>)

Type of report: Tube Count - Speed Data

LOCATION: HWY 240 btwn Grant St and Main St															QC JOB #: 16302726		
SPECIFIC LOCATION:															DIRECTION: WB		
CITY/STATE: Newberg, OR															DATE: Sep 13 2023		
Start Time	1 15	16 20	21 25	26 30	31 35	36 40	41 45	46 50	51 55	56 60	61 65	66 70	71 75	76 999	Total	Pace Speed	Number in Pace
12:00 AM	0	0	8	4	1	0	0	0	0	0	0	0	0	0	13	21-30	12
01:00 AM	1	1	6	4	1	0	0	0	0	0	0	0	0	0	13	21-30	10
02:00 AM	0	0	13	7	0	0	0	0	0	0	0	0	0	0	20	21-30	20
03:00 AM	0	1	7	6	1	0	0	0	0	0	0	0	0	0	15	21-30	13
04:00 AM	1	1	11	11	1	0	0	0	0	0	0	0	0	0	25	21-30	22
05:00 AM	5	1	42	62	5	1	0	0	0	0	0	0	0	0	116	21-30	104
06:00 AM	17	12	107	106	9	0	0	0	0	0	0	0	0	0	251	21-30	213
07:00 AM	24	4	124	83	8	1	0	0	0	0	0	0	0	0	244	21-30	207
08:00 AM	24	12	137	109	5	0	0	0	0	0	0	0	0	0	287	21-30	246
09:00 AM	13	11	153	134	5	0	0	0	0	0	0	0	0	0	316	21-30	287
10:00 AM	15	19	140	70	3	0	0	0	0	0	0	0	0	0	247	21-30	210
11:00 AM	25	11	137	92	5	1	0	0	0	0	0	0	0	0	271	21-30	229
12:00 PM	15	6	147	117	3	0	0	0	0	0	0	0	0	0	288	21-30	264
01:00 PM	24	13	151	108	3	0	0	0	0	0	0	0	0	0	299	21-30	259
02:00 PM	26	19	154	143	6	0	1	0	0	0	0	0	0	0	349	21-30	297
03:00 PM	47	15	210	213	4	0	0	0	0	0	0	0	0	0	489	21-30	423
04:00 PM	56	19	231	187	7	0	0	0	0	0	0	0	0	0	500	21-30	418
05:00 PM	34	14	229	234	16	0	0	0	0	0	0	0	0	0	527	21-30	463
06:00 PM	20	7	181	162	5	0	0	0	0	0	0	0	0	0	375	21-30	343
07:00 PM	9	14	154	68	2	0	0	0	0	0	0	0	0	0	247	21-30	222
08:00 PM	14	13	96	67	4	0	0	0	0	0	0	0	0	0	194	21-30	163
09:00 PM	1	11	56	37	2	0	0	0	0	0	0	0	0	0	107	21-30	93
10:00 PM	2	7	31	18	1	0	0	0	0	0	0	0	0	0	59	21-30	49
11:00 PM	0	0	15	13	1	0	0	0	0	0	0	0	0	0	29	21-30	28
Day Total	373	211	2540	2055	98	3	1	0	0	0	0	0	0	0	5281	21-30	4595
Percent	7.1%	4%	48.1%	38.9%	1.9%	0.1%	0%	0%	0%	0%	0%	0%	0%	0%			
AM Peak Volume	11:00 AM	10:00 AM	9:00 AM	9:00 AM	6:00 AM	5:00 AM	12:00 AM	12:00 AM	12:00 AM	12:00 AM	12:00 AM	12:00 AM	12:00 AM	12:00 AM	9:00 AM		
	25	19	153	134	9	1	0	0	0	0	0	0	0	0	316		
PM Peak Volume	4:00 PM	2:00 PM	4:00 PM	5:00 PM	5:00 PM	12:00 PM	2:00 PM	12:00 PM	12:00 PM	12:00 PM	12:00 PM	12:00 PM	12:00 PM	12:00 PM	5:00 PM		
	56	19	231	234	16	0	1	0	0	0	0	0	0	0	527		
<i>Comments:</i>																	

Report generated on 9/22/2023 2:43 PM

SOURCE: Quality Counts, LLC (<http://www.qualitycounts.net>)

Type of report: Tube Count - Speed Data

LOCATION: HWY 240 btwn Grant St and Main St															QC JOB #: 16302726		
SPECIFIC LOCATION:															DIRECTION: WB		
CITY/STATE: Newberg, OR															DATE: Sep 14 2023		
Start Time	1 15	16 20	21 25	26 30	31 35	36 40	41 45	46 50	51 55	56 60	61 65	66 70	71 75	76 999	Total	Pace Speed	Number in Pace
12:00 AM	0	0	8	5	1	0	0	0	0	0	0	0	0	0	14	21-30	13
01:00 AM	1	0	5	3	0	1	0	0	0	0	0	0	0	0	10	21-30	8
02:00 AM	0	0	4	8	1	0	0	0	0	0	0	0	0	0	13	21-30	12
03:00 AM	0	1	6	9	0	0	0	0	0	0	0	0	0	0	16	21-30	15
04:00 AM	0	1	11	12	2	0	0	0	0	0	0	0	0	0	26	21-30	23
05:00 AM	5	3	42	76	11	0	0	0	0	0	0	0	0	0	137	21-30	118
06:00 AM	21	10	92	124	11	0	0	0	0	0	0	0	0	0	258	21-30	216
07:00 AM	23	9	117	108	6	0	0	0	0	0	0	0	0	0	263	21-30	225
08:00 AM	30	7	128	117	12	0	0	0	0	0	0	0	0	0	294	21-30	245
09:00 AM	16	10	132	106	5	0	0	0	0	0	0	0	0	0	269	21-30	238
10:00 AM	19	6	115	101	6	0	0	0	0	0	0	0	0	0	247	21-30	216
11:00 AM	20	8	157	90	5	0	0	0	0	0	0	0	0	0	280	21-30	247
12:00 PM	35	10	175	112	4	1	0	0	0	0	0	0	0	0	337	21-30	287
01:00 PM	33	28	142	107	2	0	0	0	0	0	0	0	0	0	312	21-30	249
02:00 PM	37	19	206	123	1	1	0	0	0	0	0	0	0	0	387	21-30	329
03:00 PM	47	25	210	174	9	0	0	0	0	0	0	0	0	0	465	21-30	384
04:00 PM	57	26	256	206	6	0	0	0	0	0	0	0	0	0	551	21-30	462
05:00 PM	53	22	264	190	10	1	0	0	0	0	0	0	0	0	540	21-30	454
06:00 PM	22	19	163	139	7	0	0	0	0	0	0	0	0	0	350	21-30	302
07:00 PM	18	7	129	93	4	0	0	0	0	0	0	0	0	0	251	21-30	222
08:00 PM	4	12	116	69	5	0	0	0	0	0	0	0	0	0	206	21-30	185
09:00 PM	1	4	65	58	5	0	0	0	0	0	0	0	0	0	133	21-30	123
10:00 PM	2	3	36	26	6	0	0	0	0	0	0	0	0	0	73	21-30	62
11:00 PM	1	4	23	16	2	0	0	0	0	0	0	0	0	0	46	21-30	39
Day Total	445	234	2602	2072	121	4	0	0	0	0	0	0	0	0	5478	21-30	4674
Percent	8.1%	4.3%	47.5%	37.8%	2.2%	0.1%	0%	0%	0%	0%	0%	0%	0%	0%			
AM Peak Volume	8:00 AM 30	6:00 AM 10	11:00 AM 157	6:00 AM 124	8:00 AM 12	1:00 AM 1	12:00 AM 0	12:00 AM 0	12:00 AM 0	12:00 AM 0	12:00 AM 0	12:00 AM 0	12:00 AM 0	12:00 AM 0	8:00 AM 294		
PM Peak Volume	4:00 PM 57	1:00 PM 28	5:00 PM 264	4:00 PM 206	5:00 PM 10	12:00 PM 1	12:00 PM 0	12:00 PM 0	12:00 PM 0	12:00 PM 0	12:00 PM 0	12:00 PM 0	12:00 PM 0	12:00 PM 0	4:00 PM 551		
<i>Comments:</i>																	

Report generated on 9/22/2023 2:43 PM

SOURCE: Quality Counts, LLC (<http://www.qualitycounts.net>)

Type of report: Tube Count - Speed Data

LOCATION: HWY 240 btwn Grant St and Main St															QC JOB #: 16302726		
SPECIFIC LOCATION:															DIRECTION: WB		
CITY/STATE: Newberg, OR															DATE: Sep 15 2023		
Start Time	1 15	16 20	21 25	26 30	31 35	36 40	41 45	46 50	51 55	56 60	61 65	66 70	71 75	76 999	Total	Pace Speed	Number in Pace
12:00 AM	0	0	11	7	0	0	0	0	0	0	0	0	0	0	18	21-30	18
01:00 AM	0	1	5	11	0	0	0	0	0	0	0	0	0	0	17	21-30	16
02:00 AM	0	2	5	5	0	0	0	0	0	0	0	0	0	0	12	21-30	10
03:00 AM	1	0	6	10	0	0	0	0	0	0	0	0	0	0	17	21-30	16
04:00 AM	0	0	11	11	0	0	0	0	0	0	0	0	0	0	22	21-30	22
05:00 AM	3	3	48	53	4	0	0	0	0	0	0	0	0	0	111	21-30	101
06:00 AM	14	8	96	106	8	0	0	0	0	0	0	0	0	0	232	21-30	202
07:00 AM	26	5	118	103	4	1	0	0	0	0	0	0	0	0	257	21-30	221
08:00 AM	32	11	136	113	7	0	0	0	0	0	0	0	0	0	299	21-30	249
09:00 AM	17	20	101	111	6	0	0	0	0	0	0	0	0	0	255	21-30	212
10:00 AM	14	23	126	102	1	0	0	0	0	0	0	0	0	0	266	21-30	228
11:00 AM	31	21	121	125	7	0	0	0	0	0	0	0	0	0	305	21-30	246
12:00 PM	29	17	154	128	5	0	0	0	0	0	0	0	0	0	333	21-30	282
01:00 PM	34	7	180	135	8	0	0	0	0	0	0	0	0	0	364	21-30	315
02:00 PM	45	18	197	139	2	0	0	0	0	0	0	0	0	0	401	21-30	336
03:00 PM	53	15	268	213	11	0	0	0	0	0	0	0	0	0	560	21-30	481
04:00 PM	50	12	217	234	13	1	0	0	0	0	0	0	0	0	527	21-30	451
05:00 PM	45	10	249	201	4	0	0	0	0	0	0	0	0	0	509	21-30	450
06:00 PM	23	9	219	145	8	0	0	0	0	0	0	0	0	0	404	21-30	364
07:00 PM	9	13	134	103	1	0	0	0	0	0	0	0	0	0	260	21-30	237
08:00 PM	10	12	106	64	2	0	0	0	0	0	0	0	0	0	194	21-30	170
09:00 PM	4	8	80	45	0	0	0	0	0	0	0	0	0	0	137	21-30	125
10:00 PM	3	6	38	38	2	0	0	0	0	0	0	0	0	0	87	21-30	76
11:00 PM	1	4	27	32	2	0	0	0	0	0	0	0	0	0	66	21-30	59
Day Total	444	225	2653	2234	95	2	0	0	0	0	0	0	0	0	5653	21-30	4887
Percent	7.9%	4%	46.9%	39.5%	1.7%	0%	0%	0%	0%	0%	0%	0%	0%	0%			
AM Peak Volume	8:00 AM 32	10:00 AM 23	8:00 AM 136	11:00 AM 125	6:00 AM 8	7:00 AM 1	12:00 AM 0	12:00 AM 0	12:00 AM 0	12:00 AM 0	12:00 AM 0	12:00 AM 0	12:00 AM 0	12:00 AM 0	11:00 AM 305		
PM Peak Volume	3:00 PM 53	2:00 PM 18	3:00 PM 268	4:00 PM 234	4:00 PM 13	4:00 PM 1	12:00 PM 0	12:00 PM 0	12:00 PM 0	12:00 PM 0	12:00 PM 0	12:00 PM 0	12:00 PM 0	12:00 PM 0	3:00 PM 560		
<i>Comments:</i>																	

Report generated on 9/22/2023 2:43 PM

SOURCE: Quality Counts, LLC (<http://www.qualitycounts.net>)

Type of report: Tube Count - Speed Data

LOCATION: HWY 240 btwn Grant St and Main St															QC JOB #: 16302726		
SPECIFIC LOCATION:															DIRECTION: WB		
CITY/STATE: Newberg, OR															DATE: Sep 16 2023		
Start Time	1 15	16 20	21 25	26 30	31 35	36 40	41 45	46 50	51 55	56 60	61 65	66 70	71 75	76 999	Total	Pace Speed	Number in Pace
12:00 AM	2	5	16	11	1	0	0	0	0	0	0	0	0	0	35	21-30	27
01:00 AM	0	0	7	17	2	0	0	0	0	0	0	0	0	0	26	21-30	24
02:00 AM	0	0	5	6	2	1	0	1	0	0	0	0	0	0	15	21-30	11
03:00 AM	0	1	7	11	1	0	0	0	0	0	0	0	0	0	20	21-30	18
04:00 AM	0	0	4	8	0	0	0	0	0	0	0	0	0	0	12	21-30	12
05:00 AM	0	0	52	45	9	0	0	0	0	0	0	0	0	0	106	21-30	97
06:00 AM	1	6	72	83	9	0	0	0	0	0	0	0	0	0	171	21-30	155
07:00 AM	4	3	67	68	3	0	0	0	0	0	0	0	0	0	145	21-30	135
08:00 AM	12	0	80	115	8	0	0	0	0	0	0	0	0	0	215	21-30	195
09:00 AM	14	2	101	109	4	0	0	0	0	0	0	0	0	0	230	21-30	210
10:00 AM	19	12	102	140	9	0	0	0	0	0	0	0	0	0	282	21-30	242
11:00 AM	35	12	130	144	4	0	0	0	0	0	0	0	0	0	325	21-30	274
12:00 PM	42	23	178	139	4	0	0	0	0	0	0	0	0	0	386	21-30	317
01:00 PM	35	11	136	172	2	0	0	0	0	0	0	0	0	0	356	21-30	308
02:00 PM	33	8	184	173	14	0	0	0	0	0	0	0	0	0	412	21-30	357
03:00 PM	25	13	178	168	11	0	0	0	0	0	0	0	0	0	395	21-30	346
04:00 PM	36	14	142	167	11	1	0	0	0	0	0	0	0	0	371	21-30	309
05:00 PM	30	12	161	156	11	0	0	0	0	0	0	0	0	0	370	21-30	317
06:00 PM	23	4	157	142	9	1	0	0	0	0	0	0	0	0	336	21-30	299
07:00 PM	7	7	117	104	5	0	0	0	0	0	0	0	0	0	240	21-30	221
08:00 PM	6	9	93	78	4	0	0	0	0	0	0	0	0	0	190	21-30	171
09:00 PM	5	5	67	62	5	0	0	0	0	0	0	0	0	0	144	21-30	129
10:00 PM	2	2	44	59	6	1	0	0	0	0	0	0	0	0	114	21-30	103
11:00 PM	0	5	27	44	1	0	0	0	0	0	0	0	0	0	77	21-30	71
Day Total	331	154	2127	2221	135	4	0	1	0	0	0	0	0	0	4973	21-30	4348
Percent	6.7%	3.1%	42.8%	44.7%	2.7%	0.1%	0%	0%	0%	0%	0%	0%	0%	0%			
AM Peak Volume	11:00 AM	10:00 AM	11:00 AM	11:00 AM	5:00 AM	2:00 AM	12:00 AM	2:00 AM	12:00 AM	12:00 AM	12:00 AM	12:00 AM	12:00 AM	12:00 AM	11:00 AM		
	35	12	130	144	9	1	0	1	0	0	0	0	0	0	325		
PM Peak Volume	12:00 PM	12:00 PM	2:00 PM	2:00 PM	2:00 PM	4:00 PM	12:00 PM	12:00 PM	12:00 PM	12:00 PM	12:00 PM	12:00 PM	12:00 PM	12:00 PM	2:00 PM		
	42	23	184	173	14	1	0	0	0	0	0	0	0	0	412		
<i>Comments:</i>																	

Report generated on 9/22/2023 2:43 PM

SOURCE: Quality Counts, LLC (<http://www.qualitycounts.net>)

Type of report: Tube Count - Speed Data

LOCATION: HWY 240 btwn Grant St and Main St															QC JOB #: 16302726		
SPECIFIC LOCATION:															DIRECTION: WB		
CITY/STATE: Newberg, OR															DATE: Sep 17 2023		
Start Time	1 15	16 20	21 25	26 30	31 35	36 40	41 45	46 50	51 55	56 60	61 65	66 70	71 75	76 999	Total	Pace Speed	Number in Pace
12:00 AM	2	1	10	22	2	0	0	0	0	0	0	0	0	0	37	21-30	32
01:00 AM	0	1	7	6	1	0	0	0	0	0	0	0	0	0	15	21-30	13
02:00 AM	0	0	2	9	2	0	0	0	0	0	0	0	0	0	13	22-31	11
03:00 AM	0	2	3	2	2	0	0	0	0	0	0	0	0	0	9	18-27	5
04:00 AM	0	0	7	4	0	0	0	0	0	0	0	0	0	0	11	21-30	11
05:00 AM	2	3	27	36	8	0	0	0	0	0	0	0	0	0	76	21-30	63
06:00 AM	0	3	42	65	14	0	0	0	0	0	0	0	0	0	124	21-30	107
07:00 AM	3	4	41	43	5	0	0	0	0	0	0	0	0	0	96	21-30	84
08:00 AM	3	3	59	79	4	0	0	0	0	0	0	0	0	0	148	21-30	138
09:00 AM	14	8	80	97	7	0	0	0	0	0	0	0	0	0	206	21-30	177
10:00 AM	15	6	91	128	7	0	0	0	0	0	0	0	0	0	247	21-30	219
11:00 AM	18	9	132	131	10	0	0	0	0	0	0	0	0	0	300	21-30	263
12:00 PM	32	11	122	141	8	0	0	0	0	0	0	0	0	0	314	21-30	263
01:00 PM	36	10	182	166	7	1	0	0	0	0	0	0	0	0	402	21-30	348
02:00 PM	23	5	150	141	9	1	0	0	0	0	0	0	0	0	329	21-30	291
03:00 PM	33	18	133	105	3	0	0	0	0	0	0	0	0	0	292	21-30	238
04:00 PM	24	7	149	108	5	0	0	0	0	0	0	0	0	0	293	21-30	257
05:00 PM	27	3	125	123	5	0	0	0	0	0	0	0	0	0	283	21-30	248
06:00 PM	14	11	124	88	5	0	0	0	0	0	0	0	0	0	242	21-30	212
07:00 PM	10	6	108	72	1	0	0	0	0	0	0	0	0	0	197	21-30	180
08:00 PM	2	5	92	59	5	0	0	0	0	0	0	0	0	0	163	21-30	151
09:00 PM	1	8	52	36	3	0	0	0	0	0	0	0	0	0	100	21-30	88
10:00 PM	0	3	18	19	0	1	0	0	0	0	0	0	0	0	41	21-30	37
11:00 PM	0	5	17	4	0	1	0	0	0	0	0	0	0	0	27	16-25	22
Day Total	259	132	1773	1684	113	4	0	0	0	0	0	0	0	0	3965	21-30	3457
Percent	6.5%	3.3%	44.7%	42.5%	2.8%	0.1%	0%	0%	0%	0%	0%	0%	0%	0%			
AM Peak Volume	11:00 AM 18	11:00 AM 9	11:00 AM 132	11:00 AM 131	6:00 AM 14	12:00 AM 0	12:00 AM 0	12:00 AM 0	12:00 AM 0	12:00 AM 0	12:00 AM 0	12:00 AM 0	12:00 AM 0	12:00 AM 0	11:00 AM 300		
PM Peak Volume	1:00 PM 36	3:00 PM 18	1:00 PM 182	1:00 PM 166	2:00 PM 9	1:00 PM 1	12:00 PM 0	12:00 PM 0	12:00 PM 0	12:00 PM 0	12:00 PM 0	12:00 PM 0	12:00 PM 0	12:00 PM 0	1:00 PM 402		
<i>Comments:</i>																	

Report generated on 9/22/2023 2:43 PM

SOURCE: Quality Counts, LLC (<http://www.qualitycounts.net>)

Type of report: Tube Count - Speed Data

LOCATION: HWY 240 btwn Grant St and Main St															QC JOB #: 16302726		
SPECIFIC LOCATION:															DIRECTION: WB		
CITY/STATE: Newberg, OR															DATE: Sep 18 2023		
Start Time	1 15	16 20	21 25	26 30	31 35	36 40	41 45	46 50	51 55	56 60	61 65	66 70	71 75	76 999	Total	Pace Speed	Number in Pace
12:00 AM	0	0	5	6	0	1	0	0	0	0	0	0	0	0	12	21-30	11
01:00 AM	0	4	7	4	1	0	0	0	0	0	0	0	0	0	16	19-28	11
02:00 AM	0	0	6	5	1	0	0	0	0	0	0	0	0	0	12	21-30	11
03:00 AM	0	1	13	12	1	0	0	0	0	0	0	0	0	0	27	21-30	25
04:00 AM	0	1	9	13	0	0	0	0	0	0	0	0	0	0	23	21-30	22
05:00 AM	9	4	62	55	7	0	0	0	0	0	0	0	0	0	137	21-30	117
06:00 AM	14	12	134	108	10	0	0	0	0	0	0	0	0	0	278	21-30	242
07:00 AM	33	16	115	102	4	0	0	0	0	0	0	0	0	0	270	21-30	217
08:00 AM	17	11	144	72	0	0	0	0	0	0	0	0	0	0	244	21-30	216
09:00 AM	32	12	122	67	2	0	0	0	0	0	0	0	0	0	235	21-30	189
10:00 AM	22	12	127	60	3	0	0	0	0	0	0	0	0	0	224	21-30	187
11:00 AM	32	14	130	62	3	0	0	0	0	0	0	0	0	0	241	21-30	192
12:00 PM	21	18	180	81	6	0	0	0	0	0	0	0	0	0	306	21-30	261
01:00 PM	23	23	166	87	2	0	0	0	0	0	0	0	0	0	301	21-30	253
02:00 PM	31	18	147	115	6	0	0	0	0	0	0	0	0	0	317	21-30	262
03:00 PM	48	13	179	189	10	1	0	0	0	0	0	0	0	0	440	21-30	368
04:00 PM	43	15	266	221	13	0	0	0	0	0	0	0	0	0	558	21-30	487
05:00 PM	39	11	245	217	6	1	0	0	0	0	0	0	0	0	519	21-30	462
06:00 PM	26	5	168	107	7	1	0	0	0	0	0	0	0	0	314	21-30	275
07:00 PM	16	19	93	69	7	0	0	0	0	0	0	0	0	0	204	21-30	162
08:00 PM	7	9	92	64	2	0	0	0	0	0	0	0	0	0	174	21-30	156
09:00 PM	2	4	67	30	2	0	0	0	0	0	0	0	0	0	105	21-30	97
10:00 PM	1	3	29	20	2	0	0	0	0	0	0	0	0	0	55	21-30	49
11:00 PM	0	1	9	12	2	0	0	0	0	0	0	0	0	0	24	21-30	21
Day Total	416	226	2515	1778	97	4	0	0	0	0	0	0	0	0	5036	21-30	4293
Percent	8.3%	4.5%	49.9%	35.3%	1.9%	0.1%	0%	0%	0%	0%	0%	0%	0%	0%			
AM Peak Volume	7:00 AM 33	7:00 AM 16	8:00 AM 144	6:00 AM 108	6:00 AM 10	12:00 AM 1	12:00 AM 0	12:00 AM 0	12:00 AM 0	12:00 AM 0	12:00 AM 0	12:00 AM 0	12:00 AM 0	12:00 AM 0	6:00 AM 278		
PM Peak Volume	3:00 PM 48	1:00 PM 23	4:00 PM 266	4:00 PM 221	4:00 PM 13	3:00 PM 1	12:00 PM 0	12:00 PM 0	12:00 PM 0	12:00 PM 0	12:00 PM 0	12:00 PM 0	12:00 PM 0	12:00 PM 0	4:00 PM 558		
<i>Comments:</i>																	

Report generated on 9/22/2023 2:43 PM

SOURCE: Quality Counts, LLC (<http://www.qualitycounts.net>)

LOCATION: HWY 240 btwn Grant St and Main St														QC JOB #: 16302726			
SPECIFIC LOCATION:														DIRECTION: WB			
CITY/STATE: Newberg, OR														DATE: Sep 12 2023 - Sep 18 2023			
Speed Range	1 15	16 20	21 25	26 30	31 35	36 40	41 45	46 50	51 55	56 60	61 65	66 70	71 75	76 999	Total	Pace Speed	Number in Pace
Grand Total	2658	1386	16766	13886	740	22	1	1	0	0	0	0	0	0	35460	21-30	30652
Percent	7.5%	3.9%	47.3%	39.2%	2.1%	0.1%	0%	0%	0%	0%	0%	0%	0%	0%			
Cumulative Percent	7.5%	11.4%	58.7%	97.8%	99.9%	100%	100%	100%	100%	100%	100%	100%	100%	100%			
ADT 5065															85th Percentile: 28 MPH Mean Speed(Average): 24 MPH Median: 24 MPH Mode: 23 MPH		
<i>Comments:</i>																	

Report generated on 9/22/2023 2:43 PM

SOURCE: Quality Counts, LLC (<http://www.qualitycounts.net>)

TRUE DATA TO IMPROVE MOBILITY

Attachment C

Crash Data

CITY OF NEWBERG, YAMHILL COUNTY

HILLSBORO-SILV HY at ILLINOIS ST CN, City of Newberg, Yamhill County, 01/01/2017 to 12/31/2021

1 - 2 of 2 Crash records shown.

SER#	S	D	M	P	R	J	S	W	DATE	CLASS	CITY STREET	INT-TYPE	SPCL USE																		
INVEST	E	A	U	I	C	O	DAY	DIST	FIRST STREET	RD CHAR	(MEDIAN)	INT-REL	OFFRD	WTHR	CRASH	TRLR QTY	MOVE														
RD DPT	E	L	G	N	H	R	TIME	FROM	SECOND STREET	DIRECT	LEGS	TRAF-	RNDBT	SURF	COLL	OWNER	FROM	PRTC	INJ	G	E	LICNS	PED								
UNLOC?	D	C	S	V	L	K	LAT	LONG	LRS	LOCTN	(#LANES)	CONTL	DRVWY	LIGHT	SVRTY	V#	TYPE	TO	P#	TYPE	SVRTY	E	X	RES	LOC	ERROR	ACT	EVENT	CAUSE		
01183	N	N	N	N	N	N	11/17/2018	16	HILLSBORO-SILV HY	INTER	3-LEG	N	N	CLR	O-1 L-TURN	01	NONE	TURN-L													
CITY							SA		ILLINOIS ST CN	CN		NONE	N	DRY	TURN		PRVTE	SE-W									000	010	00		
N							4P			01	0		N	DUSK	INJ		PSNGR CAR		01	DRVR	NONE	66	F	OR-Y		004,028,052	000			32,02,08	
N							45 18 21.07	-122 58 22.66	014000100S00																						
																	02	NONE	STRGHT												
																	PRVTE	NW-SE									000	001	00		
																	MTRCYCLE		01	DRVR	INJC	47	M	OR-Y		000	000	001	00		
00995	N	N	N	N	N	N	09/26/2018	16	HILLSBORO-SILV HY	INTER	3-LEG	N	N	CLR	O-1 L-TURN	01	NONE	9	TURN-L												
NONE							WE		ILLINOIS ST CN	CN		STOP SIGN	N	DRY	TURN		N/A	SE-W									000		00		
N							7P			01	0		N	DAY	PDO		PSNGR CAR		01	DRVR	NONE	00	Unk	UNK		000	000		00		
N							45 18 21.08	-122 58 22.66	014000100S00																						
																	02	NONE	9	STRGHT											
																	N/A	NW-SE									000		00		
																	PSNGR CAR		01	DRVR	NONE	00	Unk	UNK		000	000		00		

Disclaimer: The information contained in this report is compiled from individual driver and police crash reports submitted to the Oregon Department of Transportation as required in ORS 811.720. The Crash Analysis and Reporting Unit is committed to providing the highest quality crash data to customers. However, because submittal of crash report forms is the responsibility of the individual driver, the Crash Analysis and Reporting Unit can not guarantee that all qualifying crashes are represented nor can assurances be made that all details pertaining to a single crash are accurate. Note: Legislative changes to DMV's vehicle crash reporting requirement, effective 01/01/2004, may result in fewer property damage only crashes being eligible for inclusion in the Statewide Crash Data File.

CITY OF NEWBERG, YAMHILL COUNTY

HILLSBORO-SILV HY at ILLINOIS ST CN, City of Newberg, Yamhill County, 01/01/2017 to 12/31/2021

OREGON.. DEPARTMENT OF TRANSPORTATION - TRANSPORTATION DEVELOPMENT DIVISION
TRANSPORTATION DATA SECTION - CRASH ANAYLYSIS AND REPORTING UNIT
URBAN NON-SYSTEM CRASH LISTING

CITY OF NEWBERG, YAMHILL COUNTY

PINEHURST ST at HILLSBORO-SILV HY, City of Newberg, Yamhill County, 01/01/2017 to 12/31/2021

1 - 1 of 1 Crash records shown.

SER#	P	R	J	S	W	DATE	CLASS	CITY STREET	INT-TYPE	SPCL USE	A	S																	
INVEST	E	A	U	I	C	O	DIST	FIRST STREET	RD CHAR	(MEDIAN)	INT-REL	OFFRD	WTHR	CRASH	TRLR	QTY	MOVE	PRTC	INJ	G	E	LICNS	PED	ACT	EVENT	CAUSE			
RD DPT	E	L	G	N	H	R	TIME	SECOND STREET	DIRECT	LEGS	TRAF-	RNDBT	SURF	COLL	OWNER	FROM	TO	P#	TYPE	SVRTY	E	X	RES	LOC	ERROR	ACT	EVENT	CAUSE	
UNLOC?	D	C	S	V	L	K	LAT	LONG	LRS	LOCTN	(#LANES)	CONTL	DRVWY	LIGHT	SVRTY	V#	TYPE	TO	P#	TYPE	SVRTY	E	X	RES	LOC	ERROR	ACT	EVENT	CAUSE
01101	N	N	N	N			10/11/2017	16	HILLSBORO-SILV HY	INTER	CROSS	N	N	CLR	S-1STOP	01	NONE	0	STRGHT										
							WE		PINEHURST ST	N		STOP SIGN	N	DRY	REAR		PRVTE	N	-S							000		00	
N							4P			06	0		N	DAY	INJ		PSNGR CAR			01	DRVR	NONE	29	M	OR-Y		026	000	29
N							45 18 41.21	-122 58	014000100S00																				
							24.09																						

Disclaimer: The information contained in this report is compiled from individual driver and police crash reports submitted to the Oregon Department of Transportation as required in ORS 811.720. The Crash Analysis and Reporting Unit is committed to providing the highest quality crash data to customers. However, because submittal of crash report forms is the responsibility of the individual driver, the Crash Analysis and Reporting Unit can not guarantee that all qualifying crashes are represented nor can assurances be made that all details pertaining to a single crash are accurate. Note: Legislative changes to DMV's vehicle crash reporting requirement, effective 01/01/2004, may result in fewer property damage only crashes being eligible for inclusion in the Statewide Crash Data File.

CITY OF NEWBERG, YAMHILL COUNTY

PINEHURST ST at HILLSBORO-SILV HY, City of Newberg, Yamhill County, 01/01/2017 to 12/31/2021

CITY OF NEWBERG, YAMHILL COUNTY

HILLSBORO-SILV HY at DESKINS ST, City of Newberg, Yamhill County, 01/01/2017 to 12/31/2021

SER#	P	R	J	S	W	DATE	CLASS	CITY STREET	RD CHAR	INT-TYPE	SPCL USE	MOVE	A	S	RD DPT	E	L	G	N	H	R	TIME	FROM	SECOND STREET	DIRECT	LEGS	TRAF-	RNDBT	SURF	COLL	OWNER	FROM	PRTC	INJ	G	E	LICNS	PED	UNLOC?	D	C	S	V	L	K	LAT	LONG	LRS	LOCTN	(#LANES)	CONTL	DRVWY	LIGHT	SVRTY	V#	TYPE	TO	P#	TYPE	SVRTY	E	X	RES	LOC	ERROR	ACT	EVENT	CAUSE
------	---	---	---	---	---	------	-------	-------------	---------	----------	----------	------	---	---	--------	---	---	---	---	---	---	------	------	---------------	--------	------	-------	-------	------	------	-------	------	------	-----	---	---	-------	-----	--------	---	---	---	---	---	---	-----	------	-----	-------	----------	-------	-------	-------	-------	----	------	----	----	------	-------	---	---	-----	-----	-------	-----	-------	-------

Disclaimer: The information contained in this report is compiled from individual driver and police crash reports submitted to the Oregon Department of Transportation as required in ORS 811.720. The Crash Analysis and Reporting Unit is committed to providing the highest quality crash data to customers. However, because submittal of crash report forms is the responsibility of the individual driver, the Crash Analysis and Reporting Unit can not guarantee that all qualifying crashes are represented nor can assurances be made that all details pertaining to a single crash are accurate. Note: Legislative changes to DMV's vehicle crash reporting requirement, effective 01/01/2004, may result in fewer property damage only crashes being eligible for inclusion in the Statewide Crash Data File.

CITY OF NEWBERG, YAMHILL COUNTY

HILLSBORO-SILV HY at DESKINS ST, City of Newberg, Yamhill County, 01/01/2017 to 12/31/2021

CITY OF NEWBERG, YAMHILL COUNTY

ILLINOIS ST at DESKINS ST, City of Newberg, Yamhill County, 01/01/2017 to 12/31/2021

SER#	P	R	J	S	W	DATE	CLASS	CITY STREET	RD CHAR	INT-TYPE	SPCL USE	MOVE	A	S	RD DPT	E	L	G	N	H	R	TIME	FROM	SECOND STREET	DIRECT	LEGS	TRAF-	RNDBT	SURF	COLL	OWNER	FROM	PRTC	INJ	G	E	LICNS	PED	UNLOC?	D	C	S	V	L	K	LAT	LONG	LRS	LOCTN	(#LANES)	CONTL	DRVWY	LIGHT	SVRTY	V#	TYPE	TO	P#	TYPE	SVRTY	E	X	RES	LOC	ERROR	ACT	EVENT	CAUSE
------	---	---	---	---	---	------	-------	-------------	---------	----------	----------	------	---	---	--------	---	---	---	---	---	---	------	------	---------------	--------	------	-------	-------	------	------	-------	------	------	-----	---	---	-------	-----	--------	---	---	---	---	---	---	-----	------	-----	-------	----------	-------	-------	-------	-------	----	------	----	----	------	-------	---	---	-----	-----	-------	-----	-------	-------

Disclaimer: The information contained in this report is compiled from individual driver and police crash reports submitted to the Oregon Department of Transportation as required in ORS 811.720. The Crash Analysis and Reporting Unit is committed to providing the highest quality crash data to customers. However, because submittal of crash report forms is the responsibility of the individual driver, the Crash Analysis and Reporting Unit can not guarantee that all qualifying crashes are represented nor can assurances be made that all details pertaining to a single crash are accurate. Note: Legislative changes to DMV's vehicle crash reporting requirement, effective 01/01/2004, may result in fewer property damage only crashes being eligible for inclusion in the Statewide Crash Data File.

CITY OF NEWBERG, YAMHILL COUNTY

ILLINOIS ST at DESKINS ST, City of Newberg, Yamhill County, 01/01/2017 to 12/31/2021

CITY OF NEWBERG, YAMHILL COUNTY

MAIN ST at COLUMBIA ST, City of Newberg, Yamhill County, 01/01/2017 to 12/31/2021

SER#	P	R	J	S	W	DATE	CLASS	CITY STREET	INT-TYPE	SPCL USE	TRLR QTY	MOVE	A	S	RD DPT	E	L	G	N	H	R	TIME	FROM	SECOND STREET	DIRECT	LEGS	TRAF-	RNDBT	SURF	COLL	OWNER	FROM	PRTC	INJ	G	E	LICNS	PED	UNLOC?	D	C	S	V	L	K	LAT	LONG	LRS	LOCTN	(#LANES)	CONTL	DRVWY	LIGHT	SVRTY	V#	TYPE	TO	P#	TYPE	SVRTY	E	X	RES	LOC	ERROR	ACT	EVENT	CAUSE
------	---	---	---	---	---	------	-------	-------------	----------	----------	----------	------	---	---	--------	---	---	---	---	---	---	------	------	---------------	--------	------	-------	-------	------	------	-------	------	------	-----	---	---	-------	-----	--------	---	---	---	---	---	---	-----	------	-----	-------	----------	-------	-------	-------	-------	----	------	----	----	------	-------	---	---	-----	-----	-------	-----	-------	-------

Disclaimer: The information contained in this report is compiled from individual driver and police crash reports submitted to the Oregon Department of Transportation as required in ORS 811.720. The Crash Analysis and Reporting Unit is committed to providing the highest quality crash data to customers. However, because submittal of crash report forms is the responsibility of the individual driver, the Crash Analysis and Reporting Unit can not guarantee that all qualifying crashes are represented nor can assurances be made that all details pertaining to a single crash are accurate. Note: Legislative changes to DMV's vehicle crash reporting requirement, effective 01/01/2004, may result in fewer property damage only crashes being eligible for inclusion in the Statewide Crash Data File.

CITY OF NEWBERG, YAMHILL COUNTY

CITY OF NEWBERG, YAMHILL COUNTY

YAMHILL-NEWBERG HY at MAIN ST, City of Newberg, Yamhill County, 01/01/2017 to 12/31/2021

CITY OF NEWBERG, YAMHILL COUNTY

CITY OF NEWBERG, YAMHILL COUNTY

OREGON.. DEPARTMENT OF TRANSPORTATION - TRANSPORTATION DEVELOPMENT DIVISION
 TRANSPORTATION DATA SECTION - CRASH ANALYSIS AND REPORTING UNIT
 URBAN NON-SYSTEM CRASH LISTING
MAIN ST at NORTH ST, City of Newberg, Yamhill County, 01/01/2017 to 12/31/2021

CITY OF NEWBERG, YAMHILL COUNTY

SER#	P	R	J	S	W	DATE	CLASS	CITY STREET	RD CHAR	INT-TYPE	SPCL USE	TRLR QTY	MOVE	A	S	RD DPT	E	L	G	N	H	R	TIME	FROM	SECOND STREET	DIRECT	LEGS	TRAF-	RNDBT	SURF	COLL	OWNER	FROM	PRTC	INJ	G	E	LICNS	PED	UNLOC?	D	C	S	V	L	K	LAT	LONG	LRS	LOCTN	(#LANES)	CONTL	DRVWY	LIGHT	SVRTY	V#	TYPE	TO	P#	TYPE	SVRTY	E	X	RES	LOC	ERROR	ACT	EVENT	CAUSE
------	---	---	---	---	---	------	-------	-------------	---------	----------	----------	----------	------	---	---	--------	---	---	---	---	---	---	------	------	---------------	--------	------	-------	-------	------	------	-------	------	------	-----	---	---	-------	-----	--------	---	---	---	---	---	---	-----	------	-----	-------	----------	-------	-------	-------	-------	----	------	----	----	------	-------	---	---	-----	-----	-------	-----	-------	-------

Disclaimer: The information contained in this report is compiled from individual driver and police crash reports submitted to the Oregon Department of Transportation as required in ORS 811.720. The Crash Analysis and Reporting Unit is committed to providing the highest quality crash data to customers. However, because submittal of crash report forms is the responsibility of the individual driver, the Crash Analysis and Reporting Unit can not guarantee that all qualifying crashes are represented nor can assurances be made that all details pertaining to a single crash are accurate. Note: Legislative changes to DMV's vehicle crash reporting requirement, effective 01/01/2004, may result in fewer property damage only crashes being eligible for inclusion in the Statewide Crash Data File.

CITY OF NEWBERG, YAMHILL COUNTY

CITY OF NEWBERG, YAMHILL COUNTY

MAIN ST at PINEHURST CT, City of Newberg, Yamhill County, 01/01/2017 to 12/31/2021

SER#	P	R	J	S	W	DATE	CLASS	CITY STREET	INT-TYPE	SPCL USE	MOVE	A	S	RD DPT	E	L	G	N	H	R	TIME	FROM	SECOND STREET	DIRECT	LEGS	TRAF-	RNDBT	SURF	COLL	OWNER	FROM	PRTC	INJ	G	E	LICNS	PED	UNLOC?	D	C	S	V	L	K	LAT	LONG	LRS	LOCTN	(#LANES)	CONTL	DRVWY	LIGHT	SVRTY	V#	TYPE	TO	P#	TYPE	SVRTY	E	X	RES	LOC	ERROR	ACT	EVENT	CAUSE
------	---	---	---	---	---	------	-------	-------------	----------	----------	------	---	---	--------	---	---	---	---	---	---	------	------	---------------	--------	------	-------	-------	------	------	-------	------	------	-----	---	---	-------	-----	--------	---	---	---	---	---	---	-----	------	-----	-------	----------	-------	-------	-------	-------	----	------	----	----	------	-------	---	---	-----	-----	-------	-----	-------	-------

Disclaimer: The information contained in this report is compiled from individual driver and police crash reports submitted to the Oregon Department of Transportation as required in ORS 811.720. The Crash Analysis and Reporting Unit is committed to providing the highest quality crash data to customers. However, because submittal of crash report forms is the responsibility of the individual driver, the Crash Analysis and Reporting Unit can not guarantee that all qualifying crashes are represented nor can assurances be made that all details pertaining to a single crash are accurate. Note: Legislative changes to DMV's vehicle crash reporting requirement, effective 01/01/2004, may result in fewer property damage only crashes being eligible for inclusion in the Statewide Crash Data File.

CITY OF NEWBERG, YAMHILL COUNTY

CITY OF NEWBERG, YAMHILL COUNTY

ILLINOIS ST at WASHINGTON ST, City of Newberg, Yamhill County, 01/01/2017 to 12/31/2021

151: YAMHILL-NEWBERG

Highway 151 ALL ROAD TYPES, MP 11.04 to 11.22 01/01/2017 to 12/31/2021, Both Add and Non-Add mileage

151: YAMHILL-NEWBERG

Highway 151 ALL ROAD TYPES, MP 11.04 to 11.22 01/01/2017 to 12/31/2021, Both Add and Non-Add mileage

6 - 9 of 9 Crash records shown.

SER#	P	R	J	S	W	DATE	COUNTY	RD#	FC	CONN#	RD CHAR	INT-TYPE	SPCL USE	MOVE	A	S	ACT	EVENT	CAUSE												
INVEST	E	A	U	I	C	O	CITY	COMPNT	FIRST STREET	DIRECT	(MEDIAN)	INT-REL	OFFRD	WTHR	CRASH	TRLR QTY															
RD DPT	E	L	G	N	H	R	URBAN AREA	MLG	TYP	SECOND STREET	LOCTN	LEGS	TRAF-	RNDBT	SURF	COLL	OWNER	FROM	PRTC	INJ	G	E	LICNS	PED							
UNLOC?	D	C	S	V	L	K	LONG	MILEPNT	LRS		(#LANES)	CONTL	DRVWY	LIGHT	SVRTY	V#	TYPE	TO	P#	TYPE	SVRTY	E	X	RES	LOC	ERROR					
00671	Y	N	N	N	N	N	09/06/2020	YAMHILL	1	16	CURVE	N		Y	CLR	FIX OBJ	01	NONE	9	STRGHT									040,128	33,30	
CITY						SU	NEWBERG	MN	0	YAMHILL-NEWBERG HY	NW	(NONE)	UNKNOWN	N	DRY	FIX	N/A	SE-NW									088		00		
Y						3P	NEWBERG UA	11.14		MAIN ST	07			N	DAY	PDO		PSNGR CAR		01	DRVR	NONE	00	Unk	UNK		000	000		00	
N						45 18 19.99	-122 58 45.89			015100100S00		(02)																			
01414	N	N	N	N	N	N	12/22/2017	YAMHILL	1	16	INTER	3-LEG	N	N	RAIN	ANGL-OTH	01	NONE	9	STRGHT									128	02	
CITY						FR	NEWBERG	MN	0	MAIN ST	CN		STOP SIGN	N	WET	TURN	N/A	SE-NW									000		00		
N						6P	NEWBERG UA	11.15		YAMHILL-NEWBERG HY	01	0		N	DARK	PDO		PSNGR CAR		01	DRVR	NONE	00	Unk	UNK		000	000		00	
N						45 18 19.65	-122 58 45.28			015100100S00																					
																	02	NONE	9	TURN-L								000		00	
																	N/A	NE-SE		01	DRVR	NONE	00	Unk	UNK		000	000		00	
																	PSNGR CAR									000	000		00		
01217	N	N	N	N	N	N	11/21/2018	YAMHILL	1	16	STRGHT	Y		N	CLR	S-1STOP	01	NONE	9	STRGHT									07,29		
NONE						WE	NEWBERG	MN	0	YAMHILL-NEWBERG HY	S	(NONE)	STOP SIGN	N	UNK	REAR	N/A	S -N									000		00		
N						2P	NEWBERG UA	11.16		MAIN ST	04			N	DAY	PDO		PSNGR CAR		01	DRVR	NONE	00	Unk	UNK		000	000		00	
N						45 18 19.42	-122 58 44.98			015100100S00		(02)																			
																	02	NONE	9	STOP								011		00	
																	N/A	S -S		01	DRVR	NONE	00	Unk	UNK		000	000		00	
																	PSNGR CAR									000	000		00		
01043	N	Y	N	N	N	N	12/31/2020	YAMHILL	1	16	CURVE	N		N	CLR	O-STRGHT	01	NONE		STRGHT								128	33,05,10		
NO RPT						TH	NEWBERG	MN	0	MAIN ST	S	(NONE)	UNKNOWN	N	DRY	SS-M		PRVTE		N -S							000	128	00		
Y						6P	NEWBERG UA	11.17		ILLINOIS ST	08			N	DLIT	INJ		PSNGR CAR		01	DRVR	NONE	63	M	OR-Y		080	000		33,05,10	
N						45 18 19.12	-122 58 44.8			015100100S00		(02)																			
																	02	NONE		STRGHT											
																	PRVTE		S -N								000		00		
																	PSNGR CAR			01	DRVR	INJC	44	F	OR-Y		000	000		00	
																	02	NONE		STRGHT								000		00	
																	PRVTE		S -N									000		00	
																	PSNGR CAR			02	PSNG	INJC	43	M			000	000		00	

Disclaimer: The information contained in this report is compiled from individual driver and police crash reports submitted to the Oregon Department of Transportation as required in ORS 811.720. The Crash Analysis and Reporting Unit is committed to providing the highest quality crash data to customers. However, because submittal of crash report forms is the responsibility of the individual driver, the Crash Analysis and Reporting Unit can not guarantee that all qualifying crashes are represented nor can assurances be made that all details pertaining to a single crash are accurate. Note: Legislative changes to DMV's vehicle crash reporting requirement, effective 01/01/2004, may result in fewer property damage only crashes being eligible for inclusion in the Statewide Crash Data File.

151: YAMHILL-NEWBERG

Highway 151 ALL ROAD TYPES, MP 11.04 to 11.22 01/01/2017 to 12/31/2021, Both Add and Non-Add mileage

CITY OF NEWBERG, YAMHILL COUNTY

ILLINOIS ST and Intersectional Crashes at ILLINOIS ST, City of Newberg, Yamhill County, 01/01/2017 to 12/31/2021

CITY OF NEWBERG, YAMHILL COUNTY

ILLINOIS ST and Intersectional Crashes at ILLINOIS ST, City of Newberg, Yamhill County, 01/01/2017 to 12/31/2021

CITY OF NEWBERG, YAMHILL COUNTY

MAIN ST and Intersectional Crashes at MAIN ST, City of Newberg, Yamhill County, 01/01/2017 to 12/31/2021

CITY OF NEWBERG, YAMHILL COUNTY

MAIN ST and Intersectional Crashes at MAIN ST, City of Newberg, Yamhill County, 01/01/2017 to 12/31/2021

CITY OF NEWBERG, YAMHILL COUNTY

MAIN ST and Intersectional Crashes at MAIN ST, City of Newberg, Yamhill County, 01/01/2017 to 12/31/2021

CITY OF NEWBERG, YAMHILL COUNTY

MAIN ST and Intersectional Crashes at MAIN ST, City of Newberg, Yamhill County, 01/01/2017 to 12/31/2021

CITY OF NEWBERG, YAMHILL COUNTY

MAIN ST and Intersectional Crashes at MAIN ST, City of Newberg, Yamhill County, 01/01/2017 to 12/31/2021

CITY OF NEWBERG, YAMHILL COUNTY

MAIN ST and Intersectional Crashes at MAIN ST, City of Newberg, Yamhill County, 01/01/2017 to 12/31/2021

CITY OF NEWBERG, YAMHILL COUNTY

MAIN ST and Intersectional Crashes at MAIN ST, City of Newberg, Yamhill County, 01/01/2017 to 12/31/2021

CITY OF NEWBERG, YAMHILL COUNTY

MAIN ST and Intersectional Crashes at MAIN ST, City of Newberg, Yamhill County, 01/01/2017 to 12/31/2021

OREGON.. DEPARTMENT OF TRANSPORTATION - TRANSPORTATION DEVELOPMENT DIVISION
TRANSPORTATION DATA SECTION - CRASH ANALYSIS AND REPORTING UNIT
URBAN NON-SYSTEM CRASH LISTING

CITY OF NEWBERG, YAMHILL COUNTY

MAIN ST and Intersectional Crashes at MAIN ST, City of Newberg, Yamhill County, 01/01/2017 to 12/31/2021

38 - 41 of 49 Crash records shown.

SER#	S P R J S W DATE	CLASS	CITY STREET	INT-TYPE	SPCL USE	MOVE	A S	ACT	EVENT	CAUSE											
INVEST	E A U I C O DAY	DIST	FIRST STREET	RD CHAR	(MEDIAN) INT-REL	OFFRD WTHR	CRASH	TRLR QTY	MOVE	A S											
RD DPT	E L G N H R TIME	FROM	SECOND STREET	DIRECT	LEGS TRAF-	RNDBT SURF	COLL	OWNER	FROM	PRTC INJ	G E LICNS	PED	ERROR	ACT	EVENT	CAUSE					
UNLOC?	D C S V L K LAT	LONG	LRS	LOCTN	(#LANES) CONTL	DRVWY LIGHT	SVRTY	V# TYPE	TO	P# TYPE SVRTY	E X RES	LOC	ERROR	ACT	EVENT	CAUSE					
00461	NNNN	05/14/2019	14	MAIN ST	INTER	CROSS	N	N	CLD	ANGL-OTH	01 NONE	STRGHT				04					
CITY	TU			1ST ST	CN		TRF SIGNAL	N	DRY	ANGL	PRVTE	W -E			000	00					
N	4P				03	0		N	DAY	INJ	PSNGR CAR		01 DRVR	INJC	52 F	OR-Y OR<25	003	000	04		
N	45 18 1.2	-122 58 45.09	009100200S00								02 NONE	STRGHT									
											PRVTE	N -S		01 DRVR	INJC	32 M	OR-Y OR<25	000	000	00	
											PSNGR CAR									00	
											03 NONE	STRGHT		01 DRVR	INJC	30 F	OR-Y OR<25	000	000	00	
											PRVTE	S -N								00	
											PSNGR CAR									00	
00884	NNNN	09/11/2019	14	MAIN ST	INTER	CROSS	N	N	CLR	ANGL-OTH	01 NONE	STRGHT				04					
CITY	WE			1ST ST	CN		TRF SIGNAL	N	DRY	ANGL	PRVTE	W -E				000	00				
N	1P				04	0		N	DAY	INJ	PSNGR CAR		01 DRVR	INJB	66 F	OR-Y OR<25	020	000	04		
N	45 18 1.16	-122 58 45.07	009100200S00								02 NONE	STRGHT									
											PRVTE	S -N		01 DRVR	INJC	36 F	OR-Y OR>25	000	000	00	
											PSNGR CAR									00	
00021	NNNN	01/10/2020	14	MAIN ST	INTER	CROSS	N	N	RAIN	BIKE	01 NONE	TURN-L				02,40					
CITY	FR			1ST ST	CN		TRF SIGNAL	N	WET	ANGL	PRVTE	N -E				000	00				
N	3P				02	0		N	DAY	INJ	PSNGR CAR		01 DRVR	NONE	32 F	OR-Y OR>25	027	000	02,40		
N	45 18 1.18	-122 58 45.07	009100200S00																		
											-	STRGHT		01 BIKE	INJC	56 F		I XWLK	000	000	00
												N S									
00732	NNNNNN	09/24/2020	14	MAIN ST	INTER	CROSS	N	N	CLR	O-1 L-TURN	01 NONE	STRGHT				02					
CITY	TH			1ST ST	CN		TRF SIGNAL	N	DRY	TURN	PRVTE	S -N				000	00				
N	8P				02	0		N	DUSK	INJ	PSNGR CAR		01 DRVR	INJC	66 F	OR-Y OR<25	000	000	00		
N	45 18 1.16	-122 58 45.08	009100200S00								02 NONE	TURN-L									
											PRVTE	N -E		01 DRVR	INJB	16 F	OR-Y OR<25	004,028	000	02	
											PSNGR CAR										
00826	NNNNNN	10/19/2020	14	MAIN ST	INTER	CROSS	N	N	CLD	ANGL-OTH	01 NONE	STRGHT				04,27					
CITY	MO			1ST ST	CN		TRF SIGNAL	N	DRY	ANGL	PRVTE	W -E				000	00				
N	5P				04	0		N	DAY	INJ	PSNGR CAR		01 DRVR	INJC	42 F	OR-Y OR<25	020	000	04,27		
N	45 18 1.17	-122 58 45.08	009100200S00																		

Disclaimer: The information contained in this report is compiled from individual driver and police crash reports submitted to the Oregon Department of Transportation as required in ORS 811.720. The Crash Analysis and Reporting Unit is committed to providing the highest quality crash data to customers. However, because submittal of crash report forms is the responsibility of the individual driver, the Crash Analysis and Reporting Unit can not guarantee that all qualifying crashes are represented nor can assurances be made that all details pertaining to a single crash are accurate. Note: Legislative changes to DMV's vehicle crash reporting requirement, effective 01/01/2004, may result in fewer property damage only crashes being eligible for inclusion in the Statewide Crash Data File.

CITY OF NEWBERG, YAMHILL COUNTY

MAIN ST and Intersectional Crashes at MAIN ST, City of Newberg, Yamhill County, 01/01/2017 to 12/31/2021

CITY OF NEWBERG, YAMHILL COUNTY

MAIN ST and Intersectional Crashes at MAIN ST, City of Newberg, Yamhill County, 01/01/2017 to 12/31/2021

CITY OF NEWBERG, YAMHILL COUNTY

MAIN ST and Intersectional Crashes at MAIN ST, City of Newberg, Yamhill County, 01/01/2017 to 12/31/2021

















CITY OF NEWBERG, YAMHILL COUNTY

PINEHURST ST and Intersectional Crashes at PINEHURST ST, City of Newberg, Yamhill County, 01/01/2017 to 12/31/2021

Attachment D
Existing Year 2023 Traffic
Operational Worksheets

HCM Unsignalized Intersection Capacity Analysis
 101: N Main St & E Columbia Dr

Existing Peak Hour AM
 Existing AM 2023

												
Movement	EBL	EBT	EBR	WBL	WBT	WBR	NBL	NBT	NBR	SBL	SBT	SBR
Lane Configurations												
Sign Control		Stop			Stop			Stop			Stop	
Traffic Volume (vph)	2	15	10	12	8	10	5	68	23	7	64	3
Future Volume (vph)	2	15	10	12	8	10	5	68	23	7	64	3
Peak Hour Factor	0.79	0.79	0.79	0.79	0.79	0.79	0.79	0.79	0.79	0.79	0.79	0.79
Hourly flow rate (vph)	3	19	13	15	10	13	6	86	29	9	81	4
Direction, Lane #	EB 1	WB 1	NB 1	SB 1								
Volume Total (vph)	35	38	121	94								
Volume Left (vph)	3	15	6	9								
Volume Right (vph)	13	13	29	4								
Hadj (s)	-0.07	-0.01	-0.01	0.07								
Departure Headway (s)	4.4	4.4	4.2	4.3								
Degree Utilization, x	0.04	0.05	0.14	0.11								
Capacity (veh/h)	783	766	841	825								
Control Delay (s)	7.5	7.6	7.8	7.8								
Approach Delay (s)	7.5	7.6	7.8	7.8								
Approach LOS	A	A	A	A								
Intersection Summary												
Delay			7.8									
Level of Service			A									
Intersection Capacity Utilization			18.8%	ICU Level of Service	A							
Analysis Period (min)			15									

Intersection	
Intersection Delay, s/veh	7.8
Intersection LOS	A

















Movement	EBL	EBT	EBR	WBL	WBT	WBR	NBL	NBT	NBR	SBL	SBT	SBR
Lane Configurations		↕			↕			↕			↕	
Traffic Vol, veh/h	2	15	10	12	8	10	5	68	23	7	64	3
Future Vol, veh/h	2	15	10	12	8	10	5	68	23	7	64	3
Peak Hour Factor	0.79	0.79	0.79	0.79	0.79	0.79	0.79	0.79	0.79	0.79	0.79	0.79
Heavy Vehicles, %	50	7	0	8	0	10	0	7	9	0	5	0
Mvmt Flow	3	19	13	15	10	13	6	86	29	9	81	4
Number of Lanes	0	1	0	0	1	0	0	1	0	0	1	0

Approach	EB	WB	NB	SB
Opposing Approach	WB	EB	SB	NB
Opposing Lanes	1	1	1	1
Conflicting Approach Left	SB	NB	EB	WB
Conflicting Lanes Left	1	1	1	1
Conflicting Approach Right	NB	SB	WB	EB
Conflicting Lanes Right	1	1	1	1
HCM Control Delay	8.3	7.6	7.7	7.7
HCM LOS	A	A	A	A

Lane	NBLn1	EBLn1	WBLn1	SBLn1
Vol Left, %	5%	7%	40%	9%
Vol Thru, %	71%	56%	27%	86%
Vol Right, %	24%	37%	33%	4%
Sign Control	Stop	Stop	Stop	Stop
Traffic Vol by Lane	96	27	30	74
LT Vol	5	2	12	7
Through Vol	68	15	8	64
RT Vol	23	10	10	3
Lane Flow Rate	122	34	38	94
Geometry Grp	1	1	1	1
Degree of Util (X)	0.134	0.048	0.047	0.107
Departure Headway (Hd)	3.963	5.051	4.423	4.112
Convergence, Y/N	Yes	Yes	Yes	Yes
Cap	892	713	814	859
Service Time	2.045	3.053	2.424	2.197
HCM Lane V/C Ratio	0.137	0.048	0.047	0.109
HCM Control Delay	7.7	8.3	7.6	7.7
HCM Lane LOS	A	A	A	A
HCM 95th-tile Q	0.5	0.2	0.1	0.4

HCM Unsignalized Intersection Capacity Analysis
102: N Main St & W Pinehurst Ct/E Pinehurst Dr

Existing Peak Hour AM
Existing AM 2023

												
Movement	EBL	EBT	EBR	WBL	WBT	WBR	NBL	NBT	NBR	SBL	SBT	SBR
Lane Configurations												
Traffic Volume (veh/h)	1	5	0	7	0	6	0	87	9	12	74	0
Future Volume (Veh/h)	1	5	0	7	0	6	0	87	9	12	74	0
Sign Control		Stop			Stop			Free			Free	
Grade		0%			0%			0%			0%	
Peak Hour Factor	0.84	0.84	0.84	0.84	0.84	0.84	0.84	0.84	0.84	0.84	0.84	0.84
Hourly flow rate (vph)	1	6	0	8	0	7	0	104	11	14	88	0
Pedestrians		2										
Lane Width (ft)		12.0										
Walking Speed (ft/s)		3.5										
Percent Blockage		0										
Right turn flare (veh)												
Median type								None			None	
Median storage (veh)												
Upstream signal (ft)												
pX, platoon unblocked												
vC, conflicting volume	234	233	90	228	228	110	90			115		
vC1, stage 1 conf vol												
vC2, stage 2 conf vol												
vCu, unblocked vol	234	233	90	228	228	110	90			115		
tC, single (s)	7.1	6.5	6.2	7.2	6.5	6.2	4.1			4.1		
tC, 2 stage (s)												
tF (s)	3.5	4.0	3.3	3.6	4.0	3.3	2.2			2.2		
p0 queue free %	100	99	100	99	100	99	100			99		
cM capacity (veh/h)	711	663	971	691	668	950	1515			1487		
Direction, Lane #	EB 1	WB 1	NB 1	SB 1								
Volume Total	7	15	115	102								
Volume Left	1	8	0	14								
Volume Right	0	7	11	0								
cSH	670	792	1515	1487								
Volume to Capacity	0.01	0.02	0.00	0.01								
Queue Length 95th (ft)	1	1	0	1								
Control Delay (s)	10.4	9.6	0.0	1.1								
Lane LOS	B	A		A								
Approach Delay (s)	10.4	9.6	0.0	1.1								
Approach LOS	B	A										
Intersection Summary												
Average Delay			1.4									
Intersection Capacity Utilization			21.4%		ICU Level of Service				A			
Analysis Period (min)			15									

Intersection												
Int Delay, s/veh	1.4											
Movement	EBL	EBT	EBR	WBL	WBT	WBR	NBL	NBT	NBR	SBL	SBT	SBR
Lane Configurations		↕			↕			↕			↕	
Traffic Vol, veh/h	1	5	0	7	0	6	0	87	9	12	74	0
Future Vol, veh/h	1	5	0	7	0	6	0	87	9	12	74	0
Conflicting Peds, #/hr	0	0	0	0	0	0	2	0	0	0	0	2
Sign Control	Stop	Stop	Stop	Stop	Stop	Stop	Free	Free	Free	Free	Free	Free
RT Channelized	-	-	None	-	-	None	-	-	None	-	-	None
Storage Length	-	-	-	-	-	-	-	-	-	-	-	-
Veh in Median Storage, #	-	0	-	-	0	-	-	0	-	-	0	-
Grade, %	-	0	-	-	0	-	-	0	-	-	0	-
Peak Hour Factor	84	84	84	84	84	84	84	84	84	84	84	84
Heavy Vehicles, %	0	0	0	14	0	0	0	7	11	0	7	0
Mvmt Flow	1	6	0	8	0	7	0	104	11	14	88	0

















Major/Minor	Minor2		Minor1			Major1			Major2			
Conflicting Flow All	231	233	90	229	228	110	90	0	0	115	0	0
Stage 1	118	118	-	110	110	-	-	-	-	-	-	-
Stage 2	113	115	-	119	118	-	-	-	-	-	-	-
Critical Hdwy	7.1	6.5	6.2	7.24	6.5	6.2	4.1	-	-	4.1	-	-
Critical Hdwy Stg 1	6.1	5.5	-	6.24	5.5	-	-	-	-	-	-	-
Critical Hdwy Stg 2	6.1	5.5	-	6.24	5.5	-	-	-	-	-	-	-
Follow-up Hdwy	3.5	4	3.3	3.626	4	3.3	2.2	-	-	2.2	-	-
Pot Cap-1 Maneuver	728	671	973	701	675	949	1518	-	-	1487	-	-
Stage 1	891	802	-	867	808	-	-	-	-	-	-	-
Stage 2	897	804	-	857	802	-	-	-	-	-	-	-
Platoon blocked, %								-	-	-	-	-
Mov Cap-1 Maneuver	716	663	971	691	667	949	1515	-	-	1487	-	-
Mov Cap-2 Maneuver	716	663	-	691	667	-	-	-	-	-	-	-
Stage 1	889	792	-	867	808	-	-	-	-	-	-	-
Stage 2	890	804	-	842	792	-	-	-	-	-	-	-

Approach	EB		WB			NB			SB		
HCM Control Delay, s	10.4		9.6			0			1		
HCM LOS	B		A								

Minor Lane/Major Mvmt	NBL	NBT	NBR	EBLn1	WBLn1	SBL	SBT	SBR
Capacity (veh/h)	1515	-	-	671	790	1487	-	-
HCM Lane V/C Ratio	-	-	-	0.011	0.02	0.01	-	-
HCM Control Delay (s)	0	-	-	10.4	9.6	7.4	0	-
HCM Lane LOS	A	-	-	B	A	A	A	-
HCM 95th %tile Q(veh)	0	-	-	0	0.1	0	-	-

HCM Unsignalized Intersection Capacity Analysis
 103: N College St (Hwy 219) & E Pinehurst Dr

Existing Peak Hour AM
 Existing AM 2023

												
Movement	EBL	EBT	EBR	WBL	WBT	WBR	NBL	NBT	NBR	SBL	SBT	SBR
Lane Configurations												
Traffic Volume (veh/h)	0	0	0	0	0	0	0	0	0	0	0	0
Future Volume (Veh/h)	0	0	0	0	0	0	0	0	0	0	0	0
Sign Control		Stop			Stop			Free			Free	
Grade		0%			0%			0%			0%	
Peak Hour Factor	0.25	0.25	0.25	0.25	0.25	0.25	0.25	0.25	0.25	0.25	0.25	0.25
Hourly flow rate (vph)	0	0	0	0	0	0	0	0	0	0	0	0
Pedestrians												
Lane Width (ft)												
Walking Speed (ft/s)												
Percent Blockage												
Right turn flare (veh)												
Median type								None			None	
Median storage (veh)												
Upstream signal (ft)												
pX, platoon unblocked												
vC, conflicting volume	0	0	0	0	0	0	0			0		
vC1, stage 1 conf vol												
vC2, stage 2 conf vol												
vCu, unblocked vol	0	0	0	0	0	0	0			0		
tC, single (s)	7.1	6.5	6.2	7.1	6.5	6.2	4.1			4.1		
tC, 2 stage (s)												
tF (s)	3.5	4.0	3.3	3.5	4.0	3.3	2.2			2.2		
p0 queue free %	100	100	100	100	100	100	100			100		
cM capacity (veh/h)	1029	900	1091	1029	900	1091	1636			1636		
Direction, Lane #	EB 1	WB 1	NB 1	SB 1								
Volume Total	0	0	0	0								
Volume Left	0	0	0	0								
Volume Right	0	0	0	0								
cSH	1700	1700	1700	1700								
Volume to Capacity	0.07	0.03	0.00	0.00								
Queue Length 95th (ft)	0	0	0	0								
Control Delay (s)	0.0	0.0	0.0	0.0								
Lane LOS	A	A										
Approach Delay (s)	0.0	0.0	0.0	0.0								
Approach LOS	A	A										
Intersection Summary												
Average Delay			0.0									
Intersection Capacity Utilization			0.0%		ICU Level of Service					A		
Analysis Period (min)			15									

Intersection												
Int Delay, s/veh	0											
Movement	EBL	EBT	EBR	WBL	WBT	WBR	NBL	NBT	NBR	SBL	SBT	SBR
Lane Configurations		↕			↕			↕			↕	
Traffic Vol, veh/h	0	0	0	0	0	0	0	0	0	0	0	0
Future Vol, veh/h	0	0	0	0	0	0	0	0	0	0	0	0
Conflicting Peds, #/hr	0	0	0	0	0	0	0	0	0	0	0	0
Sign Control	Stop	Stop	Stop	Stop	Stop	Stop	Free	Free	Free	Free	Free	Free
RT Channelized	-	-	None	-	-	None	-	-	None	-	-	None
Storage Length	-	-	-	-	-	-	-	-	-	-	-	-
Veh in Median Storage, #	-	0	-	-	0	-	-	0	-	-	0	-
Grade, %	-	0	-	-	0	-	-	0	-	-	0	-
Peak Hour Factor	25	25	25	25	25	25	25	25	25	25	25	25
Heavy Vehicles, %	0	0	0	0	0	0	0	0	0	0	0	0
Mvmt Flow	0	0	0	0	0	0	0	0	0	0	0	0

Major/Minor	Minor2		Minor1		Major1		Major2					
Conflicting Flow All	4	4	4	4	4	0	4	0	0	0	0	0
Stage 1	4	4	-	0	0	-	-	-	-	-	-	-
Stage 2	0	0	-	4	4	-	-	-	-	-	-	-
Critical Hdwy	7.1	6.5	6.2	7.1	6.5	6.2	4.1	-	-	4.1	-	-
Critical Hdwy Stg 1	6.1	5.5	-	6.1	5.5	-	-	-	-	-	-	-
Critical Hdwy Stg 2	6.1	5.5	-	6.1	5.5	-	-	-	-	-	-	-
Follow-up Hdwy	3.5	4	3.3	3.5	4	3.3	2.2	-	-	2.2	-	-
Pot Cap-1 Maneuver	1022	896	1085	1022	896	-	1631	-	-	-	-	-
Stage 1	1024	897	-	-	-	-	-	-	-	-	-	-
Stage 2	-	-	-	1024	897	-	-	-	-	-	-	-
Platoon blocked, %	-	-	-	-	-	-	-	-	-	-	-	-
Mov Cap-1 Maneuver	-	896	1085	1022	896	-	1631	-	-	-	-	-
Mov Cap-2 Maneuver	-	896	-	1022	896	-	-	-	-	-	-	-
Stage 1	1024	897	-	-	-	-	-	-	-	-	-	-
Stage 2	-	-	-	1024	897	-	-	-	-	-	-	-

Approach	EB		WB		NB		SB	
HCM Control Delay, s	0		0		0		0	
HCM LOS	A		A					

Minor Lane/Major Mvmt	NBL	NBT	NBR	EBLn1	WBLn1	SBL	SBT	SBR
Capacity (veh/h)	1631	-	-	-	-	-	-	-
HCM Lane V/C Ratio	-	-	-	-	-	-	-	-
HCM Control Delay (s)	0	-	-	0	0	0	-	-
HCM Lane LOS	A	-	-	A	A	A	-	-
HCM 95th %tile Q(veh)	0	-	-	-	-	-	-	-

Intersection						
Int Delay, s/veh	4.4					
Movement	SEL	SET	NWT	NWR	SWL	SWR
Lane Configurations						
Traffic Vol, veh/h	92	394	295	80	84	45
Future Vol, veh/h	92	394	295	80	84	45
Conflicting Peds, #/hr	1	0	0	1	0	0
Sign Control	Free	Free	Free	Free	Stop	Stop
RT Channelized	-	None	-	None	-	None
Storage Length	75	-	-	-	0	-
Veh in Median Storage, #	-	0	0	-	0	-
Grade, %	-	0	0	-	0	-
Peak Hour Factor	88	88	88	88	88	88
Heavy Vehicles, %	4	9	15	9	2	2
Mvmt Flow	105	448	335	91	95	51

Major/Minor	Major1	Major2	Minor2		
Conflicting Flow All	427	0	-	0	1040 382
Stage 1	-	-	-	-	382 -
Stage 2	-	-	-	-	658 -
Critical Hdwy	4.14	-	-	-	6.42 6.22
Critical Hdwy Stg 1	-	-	-	-	5.42 -
Critical Hdwy Stg 2	-	-	-	-	5.42 -
Follow-up Hdwy	2.236	-	-	-	3.518 3.318
Pot Cap-1 Maneuver	1122	-	-	-	255 665
Stage 1	-	-	-	-	690 -
Stage 2	-	-	-	-	515 -
Platoon blocked, %		-	-	-	
Mov Cap-1 Maneuver	1121	-	-	-	231 664
Mov Cap-2 Maneuver	-	-	-	-	231 -
Stage 1	-	-	-	-	624 -
Stage 2	-	-	-	-	514 -

Approach	SE	NW	SW
HCM Control Delay, s	1.6	0	28.1
HCM LOS			D

Minor Lane/Major Mvmt	NWT	NWR	SEL	SETSWLn1
Capacity (veh/h)	-	-	1121	- 299
HCM Lane V/C Ratio	-	-	0.093	- 0.49
HCM Control Delay (s)	-	-	8.5	- 28.1
HCM Lane LOS	-	-	A	- D
HCM 95th %tile Q(veh)	-	-	0.3	- 2.5

HCM Unsignalized Intersection Capacity Analysis
105: E Illinois St & N Main St

Existing Peak Hour AM
Existing AM 2023



Movement	EBL	EBR	NBL	NBT	SBT	SBR
Lane Configurations						
Traffic Volume (veh/h)	65	106	64	10	34	63
Future Volume (Veh/h)	65	106	64	10	34	63
Sign Control	Free			Stop	Stop	
Grade	0%			0%	0%	
Peak Hour Factor	0.75	0.75	0.75	0.75	0.75	0.75
Hourly flow rate (vph)	87	141	85	13	45	84
Pedestrians	3			3	3	
Lane Width (ft)	12.0			12.0	12.0	
Walking Speed (ft/s)	3.5			3.5	3.5	
Percent Blockage	0			0	0	
Right turn flare (veh)						
Median type	None					
Median storage (veh)						
Upstream signal (ft)						
pX, platoon unblocked						
vC, conflicting volume	3		357	250	321	6
vC1, stage 1 conf vol						
vC2, stage 2 conf vol						
vCu, unblocked vol	3		357	250	321	6
tC, single (s)	4.2		7.1	6.5	6.5	6.3
tC, 2 stage (s)						
tF (s)	2.3		3.5	4.0	4.0	3.4
p0 queue free %	94		83	98	92	92
cM capacity (veh/h)	1576		490	616	563	1053
Direction, Lane #	EB 1	NB 1	SB 1			
Volume Total	228	98	129			
Volume Left	87	85	0			
Volume Right	141	0	84			
cSH	1576	504	808			
Volume to Capacity	0.06	0.19	0.16			
Queue Length 95th (ft)	4	18	14			
Control Delay (s)	3.1	13.9	10.3			
Lane LOS	A	B	B			
Approach Delay (s)	3.1	13.9	10.3			
Approach LOS		B	B			
Intersection Summary						
Average Delay			7.5			
Intersection Capacity Utilization			28.0%	ICU Level of Service	A	
Analysis Period (min)			15			

HCM Unsignalized Intersection Capacity Analysis
106: N Washington St & E Illinois St

Existing Peak Hour AM
Existing AM 2023

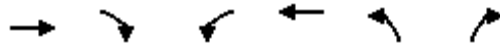

Movement	EBT	EBR	WBL	WBT	NBL	NBR
Lane Configurations	→			←	↔	↔
Traffic Volume (veh/h)	134	8	12	79	3	14
Future Volume (Veh/h)	134	8	12	79	3	14
Sign Control	Free			Free	Stop	
Grade	0%			0%	0%	
Peak Hour Factor	0.78	0.78	0.78	0.78	0.78	0.78
Hourly flow rate (vph)	172	10	15	101	4	18
Pedestrians						1
Lane Width (ft)						12.0
Walking Speed (ft/s)						3.5
Percent Blockage						0
Right turn flare (veh)						
Median type	None			None		
Median storage (veh)						
Upstream signal (ft)						
pX, platoon unblocked						
vC, conflicting volume			183			178
vC1, stage 1 conf vol						
vC2, stage 2 conf vol						
vCu, unblocked vol			183			178
tC, single (s)			4.2			6.4
tC, 2 stage (s)						
tF (s)			2.3			3.5
p0 queue free %			99			98
cM capacity (veh/h)			1355			817
Direction, Lane #	EB 1	WB 1	NB 1			
Volume Total	182	116	22			
Volume Left	0	15	4			
Volume Right	10	0	18			
cSH	1700	1355	788			
Volume to Capacity	0.11	0.01	0.03			
Queue Length 95th (ft)	0	1	2			
Control Delay (s)	0.0	1.1	9.7			
Lane LOS			A			
Approach Delay (s)	0.0	1.1	9.7			
Approach LOS			A			
Intersection Summary						
Average Delay			1.1			
Intersection Capacity Utilization			24.3%	ICU Level of Service	A	
Analysis Period (min)			15			

Intersection						
Int Delay, s/veh	1					
Movement	EBT	EBR	WBL	WBT	NBL	NBR
Lane Configurations						
Traffic Vol, veh/h	134	8	12	79	3	14
Future Vol, veh/h	134	8	12	79	3	14
Conflicting Peds, #/hr	0	1	1	0	0	0
Sign Control	Free	Free	Free	Free	Stop	Stop
RT Channelized	-	None	-	None	-	None
Storage Length	-	-	-	-	0	-
Veh in Median Storage, #	0	-	-	0	0	-
Grade, %	0	-	-	0	0	-
Peak Hour Factor	78	78	78	78	78	78
Heavy Vehicles, %	11	0	8	6	0	21
Mvmt Flow	172	10	15	101	4	18

Major/Minor	Major1	Major2	Minor1		
Conflicting Flow All	0	0	183	0	309
Stage 1	-	-	-	-	178
Stage 2	-	-	-	-	131
Critical Hdwy	-	-	4.18	-	6.4
Critical Hdwy Stg 1	-	-	-	-	5.4
Critical Hdwy Stg 2	-	-	-	-	5.4
Follow-up Hdwy	-	-	2.272	-	3.5
Pot Cap-1 Maneuver	-	-	1357	-	687
Stage 1	-	-	-	-	858
Stage 2	-	-	-	-	900
Platoon blocked, %	-	-	-	-	-
Mov Cap-1 Maneuver	-	-	1356	-	678
Mov Cap-2 Maneuver	-	-	-	-	678
Stage 1	-	-	-	-	857
Stage 2	-	-	-	-	889

Approach	EB	WB	NB
HCM Control Delay, s	0	1	9.7
HCM LOS			A

Minor Lane/Major Mvmt	NBLn1	EBT	EBR	WBL	WBT
Capacity (veh/h)	788	-	-	1356	-
HCM Lane V/C Ratio	0.028	-	-	0.011	-
HCM Control Delay (s)	9.7	-	-	7.7	0
HCM Lane LOS	A	-	-	A	A
HCM 95th %tile Q(veh)	0.1	-	-	0	-

Intersection						
Int Delay, s/veh	0.2					
Movement	EBL	EBR	NBL	NBT	SBT	SBR
Lane Configurations	↶	↷		↶	↷	
Traffic Vol, veh/h	8	0	1	314	377	65
Future Vol, veh/h	8	0	1	314	377	65
Conflicting Peds, #/hr	0	0	0	0	0	0
Sign Control	Stop	Stop	Free	Free	Free	Free
RT Channelized	-	Stop	-	None	-	None
Storage Length	0	50	-	-	-	-
Veh in Median Storage, #	0	-	-	0	0	-
Grade, %	0	-	-	0	0	-
Peak Hour Factor	87	87	87	87	87	87
Heavy Vehicles, %	9	0	2	2	0	4
Mvmt Flow	9	0	1	361	433	75

Major/Minor	Minor2	Major1	Major2			
Conflicting Flow All	834	471	508	0	-	0
Stage 1	471	-	-	-	-	-
Stage 2	363	-	-	-	-	-
Critical Hdwy	6.49	6.2	4.12	-	-	-
Critical Hdwy Stg 1	5.49	-	-	-	-	-
Critical Hdwy Stg 2	5.49	-	-	-	-	-
Follow-up Hdwy	3.581	3.3	2.218	-	-	-
Pot Cap-1 Maneuver	329	597	1057	-	-	-
Stage 1	614	-	-	-	-	-
Stage 2	689	-	-	-	-	-
Platoon blocked, %				-	-	-
Mov Cap-1 Maneuver	329	597	1057	-	-	-
Mov Cap-2 Maneuver	329	-	-	-	-	-
Stage 1	613	-	-	-	-	-
Stage 2	689	-	-	-	-	-

Approach	EB	NB	SB
HCM Control Delay, s	16.3	0	0
HCM LOS	C		

Minor Lane/Major Mvmt	NBL	NBT	EBLn1	EBLn2	SBT	SBR
Capacity (veh/h)	1057	-	329	-	-	-
HCM Lane V/C Ratio	0.001	-	0.028	-	-	-
HCM Control Delay (s)	8.4	0	16.3	0	-	-
HCM Lane LOS	A	A	C	A	-	-
HCM 95th %tile Q(veh)	0	-	0.1	-	-	-

HCM Unsignalized Intersection Capacity Analysis
 108: E Illinois St & Deskins St

Existing Peak Hour AM
 Existing AM 2023



Movement	EBL	EBT	WBT	WBR	SBL	SBR
Lane Configurations		↗	↖		↘	↙
Traffic Volume (veh/h)	10	150	40	5	4	58
Future Volume (Veh/h)	10	150	40	5	4	58
Sign Control		Free	Free		Stop	
Grade		0%	0%		0%	
Peak Hour Factor	0.79	0.79	0.79	0.79	0.79	0.79
Hourly flow rate (vph)	13	190	51	6	5	73
Pedestrians		2	1		2	
Lane Width (ft)		12.0	12.0		12.0	
Walking Speed (ft/s)		3.5	3.5		3.5	
Percent Blockage		0	0		0	
Right turn flare (veh)						
Median type		None	None			
Median storage (veh)						
Upstream signal (ft)						
pX, platoon unblocked						
vC, conflicting volume	59				273	58
vC1, stage 1 conf vol						
vC2, stage 2 conf vol						
vCu, unblocked vol	59				273	58
tC, single (s)	4.1				6.6	6.2
tC, 2 stage (s)						
tF (s)	2.2				3.7	3.3
p0 queue free %	99				99	93
cM capacity (veh/h)	1555				662	1004
Direction, Lane #	EB 1	WB 1	SB 1			
Volume Total	203	57	78			
Volume Left	13	0	5			
Volume Right	0	6	73			
cSH	1555	1700	972			
Volume to Capacity	0.01	0.03	0.08			
Queue Length 95th (ft)	1	0	7			
Control Delay (s)	0.5	0.0	9.0			
Lane LOS	A		A			
Approach Delay (s)	0.5	0.0	9.0			
Approach LOS			A			
Intersection Summary						
Average Delay			2.4			
Intersection Capacity Utilization		26.4%		ICU Level of Service		A
Analysis Period (min)			15			

Intersection						
Int Delay, s/veh	2.4					
Movement	EBL	EBT	WBT	WBR	SBL	SBR
Lane Configurations		↕	↕		↕	
Traffic Vol, veh/h	10	150	40	5	4	58
Future Vol, veh/h	10	150	40	5	4	58
Conflicting Peds, #/hr	2	0	0	2	1	2
Sign Control	Free	Free	Free	Free	Stop	Stop
RT Channelized	-	None	-	None	-	None
Storage Length	-	-	-	-	0	-
Veh in Median Storage, #	-	0	0	-	0	-
Grade, %	-	0	0	-	0	-
Peak Hour Factor	79	79	79	79	79	79
Heavy Vehicles, %	0	3	2	0	25	2
Mvmt Flow	13	190	51	6	5	73

Major/Minor	Major1	Major2	Minor2		
Conflicting Flow All	59	0	-	0	273 58
Stage 1	-	-	-	-	56 -
Stage 2	-	-	-	-	217 -
Critical Hdwy	4.1	-	-	-	6.65 6.22
Critical Hdwy Stg 1	-	-	-	-	5.65 -
Critical Hdwy Stg 2	-	-	-	-	5.65 -
Follow-up Hdwy	2.2	-	-	-	3.725 3.318
Pot Cap-1 Maneuver	1558	-	-	-	670 1008
Stage 1	-	-	-	-	911 -
Stage 2	-	-	-	-	768 -
Platoon blocked, %		-	-	-	
Mov Cap-1 Maneuver	1555	-	-	-	661 1004
Mov Cap-2 Maneuver	-	-	-	-	661 -
Stage 1	-	-	-	-	901 -
Stage 2	-	-	-	-	766 -

Approach	EB	WB	SB
HCM Control Delay, s	0.5	0	9
HCM LOS			A

Minor Lane/Major Mvmt	EBL	EBT	WBT	WBR	SBLn1
Capacity (veh/h)	1555	-	-	-	971
HCM Lane V/C Ratio	0.008	-	-	-	0.081
HCM Control Delay (s)	7.3	0	-	-	9
HCM Lane LOS	A	A	-	-	A
HCM 95th %tile Q(veh)	0	-	-	-	0.3

HCM Unsignalized Intersection Capacity Analysis
 109: N College St (Hwy 219) & E Illinois St

Existing Peak Hour AM
 Existing AM 2023



Movement	EBL	EBR	NBL	NBT	SBT	SBR
Lane Configurations						
Traffic Volume (veh/h)	47	104	48	282	367	1
Future Volume (Veh/h)	47	104	48	282	367	1
Sign Control	Stop			Free	Free	
Grade	0%			0%	0%	
Peak Hour Factor	0.84	0.84	0.84	0.84	0.84	0.84
Hourly flow rate (vph)	56	124	57	336	437	1
Pedestrians	1				1	
Lane Width (ft)	12.0				12.0	
Walking Speed (ft/s)	3.5				3.5	
Percent Blockage	0				0	
Right turn flare (veh)						
Median type				None	None	
Median storage (veh)						
Upstream signal (ft)						
pX, platoon unblocked						
vC, conflicting volume	890	438	439			
vC1, stage 1 conf vol						
vC2, stage 2 conf vol						
vCu, unblocked vol	890	438	439			
tC, single (s)	6.5	6.2	4.1			
tC, 2 stage (s)						
tF (s)	3.6	3.3	2.2			
p0 queue free %	81	80	95			
cM capacity (veh/h)	289	611	1109			
Direction, Lane #	EB 1	NB 1	SB 1			
Volume Total	180	393	438			
Volume Left	56	57	0			
Volume Right	124	0	1			
cSH	454	1109	1700			
Volume to Capacity	0.40	0.05	0.26			
Queue Length 95th (ft)	47	4	0			
Control Delay (s)	18.1	1.7	0.0			
Lane LOS	C	A				
Approach Delay (s)	18.1	1.7	0.0			
Approach LOS	C					
Intersection Summary						
Average Delay			3.9			
Intersection Capacity Utilization			55.9%	ICU Level of Service	B	
Analysis Period (min)			15			

Intersection						
Int Delay, s/veh	3.7					
Movement	EBL	EBR	NBL	NBT	SBT	SBR
Lane Configurations	T			T		
Traffic Vol, veh/h	47	104	48	282	367	1
Future Vol, veh/h	47	104	48	282	367	1
Conflicting Peds, #/hr	1	0	1	0	0	1
Sign Control	Stop	Stop	Free	Free	Free	Free
RT Channelized	-	None	-	None	-	None
Storage Length	0	-	-	-	-	-
Veh in Median Storage, #	0	-	-	0	0	-
Grade, %	0	-	-	0	0	-
Peak Hour Factor	84	84	84	84	84	84
Heavy Vehicles, %	9	5	4	7	4	0
Mvmt Flow	56	124	57	336	437	1

Major/Minor	Minor2	Major1	Major2			
Conflicting Flow All	890	439	439	0	-	0
Stage 1	439	-	-	-	-	-
Stage 2	451	-	-	-	-	-
Critical Hdwy	6.49	6.25	4.14	-	-	-
Critical Hdwy Stg 1	5.49	-	-	-	-	-
Critical Hdwy Stg 2	5.49	-	-	-	-	-
Follow-up Hdwy	3.581	3.345	2.236	-	-	-
Pot Cap-1 Maneuver	305	612	1110	-	-	-
Stage 1	635	-	-	-	-	-
Stage 2	627	-	-	-	-	-
Platoon blocked, %				-	-	-
Mov Cap-1 Maneuver	285	611	1109	-	-	-
Mov Cap-2 Maneuver	285	-	-	-	-	-
Stage 1	594	-	-	-	-	-
Stage 2	626	-	-	-	-	-

Approach	EB	NB	SB
HCM Control Delay, s	18.2	1.2	0
HCM LOS	C		

Minor Lane/Major Mvmt	NBL	NBT	EBLn1	SBT	SBR
Capacity (veh/h)	1109	-	451	-	-
HCM Lane V/C Ratio	0.052	-	0.399	-	-
HCM Control Delay (s)	8.4	0	18.2	-	-
HCM Lane LOS	A	A	C	-	-
HCM 95th %tile Q(veh)	0.2	-	1.9	-	-

HCM Unsignalized Intersection Capacity Analysis
 110: N Main St (Hwy 240) & E North St

Existing Peak Hour AM
 Existing AM 2023



Movement	WBL	WBR	NBT	NBR	SBL	SBT
Lane Configurations						
Traffic Volume (veh/h)	1	2	353	4	4	467
Future Volume (Veh/h)	1	2	353	4	4	467
Sign Control	Stop		Free			Free
Grade	0%		0%			0%
Peak Hour Factor	0.92	0.92	0.92	0.92	0.92	0.92
Hourly flow rate (vph)	1	2	384	4	4	508
Pedestrians						4
Lane Width (ft)						12.0
Walking Speed (ft/s)						3.5
Percent Blockage						0
Right turn flare (veh)						
Median type			None			None
Median storage (veh)						
Upstream signal (ft)						
pX, platoon unblocked						
vC, conflicting volume	902	390			388	
vC1, stage 1 conf vol						
vC2, stage 2 conf vol						
vCu, unblocked vol	902	390			388	
tC, single (s)	7.4	6.2			4.1	
tC, 2 stage (s)						
tF (s)	4.4	3.3			2.2	
p0 queue free %	100	100			100	
cM capacity (veh/h)	211	660			1182	
Direction, Lane #	WB 1	NB 1	SB 1			
Volume Total	3	388	512			
Volume Left	1	0	4			
Volume Right	2	4	0			
cSH	386	1700	1182			
Volume to Capacity	0.01	0.23	0.00			
Queue Length 95th (ft)	1	0	0			
Control Delay (s)	14.4	0.0	0.1			
Lane LOS	B		A			
Approach Delay (s)	14.4	0.0	0.1			
Approach LOS	B					
Intersection Summary						
Average Delay			0.1			
Intersection Capacity Utilization			39.0%		ICU Level of Service	A
Analysis Period (min)			15			

Intersection						
Int Delay, s/veh	0.1					
Movement	WBL	WBR	NBT	NBR	SBL	SBT
Lane Configurations	W		T			T
Traffic Vol, veh/h	1	2	353	4	4	467
Future Vol, veh/h	1	2	353	4	4	467
Conflicting Peds, #/hr	0	4	0	0	0	0
Sign Control	Stop	Stop	Free	Free	Free	Free
RT Channelized	-	None	-	None	-	None
Storage Length	0	-	-	-	-	-
Veh in Median Storage, #	0	-	0	-	-	0
Grade, %	0	-	0	-	-	0
Peak Hour Factor	92	92	92	92	92	92
Heavy Vehicles, %	100	0	6	0	0	6
Mvmt Flow	1	2	384	4	4	508

















Major/Minor	Minor1	Major1	Major2		
Conflicting Flow All	902	390	0	0	388
Stage 1	386	-	-	-	-
Stage 2	516	-	-	-	-
Critical Hdwy	7.4	6.2	-	-	4.1
Critical Hdwy Stg 1	6.4	-	-	-	-
Critical Hdwy Stg 2	6.4	-	-	-	-
Follow-up Hdwy	4.4	3.3	-	-	2.2
Pot Cap-1 Maneuver	211	663	-	-	1182
Stage 1	517	-	-	-	-
Stage 2	441	-	-	-	-
Platoon blocked, %			-	-	-
Mov Cap-1 Maneuver	210	660	-	-	1182
Mov Cap-2 Maneuver	210	-	-	-	-
Stage 1	517	-	-	-	-
Stage 2	439	-	-	-	-

Approach	WB	NB	SB
HCM Control Delay, s	14.4	0	0.1
HCM LOS	B		

Minor Lane/Major Mvmt	NBT	NBRWBLn1	SBL	SBT
Capacity (veh/h)	-	-	385	1182
HCM Lane V/C Ratio	-	-	0.008	0.004
HCM Control Delay (s)	-	-	14.4	8.1
HCM Lane LOS	-	-	B	A
HCM 95th %tile Q(veh)	-	-	0	0

HCM Unsignalized Intersection Capacity Analysis
101: N Main St & E Columbia Dr

Existing Peak Hour PM
Existing PM 2023

												
Movement	EBL	EBT	EBR	WBL	WBT	WBR	NBL	NBT	NBR	SBL	SBT	SBR
Lane Configurations												
Sign Control		Stop			Stop			Stop			Stop	
Traffic Volume (vph)	1	9	9	8	9	12	7	98	12	8	56	3
Future Volume (vph)	1	9	9	8	9	12	7	98	12	8	56	3
Peak Hour Factor	0.83	0.83	0.83	0.83	0.83	0.83	0.83	0.83	0.83	0.83	0.83	0.83
Hourly flow rate (vph)	1	11	11	10	11	14	8	118	14	10	67	4
Direction, Lane #	EB 1	WB 1	NB 1	SB 1								
Volume Total (vph)	23	35	140	81								
Volume Left (vph)	1	10	8	10								
Volume Right (vph)	11	14	14	4								
Hadj (s)	-0.19	-0.07	-0.03	0.05								
Departure Headway (s)	4.2	4.3	4.1	4.2								
Degree Utilization, x	0.03	0.04	0.16	0.09								
Capacity (veh/h)	803	776	859	834								
Control Delay (s)	7.3	7.5	7.8	7.7								
Approach Delay (s)	7.3	7.5	7.8	7.7								
Approach LOS	A	A	A	A								
Intersection Summary												
Delay			7.7									
Level of Service			A									
Intersection Capacity Utilization			19.6%	ICU Level of Service	A							
Analysis Period (min)			15									

Intersection	
Intersection Delay, s/veh	7.7
Intersection LOS	A

















Movement	EBL	EBT	EBR	WBL	WBT	WBR	NBL	NBT	NBR	SBL	SBT	SBR
Lane Configurations		↕			↕			↕			↕	
Traffic Vol, veh/h	1	9	9	8	9	12	7	98	12	8	56	3
Future Vol, veh/h	1	9	9	8	9	12	7	98	12	8	56	3
Peak Hour Factor	0.83	0.83	0.83	0.83	0.83	0.83	0.83	0.83	0.83	0.83	0.83	0.83
Heavy Vehicles, %	0	0	11	12	0	8	0	1	0	12	2	0
Mvmt Flow	1	11	11	10	11	14	8	118	14	10	67	4
Number of Lanes	0	1	0	0	1	0	0	1	0	0	1	0

Approach	EB	WB	NB	SB
Opposing Approach	WB	EB	SB	NB
Opposing Lanes	1	1	1	1
Conflicting Approach Left	SB	NB	EB	WB
Conflicting Lanes Left	1	1	1	1
Conflicting Approach Right	NB	SB	WB	EB
Conflicting Lanes Right	1	1	1	1
HCM Control Delay	7.3	7.6	7.8	7.8
HCM LOS	A	A	A	A

Lane	NBLn1	EBLn1	WBLn1	SBLn1
Vol Left, %	6%	5%	28%	12%
Vol Thru, %	84%	47%	31%	84%
Vol Right, %	10%	47%	41%	4%
Sign Control	Stop	Stop	Stop	Stop
Traffic Vol by Lane	117	19	29	67
LT Vol	7	1	8	8
Through Vol	98	9	9	56
RT Vol	12	9	12	3
Lane Flow Rate	141	23	35	81
Geometry Grp	1	1	1	1
Degree of Util (X)	0.157	0.026	0.043	0.097
Departure Headway (Hd)	4.011	4.153	4.423	4.308
Convergence, Y/N	Yes	Yes	Yes	Yes
Cap	887	867	814	825
Service Time	2.069	2.154	2.423	2.372
HCM Lane V/C Ratio	0.159	0.027	0.043	0.098
HCM Control Delay	7.8	7.3	7.6	7.8
HCM Lane LOS	A	A	A	A
HCM 95th-tile Q	0.6	0.1	0.1	0.3

HCM Unsignalized Intersection Capacity Analysis
 102: N Main St & W Pinehurst Ct/E Pinehurst Dr

Existing Peak Hour PM
 Existing PM 2023

												
Movement	EBL	EBT	EBR	WBL	WBT	WBR	NBL	NBT	NBR	SBL	SBT	SBR
Lane Configurations												
Traffic Volume (veh/h)	0	5	3	16	1	10	3	108	14	3	71	2
Future Volume (Veh/h)	0	5	3	16	1	10	3	108	14	3	71	2
Sign Control		Stop			Stop			Free			Free	
Grade		0%			0%			0%			0%	
Peak Hour Factor	0.82	0.82	0.82	0.82	0.82	0.82	0.82	0.82	0.82	0.82	0.82	0.82
Hourly flow rate (vph)	0	6	4	20	1	12	4	132	17	4	87	2
Pedestrians												
Lane Width (ft)												
Walking Speed (ft/s)												
Percent Blockage												
Right turn flare (veh)												
Median type												
								None			None	
Median storage (veh)												
Upstream signal (ft)												
pX, platoon unblocked												
vC, conflicting volume	257	253	88	252	246	140	89				149	
vC1, stage 1 conf vol												
vC2, stage 2 conf vol												
vCu, unblocked vol	257	253	88	252	246	140	89				149	
tC, single (s)	7.1	6.7	6.5	7.2	6.5	6.2	4.4				4.1	
tC, 2 stage (s)												
tF (s)	3.5	4.2	3.6	3.6	4.0	3.3	2.5				2.2	
p0 queue free %	100	99	100	97	100	99	100				100	
cM capacity (veh/h)	687	617	891	682	656	913	1332				1445	
Direction, Lane #												
	EB 1	WB 1	NB 1	SB 1								
Volume Total	10	33	153	93								
Volume Left	0	20	4	4								
Volume Right	4	12	17	2								
cSH	704	750	1332	1445								
Volume to Capacity	0.01	0.04	0.00	0.00								
Queue Length 95th (ft)	1	3	0	0								
Control Delay (s)	10.2	10.0	0.2	0.3								
Lane LOS	B	B	A	A								
Approach Delay (s)	10.2	10.0	0.2	0.3								
Approach LOS	B	B										
Intersection Summary												
Average Delay			1.7									
Intersection Capacity Utilization			22.6%	ICU Level of Service							A	
Analysis Period (min)			15									

Intersection												
Int Delay, s/veh	1.7											
Movement	EBL	EBT	EBR	WBL	WBT	WBR	NBL	NBT	NBR	SBL	SBT	SBR
Lane Configurations		↕			↕			↕			↕	
Traffic Vol, veh/h	0	5	3	16	1	10	3	108	14	3	71	2
Future Vol, veh/h	0	5	3	16	1	10	3	108	14	3	71	2
Conflicting Peds, #/hr	0	0	0	0	0	0	0	0	0	0	0	0
Sign Control	Stop	Stop	Stop	Stop	Stop	Stop	Free	Free	Free	Free	Free	Free
RT Channelized	-	-	None	-	-	None	-	-	None	-	-	None
Storage Length	-	-	-	-	-	-	-	-	-	-	-	-
Veh in Median Storage, #	-	0	-	-	0	-	-	0	-	-	0	-
Grade, %	-	0	-	-	0	-	-	0	-	-	0	-
Peak Hour Factor	82	82	82	82	82	82	82	82	82	82	82	82
Heavy Vehicles, %	0	20	33	6	0	0	33	1	0	0	4	0
Mvmt Flow	0	6	4	20	1	12	4	132	17	4	87	2

















Major/Minor	Minor2		Minor1		Major1			Major2				
Conflicting Flow All	251	253	88	250	246	141	89	0	0	149	0	0
Stage 1	96	96	-	149	149	-	-	-	-	-	-	-
Stage 2	155	157	-	101	97	-	-	-	-	-	-	-
Critical Hdwy	7.1	6.7	6.53	7.16	6.5	6.2	4.43	-	-	4.1	-	-
Critical Hdwy Stg 1	6.1	5.7	-	6.16	5.5	-	-	-	-	-	-	-
Critical Hdwy Stg 2	6.1	5.7	-	6.16	5.5	-	-	-	-	-	-	-
Follow-up Hdwy	3.5	4.18	3.597	3.554	4	3.3	2.497	-	-	2.2	-	-
Pot Cap-1 Maneuver	707	621	891	695	660	912	1332	-	-	1445	-	-
Stage 1	916	782	-	844	778	-	-	-	-	-	-	-
Stage 2	852	735	-	895	819	-	-	-	-	-	-	-
Platoon blocked, %								-	-	-	-	-
Mov Cap-1 Maneuver	694	617	891	684	656	912	1332	-	-	1445	-	-
Mov Cap-2 Maneuver	694	617	-	684	656	-	-	-	-	-	-	-
Stage 1	913	780	-	841	776	-	-	-	-	-	-	-
Stage 2	837	733	-	882	817	-	-	-	-	-	-	-

Approach	EB		WB		NB		SB	
HCM Control Delay, s	10.2		10		0.2		0.3	
HCM LOS	B		B					

Minor Lane/Major Mvmt	NBL	NBT	NBR	EBLn1WBLn1	SBL	SBT	SBR
Capacity (veh/h)	1332	-	-	697	752	1445	-
HCM Lane V/C Ratio	0.003	-	-	0.014	0.044	0.003	-
HCM Control Delay (s)	7.7	0	-	10.2	10	7.5	0
HCM Lane LOS	A	A	-	B	B	A	A
HCM 95th %tile Q(veh)	0	-	-	0	0.1	0	-

HCM Unsignalized Intersection Capacity Analysis
 103: N College St (Hwy 219) & E Pinehurst Dr

Existing Peak Hour PM
 Existing PM 2023

												
Movement	EBL	EBT	EBR	WBL	WBT	WBR	NBL	NBT	NBR	SBL	SBT	SBR
Lane Configurations												
Traffic Volume (veh/h)	0	0	0	0	0	0	0	0	0	0	0	0
Future Volume (Veh/h)	0	0	0	0	0	0	0	0	0	0	0	0
Sign Control		Stop			Stop			Free			Free	
Grade		0%			0%			0%			0%	
Peak Hour Factor	0.92	0.92	0.92	0.92	0.92	0.92	0.92	0.92	0.92	0.92	0.92	0.92
Hourly flow rate (vph)	0	0	0	0	0	0	0	0	0	0	0	0
Pedestrians												
Lane Width (ft)												
Walking Speed (ft/s)												
Percent Blockage												
Right turn flare (veh)												
Median type								None			None	
Median storage (veh)												
Upstream signal (ft)												
pX, platoon unblocked												
vC, conflicting volume	0	0	0	0	0	0	0			0		
vC1, stage 1 conf vol												
vC2, stage 2 conf vol												
vCu, unblocked vol	0	0	0	0	0	0	0			0		
tC, single (s)	7.1	6.5	6.2	7.1	6.5	6.2	4.1			4.1		
tC, 2 stage (s)												
tF (s)	3.5	4.0	3.3	3.5	4.0	3.3	2.2			2.2		
p0 queue free %	100	100	100	100	100	100	100			100		
cM capacity (veh/h)	1023	896	1085	1023	896	1085	1623			1623		
Direction, Lane #	EB 1	WB 1	NB 1	SB 1								
Volume Total	0	0	0	0								
Volume Left	0	0	0	0								
Volume Right	0	0	0	0								
cSH	1700	1700	1700	1700								
Volume to Capacity	0.07	0.03	0.00	0.00								
Queue Length 95th (ft)	0	0	0	0								
Control Delay (s)	0.0	0.0	0.0	0.0								
Lane LOS	A	A										
Approach Delay (s)	0.0	0.0	0.0	0.0								
Approach LOS	A	A										
Intersection Summary												
Average Delay			0.0									
Intersection Capacity Utilization			0.0%		ICU Level of Service					A		
Analysis Period (min)			15									

Intersection												
Int Delay, s/veh	0											
Movement	EBL	EBT	EBR	WBL	WBT	WBR	NBL	NBT	NBR	SBL	SBT	SBR
Lane Configurations		↕			↕			↕			↕	
Traffic Vol, veh/h	0	0	0	0	0	0	0	0	0	0	0	0
Future Vol, veh/h	0	0	0	0	0	0	0	0	0	0	0	0
Conflicting Peds, #/hr	0	0	0	0	0	0	0	0	0	0	0	0
Sign Control	Stop	Stop	Stop	Stop	Stop	Stop	Free	Free	Free	Free	Free	Free
RT Channelized	-	-	None	-	-	None	-	-	None	-	-	None
Storage Length	-	-	-	-	-	-	-	-	-	-	-	-
Veh in Median Storage, #	-	0	-	-	0	-	-	0	-	-	0	-
Grade, %	-	0	-	-	0	-	-	0	-	-	0	-
Peak Hour Factor	92	92	92	92	92	92	92	92	92	92	92	92
Heavy Vehicles, %	2	2	2	2	2	2	2	2	2	2	2	2
Mvmt Flow	0	0	0	0	0	0	0	0	0	0	0	0

Major/Minor	Minor2		Minor1		Major1		Major2					
Conflicting Flow All	1	1	1	1	1	0	1	0	0	0	0	0
Stage 1	1	1	-	0	0	-	-	-	-	-	-	-
Stage 2	0	0	-	1	1	-	-	-	-	-	-	-
Critical Hdwy	7.12	6.52	6.22	7.12	6.52	6.22	4.12	-	-	4.12	-	-
Critical Hdwy Stg 1	6.12	5.52	-	6.12	5.52	-	-	-	-	-	-	-
Critical Hdwy Stg 2	6.12	5.52	-	6.12	5.52	-	-	-	-	-	-	-
Follow-up Hdwy	3.518	4.018	3.318	3.518	4.018	3.318	2.218	-	-	2.218	-	-
Pot Cap-1 Maneuver	1022	895	1084	1022	895	-	1622	-	-	-	-	-
Stage 1	1022	895	-	-	-	-	-	-	-	-	-	-
Stage 2	-	-	-	1022	895	-	-	-	-	-	-	-
Platoon blocked, %	-	-	-	-	-	-	-	-	-	-	-	-
Mov Cap-1 Maneuver	-	895	1084	1022	895	-	1622	-	-	-	-	-
Mov Cap-2 Maneuver	-	895	-	1022	895	-	-	-	-	-	-	-
Stage 1	1022	895	-	-	-	-	-	-	-	-	-	-
Stage 2	-	-	-	1022	895	-	-	-	-	-	-	-

Approach	EB		WB		NB		SB	
HCM Control Delay, s	0		0		0		0	
HCM LOS	A		A					

Minor Lane/Major Mvmt	NBL	NBT	NBR	EBLn1	WB Ln1	SBL	SBT	SBR
Capacity (veh/h)	1622	-	-	-	-	-	-	-
HCM Lane V/C Ratio	-	-	-	-	-	-	-	-
HCM Control Delay (s)	0	-	-	0	0	0	-	-
HCM Lane LOS	A	-	-	A	A	A	-	-
HCM 95th %tile Q(veh)	0	-	-	-	-	-	-	-

Intersection						
Int Delay, s/veh	8.2					
Movement	SEL	SET	NWT	NWR	SWL	SWR
Lane Configurations						
Traffic Vol, veh/h	72	332	558	158	95	86
Future Vol, veh/h	72	332	558	158	95	86
Conflicting Peds, #/hr	0	0	0	0	0	0
Sign Control	Free	Free	Free	Free	Stop	Stop
RT Channelized	-	None	-	None	-	None
Storage Length	75	-	-	-	0	-
Veh in Median Storage, #	-	0	0	-	0	-
Grade, %	-	0	0	-	0	-
Peak Hour Factor	92	92	92	92	92	92
Heavy Vehicles, %	1	5	3	1	2	1
Mvmt Flow	78	361	607	172	103	93

Major/Minor	Major1	Major2	Minor2		
Conflicting Flow All	779	0	-	0	1210 693
Stage 1	-	-	-	-	693 -
Stage 2	-	-	-	-	517 -
Critical Hdwy	4.11	-	-	-	6.42 6.21
Critical Hdwy Stg 1	-	-	-	-	5.42 -
Critical Hdwy Stg 2	-	-	-	-	5.42 -
Follow-up Hdwy	2.209	-	-	-	3.518 3.309
Pot Cap-1 Maneuver	842	-	-	-	202 445
Stage 1	-	-	-	-	496 -
Stage 2	-	-	-	-	598 -
Platoon blocked, %		-	-	-	
Mov Cap-1 Maneuver	842	-	-	-	183 445
Mov Cap-2 Maneuver	-	-	-	-	183 -
Stage 1	-	-	-	-	450 -
Stage 2	-	-	-	-	598 -

Approach	SE	NW	SW
HCM Control Delay, s	1.7	0	55.1
HCM LOS			F

Minor Lane/Major Mvmt	NWT	NWR	SEL	SETSWLn1
Capacity (veh/h)	-	-	842	- 254
HCM Lane V/C Ratio	-	-	0.093	- 0.775
HCM Control Delay (s)	-	-	9.7	- 55.1
HCM Lane LOS	-	-	A	- F
HCM 95th %tile Q(veh)	-	-	0.3	- 5.7

HCM Unsignalized Intersection Capacity Analysis
105: E Illinois St & N Main St

Existing Peak Hour PM
Existing PM 2023



Movement	EBL	EBR	NBL	NBT	SBT	SBR
Lane Configurations						
Traffic Volume (veh/h)	142	88	112	22	20	66
Future Volume (Veh/h)	142	88	112	22	20	66
Sign Control	Free			Stop	Stop	
Grade	0%			0%	0%	
Peak Hour Factor	0.87	0.87	0.87	0.87	0.87	0.87
Hourly flow rate (vph)	163	101	129	25	23	76
Pedestrians	1			1	1	
Lane Width (ft)	12.0			12.0	12.0	
Walking Speed (ft/s)	3.5			3.5	3.5	
Percent Blockage	0			0	0	
Right turn flare (veh)						
Median type	None					
Median storage (veh)						
Upstream signal (ft)						
pX, platoon unblocked						
vC, conflicting volume	1		466	378	429	2
vC1, stage 1 conf vol						
vC2, stage 2 conf vol						
vCu, unblocked vol	1		466	378	429	2
tC, single (s)	4.1		7.1	6.5	6.5	6.2
tC, 2 stage (s)						
tF (s)	2.2		3.5	4.0	4.0	3.3
p0 queue free %	90		69	95	95	93
cM capacity (veh/h)	1627		417	500	462	1071
Direction, Lane #	EB 1	NB 1	SB 1			
Volume Total	264	154	99			
Volume Left	163	129	0			
Volume Right	101	0	76			
cSH	1627	429	820			
Volume to Capacity	0.10	0.36	0.12			
Queue Length 95th (ft)	8	40	10			
Control Delay (s)	4.9	18.0	10.0			
Lane LOS	A	C	A			
Approach Delay (s)	4.9	18.0	10.0			
Approach LOS		C	A			
Intersection Summary						
Average Delay			9.8			
Intersection Capacity Utilization			34.0%	ICU Level of Service	A	
Analysis Period (min)			15			

HCM Unsignalized Intersection Capacity Analysis
106: N Washington St & E Illinois St

Existing Peak Hour PM
Existing PM 2023

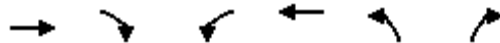

Movement	EBT	EBR	WBL	WBT	NBL	NBR
Lane Configurations	→			←	←	←
Traffic Volume (veh/h)	100	10	32	131	10	14
Future Volume (Veh/h)	100	10	32	131	10	14
Sign Control	Free			Free	Stop	
Grade	0%			0%	0%	
Peak Hour Factor	0.84	0.84	0.84	0.84	0.84	0.84
Hourly flow rate (vph)	119	12	38	156	12	17
Pedestrians						
Lane Width (ft)						
Walking Speed (ft/s)						
Percent Blockage						
Right turn flare (veh)						
Median type	None			None		
Median storage (veh)						
Upstream signal (ft)						
pX, platoon unblocked						
vC, conflicting volume			131			125
vC1, stage 1 conf vol						
vC2, stage 2 conf vol						
vCu, unblocked vol			131			125
tC, single (s)			4.1			6.2
tC, 2 stage (s)						
tF (s)			2.2			3.3
p0 queue free %			97			98
cM capacity (veh/h)			1448			931
Direction, Lane #	EB 1	WB 1	NB 1			
Volume Total	131	194	29			
Volume Left	0	38	12			
Volume Right	12	0	17			
cSH	1700	1448	776			
Volume to Capacity	0.08	0.03	0.04			
Queue Length 95th (ft)	0	2	3			
Control Delay (s)	0.0	1.7	9.8			
Lane LOS			A			
Approach Delay (s)	0.0	1.7	9.8			
Approach LOS			A			
Intersection Summary						
Average Delay			1.7			
Intersection Capacity Utilization			25.3%	ICU Level of Service		A
Analysis Period (min)			15			

Intersection						
Int Delay, s/veh	1.6					
Movement	EBT	EBR	WBL	WBT	NBL	NBR
Lane Configurations						
Traffic Vol, veh/h	100	10	32	131	10	14
Future Vol, veh/h	100	10	32	131	10	14
Conflicting Peds, #/hr	0	0	0	0	0	0
Sign Control	Free	Free	Free	Free	Stop	Stop
RT Channelized	-	None	-	None	-	None
Storage Length	-	-	-	-	0	-
Veh in Median Storage, #	0	-	-	0	0	-
Grade, %	0	-	-	0	0	-
Peak Hour Factor	84	84	84	84	84	84
Heavy Vehicles, %	4	10	3	2	0	0
Mvmt Flow	119	12	38	156	12	17

Major/Minor	Major1	Major2	Minor1		
Conflicting Flow All	0	0	131	0	357
Stage 1	-	-	-	-	125
Stage 2	-	-	-	-	232
Critical Hdwy	-	-	4.13	-	6.4
Critical Hdwy Stg 1	-	-	-	-	5.4
Critical Hdwy Stg 2	-	-	-	-	5.4
Follow-up Hdwy	-	-	2.227	-	3.5
Pot Cap-1 Maneuver	-	-	1448	-	645
Stage 1	-	-	-	-	906
Stage 2	-	-	-	-	811
Platoon blocked, %	-	-	-	-	-
Mov Cap-1 Maneuver	-	-	1448	-	626
Mov Cap-2 Maneuver	-	-	-	-	626
Stage 1	-	-	-	-	906
Stage 2	-	-	-	-	787

Approach	EB	WB	NB
HCM Control Delay, s	0	1.5	9.8
HCM LOS			A

Minor Lane/Major Mvmt	NBLn1	EBT	EBR	WBL	WBT
Capacity (veh/h)	774	-	-	1448	-
HCM Lane V/C Ratio	0.037	-	-	0.026	-
HCM Control Delay (s)	9.8	-	-	7.6	0
HCM Lane LOS	A	-	-	A	A
HCM 95th %tile Q(veh)	0.1	-	-	0.1	-

Intersection						
Int Delay, s/veh	0.3					
Movement	EBL	EBR	NBL	NBT	SBT	SBR
Lane Configurations						
Traffic Vol, veh/h	15	0	0	365	505	84
Future Vol, veh/h	15	0	0	365	505	84
Conflicting Peds, #/hr	0	0	0	0	0	0
Sign Control	Stop	Stop	Free	Free	Free	Free
RT Channelized	-	Stop	-	None	-	None
Storage Length	0	50	-	-	-	-
Veh in Median Storage, #	0	-	-	0	0	-
Grade, %	0	-	-	0	0	-
Peak Hour Factor	90	90	90	90	90	90
Heavy Vehicles, %	7	0	0	4	4	5
Mvmt Flow	17	0	0	406	561	93

Major/Minor	Minor2	Major1	Major2			
Conflicting Flow All	1014	608	654	0	-	0
Stage 1	608	-	-	-	-	-
Stage 2	406	-	-	-	-	-
Critical Hdwy	6.47	6.2	4.1	-	-	-
Critical Hdwy Stg 1	5.47	-	-	-	-	-
Critical Hdwy Stg 2	5.47	-	-	-	-	-
Follow-up Hdwy	3.563	3.3	2.2	-	-	-
Pot Cap-1 Maneuver	259	499	943	-	-	-
Stage 1	534	-	-	-	-	-
Stage 2	662	-	-	-	-	-
Platoon blocked, %				-	-	-
Mov Cap-1 Maneuver	259	499	943	-	-	-
Mov Cap-2 Maneuver	259	-	-	-	-	-
Stage 1	534	-	-	-	-	-
Stage 2	662	-	-	-	-	-

Approach	EB	NB	SB
HCM Control Delay, s	19.9	0	0
HCM LOS	C		

Minor Lane/Major Mvmt	NBL	NBT	EBLn1	EBLn2	SBT	SBR
Capacity (veh/h)	943	-	259	-	-	-
HCM Lane V/C Ratio	-	-	0.064	-	-	-
HCM Control Delay (s)	0	-	19.9	0	-	-
HCM Lane LOS	A	-	C	A	-	-
HCM 95th %tile Q(veh)	0	-	0.2	-	-	-

HCM Unsignalized Intersection Capacity Analysis
 108: E Illinois St & Deskins St

Existing Peak Hour PM
 Existing PM 2023



Movement	EBL	EBT	WBT	WBR	SBL	SBR
Lane Configurations		↔	↔		↔	
Traffic Volume (veh/h)	15	118	77	9	5	76
Future Volume (Veh/h)	15	118	77	9	5	76
Sign Control		Free	Free		Stop	
Grade		0%	0%		0%	
Peak Hour Factor	0.84	0.84	0.84	0.84	0.84	0.84
Hourly flow rate (vph)	18	140	92	11	6	90
Pedestrians		2			3	
Lane Width (ft)		12.0			12.0	
Walking Speed (ft/s)		3.5			3.5	
Percent Blockage		0			0	
Right turn flare (veh)						
Median type		None	None			
Median storage (veh)						
Upstream signal (ft)						
pX, platoon unblocked						
vC, conflicting volume	106				276	102
vC1, stage 1 conf vol						
vC2, stage 2 conf vol						
vCu, unblocked vol	106				276	102
tC, single (s)	4.1				6.4	6.2
tC, 2 stage (s)						
tF (s)	2.2				3.5	3.3
p0 queue free %	99				99	91
cM capacity (veh/h)	1493				707	951
Direction, Lane #	EB 1	WB 1	SB 1			
Volume Total	158	103	96			
Volume Left	18	0	6			
Volume Right	0	11	90			
cSH	1493	1700	931			
Volume to Capacity	0.01	0.06	0.10			
Queue Length 95th (ft)	1	0	9			
Control Delay (s)	0.9	0.0	9.3			
Lane LOS	A		A			
Approach Delay (s)	0.9	0.0	9.3			
Approach LOS			A			
Intersection Summary						
Average Delay			2.9			
Intersection Capacity Utilization			26.1%	ICU Level of Service		A
Analysis Period (min)			15			

Intersection						
Int Delay, s/veh	2.9					
Movement	EBL	EBT	WBT	WBR	SBL	SBR
Lane Configurations		↶	↷		↶	
Traffic Vol, veh/h	15	118	77	9	5	76
Future Vol, veh/h	15	118	77	9	5	76
Conflicting Peds, #/hr	3	0	0	3	0	2
Sign Control	Free	Free	Free	Free	Stop	Stop
RT Channelized	-	None	-	None	-	None
Storage Length	-	-	-	-	0	-
Veh in Median Storage, #	-	0	0	-	0	-
Grade, %	-	0	0	-	0	-
Peak Hour Factor	84	84	84	84	84	84
Heavy Vehicles, %	0	1	1	0	0	1
Mvmt Flow	18	140	92	11	6	90

Major/Minor	Major1	Major2	Minor2		
Conflicting Flow All	106	0	-	0	277 103
Stage 1	-	-	-	-	101 -
Stage 2	-	-	-	-	176 -
Critical Hdwy	4.1	-	-	-	6.4 6.21
Critical Hdwy Stg 1	-	-	-	-	5.4 -
Critical Hdwy Stg 2	-	-	-	-	5.4 -
Follow-up Hdwy	2.2	-	-	-	3.5 3.309
Pot Cap-1 Maneuver	1498	-	-	-	717 955
Stage 1	-	-	-	-	928 -
Stage 2	-	-	-	-	859 -
Platoon blocked, %		-	-	-	
Mov Cap-1 Maneuver	1494	-	-	-	703 950
Mov Cap-2 Maneuver	-	-	-	-	703 -
Stage 1	-	-	-	-	913 -
Stage 2	-	-	-	-	856 -

Approach	EB	WB	SB
HCM Control Delay, s	0.8	0	9.3
HCM LOS			A

Minor Lane/Major Mvmt	EBL	EBT	WBT	WBR	SBLn1
Capacity (veh/h)	1494	-	-	-	930
HCM Lane V/C Ratio	0.012	-	-	-	0.104
HCM Control Delay (s)	7.4	0	-	-	9.3
HCM Lane LOS	A	A	-	-	A
HCM 95th %tile Q(veh)	0	-	-	-	0.3

HCM Unsignalized Intersection Capacity Analysis
 109: N College St (Hwy 219) & E Illinois St

Existing Peak Hour PM
 Existing PM 2023



Movement	EBL	EBR	NBL	NBT	SBT	SBR
Lane Configurations						
Traffic Volume (veh/h)	33	72	75	330	494	7
Future Volume (Veh/h)	33	72	75	330	494	7
Sign Control	Stop			Free	Free	
Grade	0%			0%	0%	
Peak Hour Factor	0.92	0.92	0.92	0.92	0.92	0.92
Hourly flow rate (vph)	36	78	82	359	537	8
Pedestrians						
Lane Width (ft)						
Walking Speed (ft/s)						
Percent Blockage						
Right turn flare (veh)						
Median type				None	None	
Median storage (veh)						
Upstream signal (ft)						
pX, platoon unblocked						
vC, conflicting volume	1064	541	545			
vC1, stage 1 conf vol						
vC2, stage 2 conf vol						
vCu, unblocked vol	1064	541	545			
tC, single (s)	6.4	6.3	4.1			
tC, 2 stage (s)						
tF (s)	3.5	3.4	2.2			
p0 queue free %	84	85	92			
cM capacity (veh/h)	226	533	1029			
Direction, Lane #	EB 1	NB 1	SB 1			
Volume Total	114	441	545			
Volume Left	36	82	0			
Volume Right	78	0	8			
cSH	373	1029	1700			
Volume to Capacity	0.31	0.08	0.32			
Queue Length 95th (ft)	32	6	0			
Control Delay (s)	18.8	2.4	0.0			
Lane LOS	C	A				
Approach Delay (s)	18.8	2.4	0.0			
Approach LOS	C					
Intersection Summary						
Average Delay			2.9			
Intersection Capacity Utilization			64.2%	ICU Level of Service	C	
Analysis Period (min)			15			

Intersection						
Int Delay, s/veh	2.6					
Movement	EBL	EBR	NBL	NBT	SBT	SBR
Lane Configurations	T			T		
Traffic Vol, veh/h	33	72	75	330	494	7
Future Vol, veh/h	33	72	75	330	494	7
Conflicting Peds, #/hr	0	0	0	0	0	0
Sign Control	Stop	Stop	Free	Free	Free	Free
RT Channelized	-	None	-	None	-	None
Storage Length	0	-	-	-	-	-
Veh in Median Storage, #	0	-	-	0	0	-
Grade, %	0	-	-	0	0	-
Peak Hour Factor	92	92	92	92	92	92
Heavy Vehicles, %	3	6	1	4	4	0
Mvmt Flow	36	78	82	359	537	8

Major/Minor	Minor2	Major1	Major2			
Conflicting Flow All	1064	541	545	0	-	0
Stage 1	541	-	-	-	-	-
Stage 2	523	-	-	-	-	-
Critical Hdwy	6.43	6.26	4.11	-	-	-
Critical Hdwy Stg 1	5.43	-	-	-	-	-
Critical Hdwy Stg 2	5.43	-	-	-	-	-
Follow-up Hdwy	3.527	3.354	2.209	-	-	-
Pot Cap-1 Maneuver	246	533	1029	-	-	-
Stage 1	581	-	-	-	-	-
Stage 2	593	-	-	-	-	-
Platoon blocked, %				-	-	-
Mov Cap-1 Maneuver	221	533	1029	-	-	-
Mov Cap-2 Maneuver	221	-	-	-	-	-
Stage 1	523	-	-	-	-	-
Stage 2	593	-	-	-	-	-

Approach	EB	NB	SB
HCM Control Delay, s	19.1	1.6	0
HCM LOS	C		

Minor Lane/Major Mvmt	NBL	NBT	EBLn1	SBT	SBR
Capacity (veh/h)	1029	-	369	-	-
HCM Lane V/C Ratio	0.079	-	0.309	-	-
HCM Control Delay (s)	8.8	0	19.1	-	-
HCM Lane LOS	A	A	C	-	-
HCM 95th %tile Q(veh)	0.3	-	1.3	-	-

HCM Unsignalized Intersection Capacity Analysis
 110: N Main St (Hwy 240) & E North St

Existing Peak Hour PM
 Existing PM 2023



Movement	WBL	WBR	NBT	NBR	SBL	SBT
Lane Configurations						
Traffic Volume (veh/h)	5	8	703	5	3	422
Future Volume (Veh/h)	5	8	703	5	3	422
Sign Control	Stop		Free		Free	
Grade	0%		0%		0%	
Peak Hour Factor	0.93	0.93	0.93	0.93	0.93	0.93
Hourly flow rate (vph)	5	9	756	5	3	454
Pedestrians						
Lane Width (ft)						
Walking Speed (ft/s)						
Percent Blockage						
Right turn flare (veh)						
Median type			None		None	
Median storage (veh)						
Upstream signal (ft)						
pX, platoon unblocked						
vC, conflicting volume	1218	758			761	
vC1, stage 1 conf vol						
vC2, stage 2 conf vol						
vCu, unblocked vol	1218	758			761	
tC, single (s)	6.4	6.5			4.1	
tC, 2 stage (s)						
tF (s)	3.5	3.5			2.2	
p0 queue free %	98	98			100	
cM capacity (veh/h)	200	372			860	
Direction, Lane #	WB 1	NB 1	SB 1			
Volume Total	14	761	457			
Volume Left	5	0	3			
Volume Right	9	5	0			
cSH	285	1700	860			
Volume to Capacity	0.05	0.45	0.00			
Queue Length 95th (ft)	4	0	0			
Control Delay (s)	18.3	0.0	0.1			
Lane LOS	C		A			
Approach Delay (s)	18.3	0.0	0.1			
Approach LOS	C					
Intersection Summary						
Average Delay			0.2			
Intersection Capacity Utilization			47.3%	ICU Level of Service		A
Analysis Period (min)			15			

Intersection						
Int Delay, s/veh	0.2					
Movement	WBL	WBR	NBT	NBR	SBL	SBT
Lane Configurations						
Traffic Vol, veh/h	5	8	703	5	3	422
Future Vol, veh/h	5	8	703	5	3	422
Conflicting Peds, #/hr	0	0	0	0	0	0
Sign Control	Stop	Stop	Free	Free	Free	Free
RT Channelized	-	None	-	None	-	None
Storage Length	0	-	-	-	-	-
Veh in Median Storage, #	0	-	0	-	-	0
Grade, %	0	-	0	-	-	0
Peak Hour Factor	93	93	93	93	93	93
Heavy Vehicles, %	0	25	2	0	0	4
Mvmt Flow	5	9	756	5	3	454

















Major/Minor	Minor1	Major1	Major2		
Conflicting Flow All	1219	759	0	0	761
Stage 1	759	-	-	-	-
Stage 2	460	-	-	-	-
Critical Hdwy	6.4	6.45	-	-	4.1
Critical Hdwy Stg 1	5.4	-	-	-	-
Critical Hdwy Stg 2	5.4	-	-	-	-
Follow-up Hdwy	3.5	3.525	-	-	2.2
Pot Cap-1 Maneuver	201	372	-	-	860
Stage 1	466	-	-	-	-
Stage 2	640	-	-	-	-
Platoon blocked, %			-	-	-
Mov Cap-1 Maneuver	200	372	-	-	860
Mov Cap-2 Maneuver	200	-	-	-	-
Stage 1	466	-	-	-	-
Stage 2	637	-	-	-	-

Approach	WB	NB	SB
HCM Control Delay, s	18.5	0	0.1
HCM LOS	C		

Minor Lane/Major Mvmt	NBT	NBRWBLn1	SBL	SBT
Capacity (veh/h)	-	-	280	860
HCM Lane V/C Ratio	-	-	0.05	0.004
HCM Control Delay (s)	-	-	18.5	9.2
HCM Lane LOS	-	-	C	A
HCM 95th %tile Q(veh)	-	-	0.2	0

HCM Unsignalized Intersection Capacity Analysis
 102: N Main St & W Pinehurst Ct/E Pinehurst Dr

Existing Peak Hour Midday
 Existing SAT 2023

												
Movement	EBL	EBT	EBR	WBL	WBT	WBR	NBL	NBT	NBR	SBL	SBT	SBR
Lane Configurations												
Traffic Volume (veh/h)	2	3	0	23	5	4	0	109	17	0	77	1
Future Volume (Veh/h)	2	3	0	23	5	4	0	109	17	0	77	1
Sign Control		Stop			Stop			Free			Free	
Grade		0%			0%			0%			0%	
Peak Hour Factor	0.55	0.55	0.55	0.55	0.55	0.55	0.55	0.55	0.55	0.55	0.55	0.55
Hourly flow rate (vph)	4	5	0	42	9	7	0	198	31	0	140	2
Pedestrians		7			12			1				
Lane Width (ft)		12.0			12.0			12.0				
Walking Speed (ft/s)		3.5			3.5			3.5				
Percent Blockage		1			1			0				
Right turn flare (veh)												
Median type								None			None	
Median storage (veh)												
Upstream signal (ft)												
pX, platoon unblocked												
vC, conflicting volume	373	389	149	370	374	226	149			241		
vC1, stage 1 conf vol												
vC2, stage 2 conf vol												
vCu, unblocked vol	373	389	149	370	374	226	149			241		
tC, single (s)	7.1	6.5	6.2	7.1	6.5	6.2	4.1			4.1		
tC, 2 stage (s)												
tF (s)	3.5	4.0	3.3	3.5	4.0	3.3	2.2			2.2		
p0 queue free %	99	99	100	93	98	99	100			100		
cM capacity (veh/h)	564	539	896	571	549	810	1435			1322		
Direction, Lane #	EB 1	WB 1	NB 1	SB 1								
Volume Total	9	58	229	142								
Volume Left	4	42	0	0								
Volume Right	0	7	31	2								
cSH	550	588	1435	1322								
Volume to Capacity	0.02	0.10	0.00	0.00								
Queue Length 95th (ft)	1	8	0	0								
Control Delay (s)	11.7	11.8	0.0	0.0								
Lane LOS	B	B										
Approach Delay (s)	11.7	11.8	0.0	0.0								
Approach LOS	B	B										
Intersection Summary												
Average Delay			1.8									
Intersection Capacity Utilization			19.4%		ICU Level of Service				A			
Analysis Period (min)			15									

Intersection												
Int Delay, s/veh	1.8											
Movement	EBL	EBT	EBR	WBL	WBT	WBR	NBL	NBT	NBR	SBL	SBT	SBR
Lane Configurations		↕			↕			↕			↕	
Traffic Vol, veh/h	2	3	0	23	5	4	0	109	17	0	77	1
Future Vol, veh/h	2	3	0	23	5	4	0	109	17	0	77	1
Conflicting Peds, #/hr	0	0	1	1	0	0	7	0	12	12	0	7
Sign Control	Stop	Stop	Stop	Stop	Stop	Stop	Free	Free	Free	Free	Free	Free
RT Channelized	-	-	None	-	-	None	-	-	None	-	-	None
Storage Length	-	-	-	-	-	-	-	-	-	-	-	-
Veh in Median Storage, #	-	0	-	-	0	-	-	0	-	-	0	-
Grade, %	-	0	-	-	0	-	-	0	-	-	0	-
Peak Hour Factor	55	55	55	55	55	55	55	55	55	55	55	55
Heavy Vehicles, %	0	0	0	0	0	0	0	1	6	0	3	0
Mvmt Flow	4	5	0	42	9	7	0	198	31	0	140	2

















Major/Minor	Minor2		Minor1		Major1		Major2					
Conflicting Flow All	370	389	149	371	375	226	149	0	0	241	0	0
Stage 1	148	148	-	226	226	-	-	-	-	-	-	-
Stage 2	222	241	-	145	149	-	-	-	-	-	-	-
Critical Hdwy	7.1	6.5	6.2	7.1	6.5	6.2	4.1	-	-	4.1	-	-
Critical Hdwy Stg 1	6.1	5.5	-	6.1	5.5	-	-	-	-	-	-	-
Critical Hdwy Stg 2	6.1	5.5	-	6.1	5.5	-	-	-	-	-	-	-
Follow-up Hdwy	3.5	4	3.3	3.5	4	3.3	2.2	-	-	2.2	-	-
Pot Cap-1 Maneuver	590	549	903	589	559	818	1445	-	-	1337	-	-
Stage 1	859	779	-	781	721	-	-	-	-	-	-	-
Stage 2	785	710	-	863	778	-	-	-	-	-	-	-
Platoon blocked, %								-	-	-	-	-
Mov Cap-1 Maneuver	573	539	896	577	549	809	1435	-	-	1322	-	-
Mov Cap-2 Maneuver	573	539	-	577	549	-	-	-	-	-	-	-
Stage 1	853	774	-	772	713	-	-	-	-	-	-	-
Stage 2	768	702	-	856	773	-	-	-	-	-	-	-

Approach	EB		WB		NB		SB	
HCM Control Delay, s	11.6		11.7		0		0	
HCM LOS	B		B					

Minor Lane/Major Mvmt	NBL	NBT	NBR	EBLn1WBLn1	SBL	SBT	SBR
Capacity (veh/h)	1435	-	-	552	594	1322	-
HCM Lane V/C Ratio	-	-	-	0.016	0.098	-	-
HCM Control Delay (s)	0	-	-	11.6	11.7	0	-
HCM Lane LOS	A	-	-	B	B	A	-
HCM 95th %tile Q(veh)	0	-	-	0.1	0.3	0	-

HCM Unsignalized Intersection Capacity Analysis
 103: N College St (Hwy 219) & E Pinehurst Dr

Existing Peak Hour Midday
 Existing SAT 2023

												
Movement	EBL	EBT	EBR	WBL	WBT	WBR	NBL	NBT	NBR	SBL	SBT	SBR
Lane Configurations												
Traffic Volume (veh/h)	10	7	11	5	2	8	4	262	8	6	328	7
Future Volume (Veh/h)	10	7	11	5	2	8	4	262	8	6	328	7
Sign Control		Stop			Stop			Free			Free	
Grade		0%			0%			0%			0%	
Peak Hour Factor	0.91	0.91	0.91	0.91	0.91	0.91	0.91	0.91	0.91	0.91	0.91	0.91
Hourly flow rate (vph)	11	8	12	5	2	9	4	288	9	7	360	8
Pedestrians		1										
Lane Width (ft)		12.0										
Walking Speed (ft/s)		3.5										
Percent Blockage		0										
Right turn flare (veh)												
Median type								None			None	
Median storage (veh)												
Upstream signal (ft)												
pX, platoon unblocked												
vC, conflicting volume	690	684	365	694	684	292	369			297		
vC1, stage 1 conf vol												
vC2, stage 2 conf vol												
vCu, unblocked vol	690	684	365	694	684	292	369			297		
tC, single (s)	7.1	6.5	6.2	7.1	6.5	6.2	4.1			4.1		
tC, 2 stage (s)												
tF (s)	3.5	4.0	3.3	3.5	4.0	3.3	2.2			2.2		
p0 queue free %	97	98	98	99	99	99	100			99		
cM capacity (veh/h)	354	370	684	345	370	752	1200			1276		
Direction, Lane #	EB 1	WB 1	NB 1	SB 1								
Volume Total	31	16	301	375								
Volume Left	11	5	4	7								
Volume Right	12	9	9	8								
cSH	441	502	1200	1276								
Volume to Capacity	0.07	0.03	0.00	0.01								
Queue Length 95th (ft)	6	2	0	0								
Control Delay (s)	13.8	12.4	0.1	0.2								
Lane LOS	B	B	A	A								
Approach Delay (s)	13.8	12.4	0.1	0.2								
Approach LOS	B	B										
Intersection Summary												
Average Delay			1.0									
Intersection Capacity Utilization			31.1%		ICU Level of Service				A			
Analysis Period (min)			15									

Intersection												
Int Delay, s/veh	1											
Movement	EBL	EBT	EBR	WBL	WBT	WBR	NBL	NBT	NBR	SBL	SBT	SBR
Lane Configurations		↕			↕			↕			↕	
Traffic Vol, veh/h	10	7	11	5	2	8	4	262	8	6	328	7
Future Vol, veh/h	10	7	11	5	2	8	4	262	8	6	328	7
Conflicting Peds, #/hr	0	0	0	0	0	0	1	0	0	0	0	1
Sign Control	Stop	Stop	Stop	Stop	Stop	Stop	Free	Free	Free	Free	Free	Free
RT Channelized	-	-	None	-	-	None	-	-	None	-	-	None
Storage Length	-	-	-	-	-	-	-	-	-	-	-	-
Veh in Median Storage, #	-	0	-	-	0	-	-	0	-	-	0	-
Grade, %	-	0	-	-	0	-	-	0	-	-	0	-
Peak Hour Factor	91	91	91	91	91	91	91	91	91	91	91	91
Heavy Vehicles, %	0	0	0	0	0	0	0	1	0	0	1	0
Mvmt Flow	11	8	12	5	2	9	4	288	9	7	360	8

Major/Minor	Minor2		Minor1		Major1		Major2					
Conflicting Flow All	685	684	365	689	684	293	369	0	0	297	0	0
Stage 1	379	379	-	301	301	-	-	-	-	-	-	-
Stage 2	306	305	-	388	383	-	-	-	-	-	-	-
Critical Hdwy	7.1	6.5	6.2	7.1	6.5	6.2	4.1	-	-	4.1	-	-
Critical Hdwy Stg 1	6.1	5.5	-	6.1	5.5	-	-	-	-	-	-	-
Critical Hdwy Stg 2	6.1	5.5	-	6.1	5.5	-	-	-	-	-	-	-
Follow-up Hdwy	3.5	4	3.3	3.5	4	3.3	2.2	-	-	2.2	-	-
Pot Cap-1 Maneuver	365	374	685	363	374	751	1201	-	-	1276	-	-
Stage 1	647	618	-	712	669	-	-	-	-	-	-	-
Stage 2	708	666	-	640	616	-	-	-	-	-	-	-
Platoon blocked, %								-	-	-	-	-
Mov Cap-1 Maneuver	356	370	684	348	370	751	1200	-	-	1276	-	-
Mov Cap-2 Maneuver	356	370	-	348	370	-	-	-	-	-	-	-
Stage 1	644	613	-	709	666	-	-	-	-	-	-	-
Stage 2	695	663	-	616	611	-	-	-	-	-	-	-

Approach	EB		WB		NB		SB	
HCM Control Delay, s	13.7		12.6		0.1		0.1	
HCM LOS	B		B					

Minor Lane/Major Mvmt	NBL	NBT	NBR	EBLn1WBLn1	SBL	SBT	SBR
Capacity (veh/h)	1200	-	-	444	493	1276	-
HCM Lane V/C Ratio	0.004	-	-	0.069	0.033	0.005	-
HCM Control Delay (s)	8	0	-	13.7	12.6	7.8	0
HCM Lane LOS	A	A	-	B	B	A	A
HCM 95th %tile Q(veh)	0	-	-	0.2	0.1	0	-

Intersection						
Int Delay, s/veh	5.6					
Movement	SEL	SET	NWT	NWR	SWL	SWR
Lane Configurations						
Traffic Vol, veh/h	50	405	358	110	119	56
Future Vol, veh/h	50	405	358	110	119	56
Conflicting Peds, #/hr	2	0	0	2	0	0
Sign Control	Free	Free	Free	Free	Stop	Stop
RT Channelized	-	None	-	None	-	None
Storage Length	75	-	-	-	0	-
Veh in Median Storage, #	-	0	0	-	0	-
Grade, %	-	0	0	-	0	-
Peak Hour Factor	92	92	92	92	92	92
Heavy Vehicles, %	0	3	4	1	1	2
Mvmt Flow	54	440	389	120	129	61

Major/Minor	Major1	Major2	Minor2		
Conflicting Flow All	511	0	-	0	999 451
Stage 1	-	-	-	-	451 -
Stage 2	-	-	-	-	548 -
Critical Hdwy	4.1	-	-	-	6.41 6.22
Critical Hdwy Stg 1	-	-	-	-	5.41 -
Critical Hdwy Stg 2	-	-	-	-	5.41 -
Follow-up Hdwy	2.2	-	-	-	3.509 3.318
Pot Cap-1 Maneuver	1065	-	-	-	271 608
Stage 1	-	-	-	-	644 -
Stage 2	-	-	-	-	581 -
Platoon blocked, %		-	-	-	
Mov Cap-1 Maneuver	1063	-	-	-	256 607
Mov Cap-2 Maneuver	-	-	-	-	256 -
Stage 1	-	-	-	-	610 -
Stage 2	-	-	-	-	580 -

Approach	SE	NW	SW
HCM Control Delay, s	0.9	0	32.6
HCM LOS			D

Minor Lane/Major Mvmt	NWT	NWR	SEL	SETSWLn1
Capacity (veh/h)	-	-	1063	- 314
HCM Lane V/C Ratio	-	-	0.051	- 0.606
HCM Control Delay (s)	-	-	8.6	- 32.6
HCM Lane LOS	-	-	A	- D
HCM 95th %tile Q(veh)	-	-	0.2	- 3.7

HCM Unsignalized Intersection Capacity Analysis
 105: E Illinois St & N Main St

Existing Peak Hour Midday
 Existing SAT 2023



Movement	EBL	EBR	NBL	NBT	SBT	SBR
Lane Configurations						
Traffic Volume (veh/h)	106	58	56	20	33	146
Future Volume (Veh/h)	106	58	56	20	33	146
Sign Control	Free			Stop	Stop	
Grade	0%			0%	0%	
Peak Hour Factor	0.77	0.77	0.77	0.77	0.77	0.77
Hourly flow rate (vph)	138	75	73	26	43	190
Pedestrians						
Lane Width (ft)						
Walking Speed (ft/s)						
Percent Blockage						
Right turn flare (veh)						
Median type	None					
Median storage (veh)						
Upstream signal (ft)						
pX, platoon unblocked						
vC, conflicting volume	0		525	314	351	0
vC1, stage 1 conf vol						
vC2, stage 2 conf vol						
vCu, unblocked vol	0		525	314	351	0
tC, single (s)	4.1		7.1	6.5	6.5	6.2
tC, 2 stage (s)						
tF (s)	2.2		3.5	4.0	4.0	3.3
p0 queue free %	92		78	95	92	83
cM capacity (veh/h)	1636		338	547	528	1091
Direction, Lane #	EB 1	NB 1	SB 1			
Volume Total	213	99	233			
Volume Left	138	73	0			
Volume Right	75	0	190			
cSH	1636	376	912			
Volume to Capacity	0.08	0.26	0.26			
Queue Length 95th (ft)	7	26	25			
Control Delay (s)	5.0	18.0	10.3			
Lane LOS	A	C	B			
Approach Delay (s)	5.0	18.0	10.3			
Approach LOS		C	B			
Intersection Summary						
Average Delay			9.6			
Intersection Capacity Utilization			34.3%	ICU Level of Service	A	
Analysis Period (min)			15			